

# INSTRUCTION MANUAL

# TECO INVERTER

**200V Class 0.4~15KW  
(0.5~20HP)**

**400V Class 0.75~18.5KW  
(1~25HP)**



**TECO INVERTER**  
**E510 Series**

# Table of Contents

<b>Preface</b>		0-1
<b>Chapter 1</b>	<b>Safety Precautions</b>	1-1
1.1	Before Power UP	1-1
1.2	During Power UP	1-2
1.3	Before Operation	1-2
1.4	During Operation	1-2
1.5	Inverter Disposal	1-3
<b>Chapter 2</b>	<b>Model Description</b>	2-1
2.1	Nameplate Data	2-1
2.2	Model Identification	2-1
2.3	Standard Product Specification	2-2
<b>Chapter 3</b>	<b>Environment &amp; Installation</b>	3-1
3.1	Environment	3-1
3.2	Installation	3-3
	3.2.1 Installation method	3-3
	3.2.2 Installation space	3-20
	3.2.3 De-rating curves	3-21
3.3	Wiring guidelines	3-22
	3.3.1 Power Cables	3-22
	3.3.2 Control Cable selection and Wiring	3-22
	3.3.3 Wiring and EMC guidelines	3-23
	3.3.4 Failure liability	3-24
	3.3.5 Considerations for peripheral equipment	3-25
	3.3.6 Ground connection	3-26
	3.3.7 Inverter exterior	3-27
3.4	Specifications	3-35
	3.4.1 Product Specifications	3-35
	3.4.2 General Specifications	3-37
3.5	Standard wiring	3-39
	3.5.1 Single phase	3-39
	3.5.2 Single/ Three phase	3-40
	3.5.3 Three phase	3-41
3.6	Terminal Description	3-42
	3.6.1 Description of main circuit terminals	3-42
	3.6.2 Control circuit terminal description	3-44
3.7	Outline Dimensions	3-46
	3.7.1 IP20/NEMA1 dimensions	3-46
	3.7.2 IP66/NEMA4X dimensions	3-55
3.8	EMC filter disconnection	3-58
3.9	The Dimension and Installation of Operator panel	3-59
	3.9.1 Description of dimension and installation	3-59

	3.9.2 Description of Protective Cover	3-61
<b>Chapter 4</b>	<b>Software Index</b>	4-1
4.1	Keypad Description	4-1
	4.1.1 Operator Panel Functions	4-1
	4.1.2 Digital display Description	4-2
	4.1.3 Digital display setup	4-4
	4.1.4 Example of Keypad Operation	4-5
	4.1.5 Operation Control	4-7
4.2	Programmable Parameter Groups	4-8
4.3	Parameter Function Description	4-28
4.4	Specification Description on Built-in PLC Function	4-81
	4.4.1 Basic Instruction Set	4-81
	4.4.2 Function of Basic Instructions	4-82
	4.4.3 Application Instructions	4-83
<b>Chapter 5</b>	<b>Troubleshooting and Maintenance</b>	5-1
5.1	Error Display and Corrective Action	5-1
	5.1.1 Manual Reset and Auto-Reset	5-1
	5.1.2 Keypad Operation Error Instruction	5-3
	5.1.3 Special conditions	5-4
5.2	General troubleshooting	5-5
5.3	Troubleshooting of the Inverter	5-5
5.4	Routine and periodic inspection	5-6
5.5	Maintenance	5-7
<b>Chapter 6</b>	<b>Peripheral Components</b>	6-1
6.1	Reactor Specifications	6-1
6.2	Electromagnetic Contactor circuit breaker	6-1
6.3	Fuse Specification	6-2
6.4	Fuse Specification(UL Model Recommended)	6-2
6.5	Brake Resistor	6-3
6.6	Noise filter	6-3
<b>Appendix 1</b>	Instructions for UL	App1-1
<b>Appendix 2</b>	E510 Parameter Setting List	App2-1
<b>Appendix 3</b>	E510 MODBUS Communication protocol	App3-1
<b>Appendix 4</b>	E510 PLC Communication protocol	App4-1
<b>Appendix 5</b>	JN5-CM-USB instruction manual	App5-1
<b>Appendix 6</b>	510 series accessories manual	App6-1

# Preface

To extend the performance of the product and ensure personnel safety, please read this manual thoroughly before using the inverter. Should there be any problem in using the product that cannot be solved with the information provided in the manual, contact Our's technical or sales representative who will be willing to help you.

## ※Precautions

The inverter is an electrical product. For your safety, there are symbols such as “Danger”, “Caution” in this manual as a reminder to pay attention to safety instructions on handling, installing, operating, and checking the inverter. Be sure to follow the instructions for highest safety.



Indicates a potential hazard that could cause death or serious personal injury if misused.



Indicates that the inverter or the mechanical system might be damaged if misused.



- Risk of electric shock. The DC link capacitors remain charged for five minutes after power has been removed. It is not permissible to open the equipment until 5 minutes after the power has been removed.
- Do not make any connections when the inverter is powered on. Do not check parts and signals on circuit boards during the inverter operation.
- Do not disassemble the inverter or modify any internal wires, circuits, or parts.
- Ensure that the Inverter Ground terminal is connected correctly.



- Do not perform a voltage test on parts inside the inverter. High voltage can destroy the semiconductor components.
- Do not connect T1, T2, and T3 terminals of the inverter to any AC input power supply.
- CMOS ICs on the inverter's main board are susceptible to static electricity. Do not touch the main circuit board.



# Chapter 1 Safety Precautions

## 1.1 Before Power Up



### Danger

- Make sure the main circuit connections are correct Single phase L1(L),L3(N), Three phase L1(L),L2,L3(N) are power-input terminals and must not be mistaken for T1,T2 and T3. Otherwise, inverter damage can result.



### Caution

- The line voltage applied must comply with the inverter's specified input voltage.(See the nameplate)
- To avoid the front cover from disengaging, or other damage do not carry the inverter by its covers. Support the drive by the heat sink when transporting. Improper handling can damage the inverter or injure personnel and should be avoided.
- To avoid the risk of fire, do not install the inverter on a flammable object.Install on nonflammable objects such as metal.
- This product provides the 24V for internal use only, do not use as the power supply sources for other external components, such as sensors, electronic components ... etc., otherwise it will cause adverse situation.
- When disconnecting the remote keypad, turn the power off first to avoid any damage to the keypad or the inverter.



### Caution

- This product is sold subject to EN 61800-3 and EN 61800-5-1. In a domestic environment this product may cause radio interference in which case the user may be required to apply corrective measures.
- Motor over temperature protection is not provided.



### Caution

- Work on the device/system by unqualified personnel or failure to comply with warnings can result in severe personal injury or serious damage to material. Only suitably qualified personnel trained in the setup, installation, commissioning and operation of the product should carry out work on the device/system.
- Only permanently-wired input power connections are allowed.

## 1.2 During Power Up



### Danger

- When the momentary power loss is longer than 2 seconds, the inverter will not have sufficient stored power for its control circuit. Therefore, when the power is re-applied, the run operation of the inverter will be based on the setup of following parameters:
  - Run parameters. 00-02 or 00-03.
  - Direct run on power up. Parameter. 07-04 and the status of external run switch,

**Note-** the start operation will be regardless of the settings for parameters 07-00/07-01/07-02.

### Danger. Direct run on power up.

If direct run on power up is enabled and inverter is set to external run with the run FWD/REV switch closed then the inverter will restart.

### Danger

Prior to use, ensure that all risks and safety implications are considered.

- When the momentary power loss ride through is selected and the power loss is short, the inverter will have sufficient stored power for its control circuits to function, therefore, when the power is resumed the inverter will automatically restart depending on the setup of parameters 07-00 & 7-01.

## 1.3 Before Operation



### Caution

- Make sure the inverter model and rating are the same as that set in parameter 13-00.

**Note** :On power up the supply voltage set in parameter 01-01 will flash on the display for 2 seconds.

## 1.4 During Operation



### Danger

- Do not connect or disconnect the motor during operation. Otherwise, It may cause the inverter to trip or damage the unit.



### Danger

- To avoid electric shock, do not take the front cover off while power is on.
- The motor will restart automatically after stop when auto-restart function is enabled. In this case, care must be taken while working around the drive and associated equipment .
- The operation of the stop switch is different than that of the emergency stop switch. The stop switch has to be activated to be effective. Emergency stop has to be de-activated to become effective.



### Caution

- Do not touch heat radiating components such as heat sinks and brake resistors. 
- The inverter can drive the motor from low speed to high speed. Verify the allowable speed ranges of the motor and the associated machinery.
- Risk of electric shock. The DC link capacitors remain charged for five minutes after power has been removed. It is not permissible to open the equipment until 5 minutes after the power has been removed.



### Caution

- The Inverter should be used in environments with temperature range from (14-104°F) or (-10 to 50°C)\* and relative humidity of 95%.

\* IP20 : -10 ~ 50 °C without stick on type dust cover.  
NEMA1 : -10 ~ 40 °C with stick on type dust cover.



### Danger

- Make sure that the power is switched off before disassembling or checking any components.

## 1.5 Inverter Disposal



### Caution

- Please dispose of this unit with care as an industrial waste and according to your required local regulations.
- The capacitors of inverter main circuit and printed circuit board are considered as hazardous waste and must not be burnt.
  - The plastic enclosure and parts of the inverter such as the cover board will release harmful gases if burnt.

# Chapter 2 Model Description

## 2.1 Nameplate Data

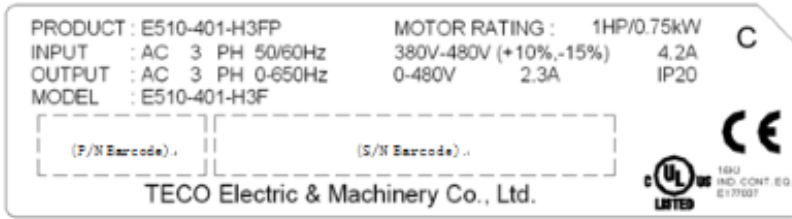

- ← Product Name and Motor Rating
- ← Input Power Specifications
- ← Output Power Specifications

## 2.2 Model Identification

E510 - 2 P5 - H 1 F N4S

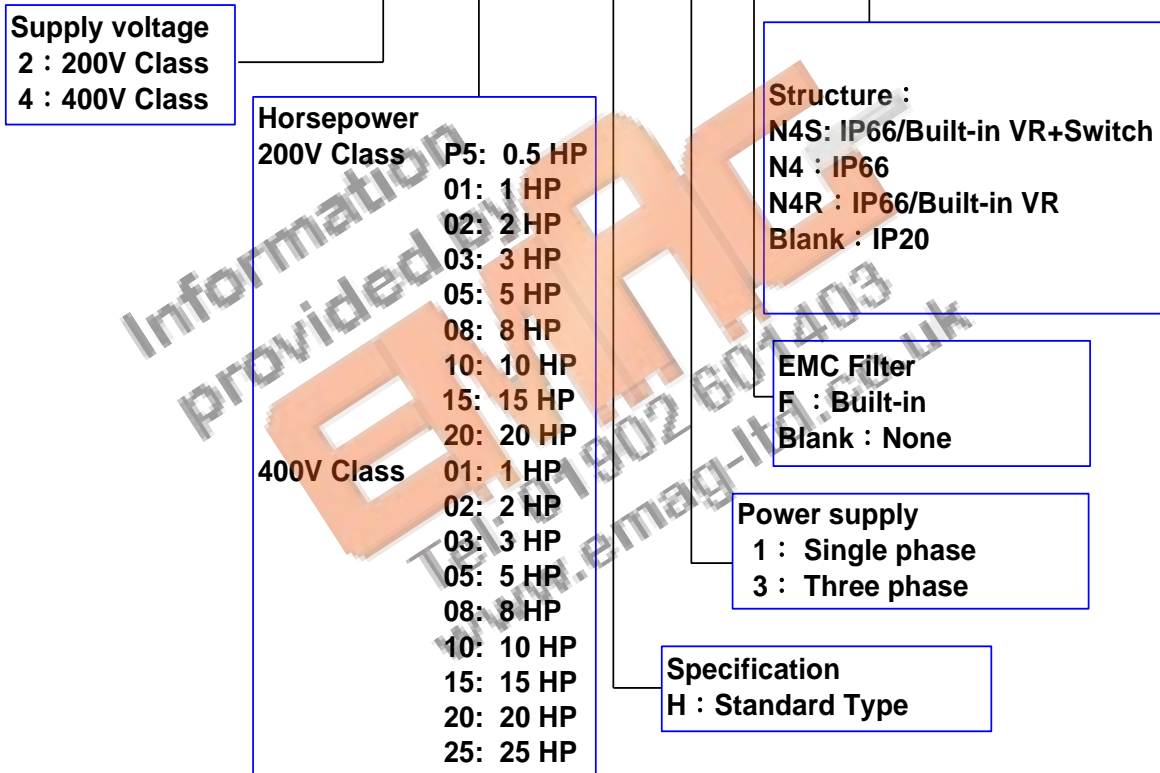

## 2.3 Standard Product Specification

### IP20 / NEMA 1 Type

Model	Supply voltage (Vac)	(HP)	(KW)	Filter		Frame Size
				V	X	
E510-2P5-H1F	1 ph, 200~240V (+10%-15%) 50/60 Hz	0.5	0.4	⊙		1
E510-201-H1F		1	0.75	⊙		1
E510-202-H1F		2	1.5	⊙		2
E510-203-H1F		3	2.2	⊙		2
E510-2P5-H	1 & 3 ph, 200~240V (+10%-15%) 50/60 Hz	0.5	0.4		⊙	1
E510-201-H		1	0.75		⊙	1
E510-202-H		2	1.5		⊙	2
E510-203-H		3	2.2		⊙	2
E510-202-H3	3ph, 200~240V (+10%-15%) 50/60 Hz	2	1.5		⊙	1
E510-205-H3		5	3.7		⊙	2
E510-208-H3		7.5	5.5		⊙	3
E510-210-H3		10	7.5		⊙	3
E510-215-H3		15	11		⊙	4
E510-220-H3		20	15		⊙	4
E510-401-H3F		3ph, 380~480V (+10%-15%) 50/60 Hz	1	0.75	⊙	
E510-401-H3	1		0.75		⊙	1
E510-402-H3F	2		1.5	⊙		1
E510-402-H3	2		1.5		⊙	1
E510-403-H3F	3		2.2	⊙		2
E510-403-H3	3		2.2		⊙	2
E510-405-H3F	5		3.7	⊙		2
E510-405-H3	5		3.7		⊙	2
E510-408-H3F	7.5		5.5	⊙		3
E510-408-H3	7.5		5.5		⊙	3
E510-410-H3F	10		7.5	⊙		3
E510-410-H3	10		7.5		⊙	3
E510-415-H3F	15		11	⊙		3
E510-415-H3	15		11		⊙	3
E510-420-H3F	20		15	⊙		4
E510-420-H3	20		15		⊙	4
E510-425-H3F	25		18.5	⊙		4
E510-425-H3	25		18.5		⊙	4

**V : Built-in**

**X : None**



**IP66 / NEMA 4X Type**

Model	Supply voltage (Vac)	HP	(KW)	Filter		VR		Switch		Frame Size
				V	X	V	X	V	X	
E510-2P5-H1FN4S	1 ph 200~240V +10%-15% 50/60Hz	0.5	0.4	⊙		⊙		⊙		1
E510-201-H1FN4S		1	0.75	⊙		⊙		⊙		1
E510-202-H1FN4S		2	1.5	⊙		⊙		⊙		2
E510-203-H1FN4S		3	2.2	⊙		⊙		⊙		2
E510-2P5-HN4R	1 & 3 ph 200~240V +10%-15% 50/60Hz	0.5	0.4		⊙	⊙			⊙	1
E510-201-HN4R		1	0.75		⊙	⊙			⊙	1
E510-202-HN4R		2	1.5		⊙	⊙			⊙	2
E510-203-HN4R		3	2.2		⊙	⊙			⊙	2
E510-205-H3N4	3 ph 200~240V +10%-15% 50/60Hz	5	3.7		⊙		⊙		⊙	2
E510-208-H3N4		7.5	5.5		⊙		⊙		⊙	3
E510-210-H3N4		10	7.5		⊙		⊙		⊙	3
E510-215-H3N4		15	11		⊙		⊙		⊙	3
E510-220-H3N4		20	15		⊙		⊙		⊙	3
E510-401-H3FN4S	3 ph 380~480V +10%-15% 50/60Hz	1	0.75	⊙		⊙		⊙		1
E510-401-H3N4		1	0.75		⊙		⊙		⊙	1
E510-402-H3FN4S		2	1.5	⊙		⊙		⊙		1
E510-402-H3N4		2	1.5		⊙		⊙		⊙	1
E510-403-H3FN4S		3	2.2	⊙		⊙		⊙		2
E510-403-H3N4		3	2.2		⊙		⊙		⊙	2
E510-405-H3FN4S		5	3.7	⊙		⊙		⊙		2
E510-405-H3N4		5	3.7		⊙		⊙		⊙	2
E510-408-H3FN4S		7.5	5.5	⊙		⊙		⊙		3
E510-408-H3N4		7.5	5.5		⊙		⊙		⊙	3
E510-410-H3FN4S		10	7.5	⊙		⊙		⊙		3
E510-410-H3N4		10	7.5		⊙		⊙		⊙	3
E510-415-H3FN4S		15	11	⊙		⊙		⊙		3
E510-415-H3N4		15	11		⊙		⊙		⊙	3
E510-420-H3N4		20	15		⊙		⊙		⊙	3
E510-425-H3N4		25	18.5		⊙		⊙		⊙	3

**V : Built-in**

**X : None**

# Chapter 3 Environment & Installation

## 3.1 Environment

Installation environment has a direct effect on the correct operation and the life expectancy of the inverter, Install the inverter in an environment complying with the following conditions:

Protection	
Protection class	IP20 / NEMA 1 & IP66 / NEMA 4X (Depending on models)
Suitable Environment	
Operating temperature	IP20 / NEMA 1 type: -10 ~ 50°C inside distributor (without sticker on dust cover.), -10 ~ 40°C outside distributor (with sticker on dust cover.). IP66 / NEMA 4X type: -10~50°C If several inverters are installed in the same Operator panel, ensure adequate spacing and provide the necessary cooling and ventilation for successful operation.
Storage temperature	-20~60°C
Relative Humidity	Max 95% (without condensation) Notice prevention of inverter freezing up.(Compliance with IEC 60068-2-78).
Shock	1G. (9.8m/s <sup>2</sup> ) for 20Hz and below. 0.6G (5.88m/s <sup>2</sup> ) from 20Hz to 50Hz (Compliance with IEC 60068-2-6)

### Installation site

Install in an environment that will not have an adverse effect on the operation of the unit and ensure that there is no exposure to areas such as that listed below:-

- Direct sunlight, Rain or moisture.
- Oil mist and salt
- Dust, lint fibers, small metal filings and Corrosive liquid and gas.
- Electromagnetic interference from sources such as welding equipment.
- Radioactive and flammable materials.
- Excessive vibration from machines such as stamping, punching machines.  
add a vibration-proof pads if necessary.

### Tightening torque for terminals

Model	TM1					TM2				
	Cable Size		Tightening torque			Cable Size		Tightening torque		
	AWG	mm <sup>2</sup>	kgf.cm	lbf.in	Nm	AWG	mm <sup>2</sup>	kgf.cm	lbf.in	Nm
Frame1	20~12	0.52~3.33	10.20	0.006	1.0	26~14	0.13~2.08	8.16	0.005	0.8
Frame2	18~8	0.81~8.37	18.35	0.010	1.8					
Frame3	14~6	2.08~13.30	24.47	0.014	2.4					
Frame4	4~3	21.15~26.67								

**Electrical ratings of terminals**

Model	Horsepower	Power Specification	Voltage (Volt)	Current(A)
Frame1	0.5/1	200V~240V	600	20
	1/2	380V~480V		
Frame2	2/3/5	200V~240V	600	45
	3/5	380V~480V		
Frame 3/4	7.5/10/15/20	200V~240V	600	65
	7.5/10/15/20/25	380V~480V	600	100

**The maximum rms symmetrical short circuit ratings are as follows.**

Device Rating		Short circuit Rating(A)	Maximum Voltage (Volt)
voltage	HP		
220V	0.5~20	5000	240
440V	1~25	5000	480

Information provided by **EMAG**  
 Tel: 01902 601403  
[www.emag-ltd.co.uk](http://www.emag-ltd.co.uk)

## 3.2 Installation

### 3.2.1 Installation method

#### 3.2.1.1 IP20 / NEMA 1 standard installation

(a) Single/Three phase: 200V 0.5~1HP; Single phase: 200V 0.5~1HP; Three phase: 200V 2HP; 400V 1~2HP;

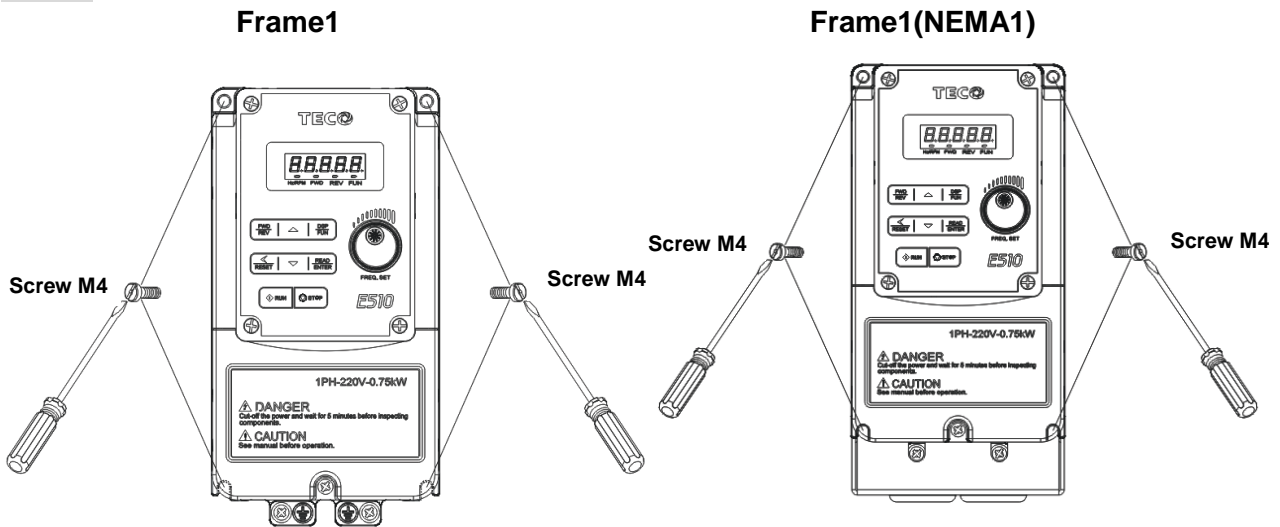

(b) Single/Three phase: 200V 2~3HP; Single phase: 200V 2~3HP; Three phase: 200V 5HP; 400V 3~5HP;

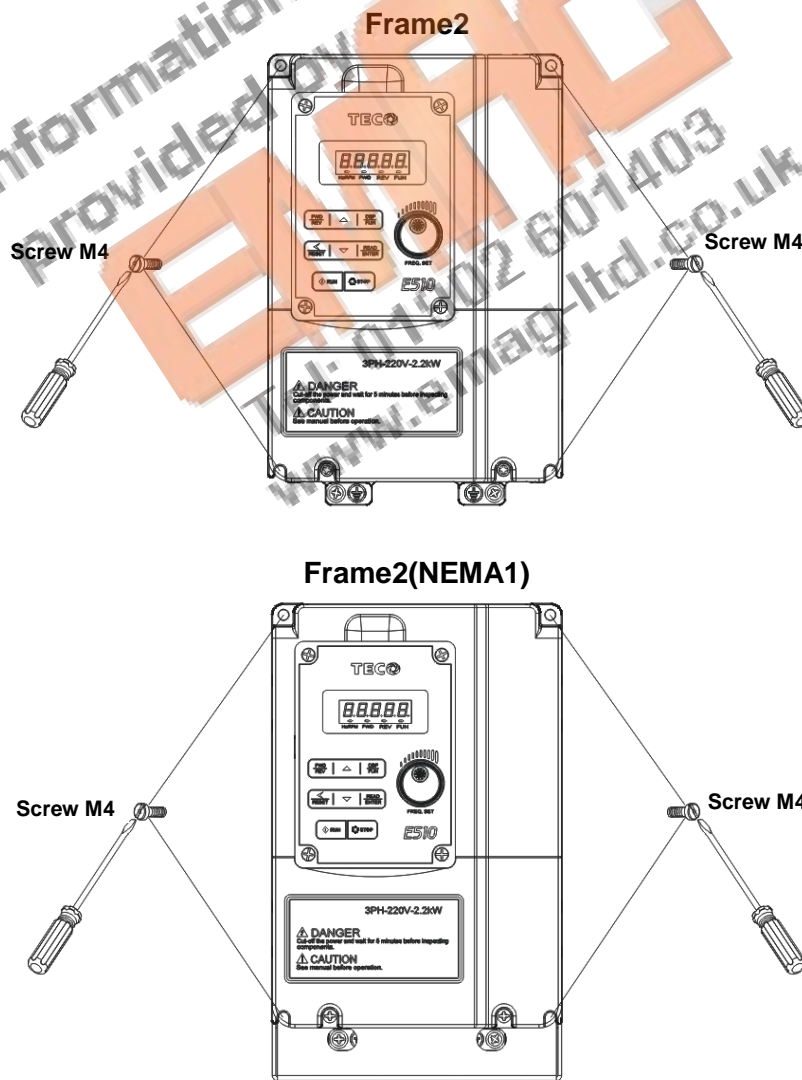

(c) Three phase: 200V 7.5~10HP; 400V 7.5~15HP;

### Frame3

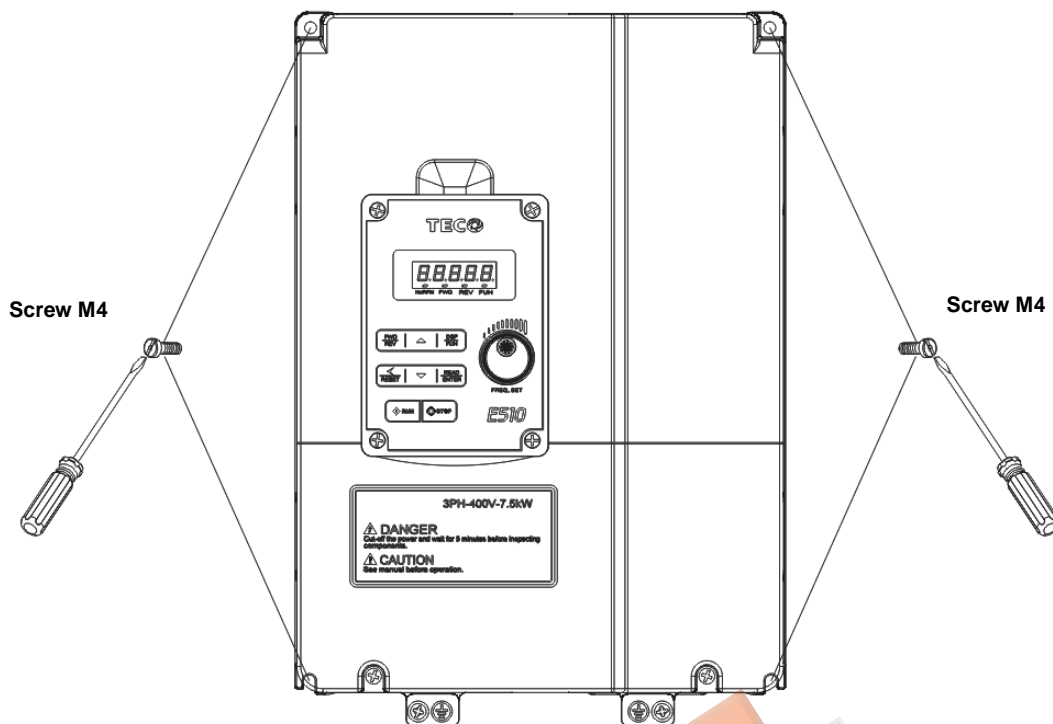

### Frame3(NEMA1)

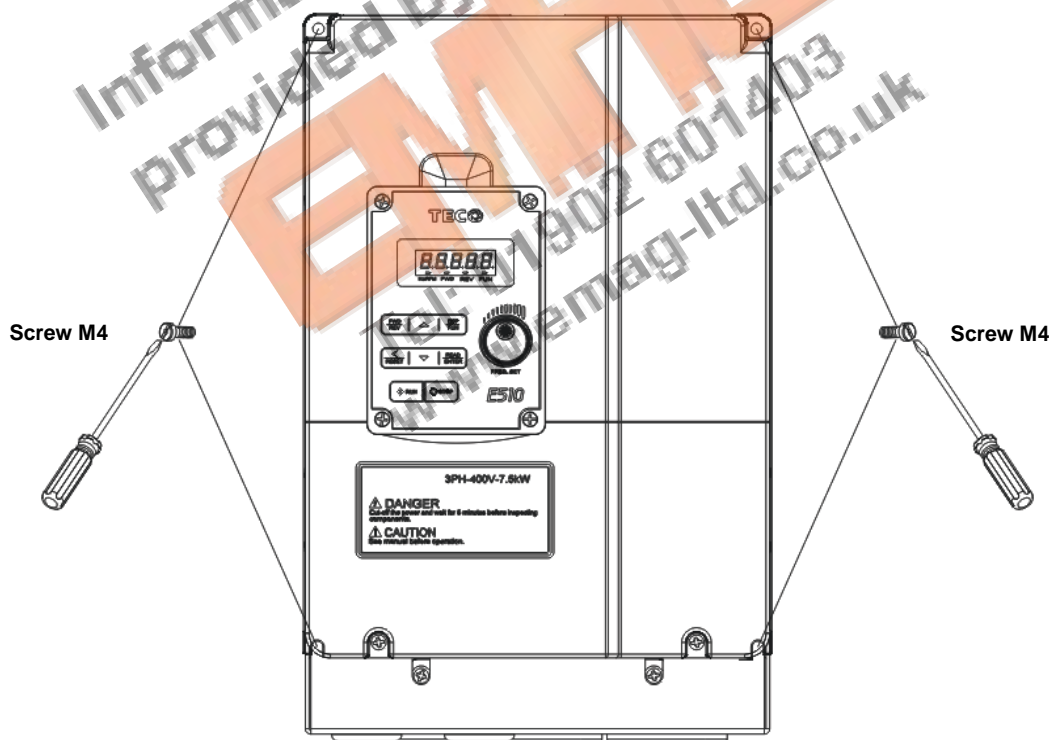



(d) Three phase: 200V 15~20HP; 400V 20~25HP;

### Frame4

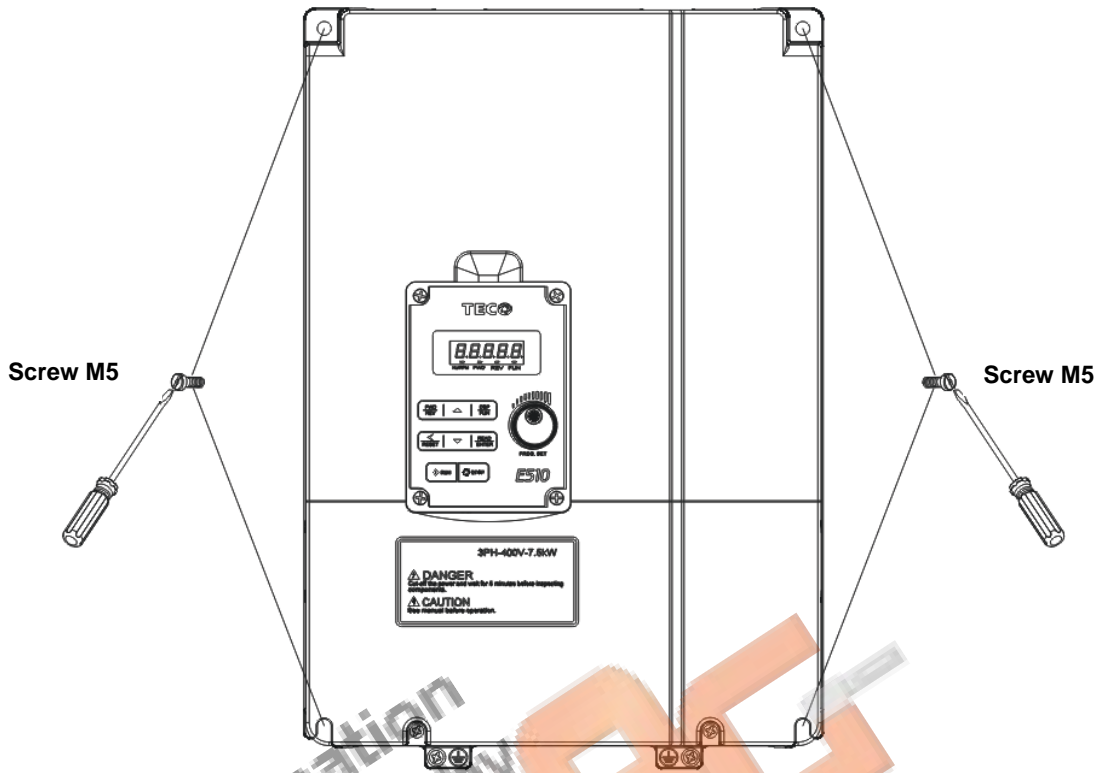

### Frame4(NEMA1)

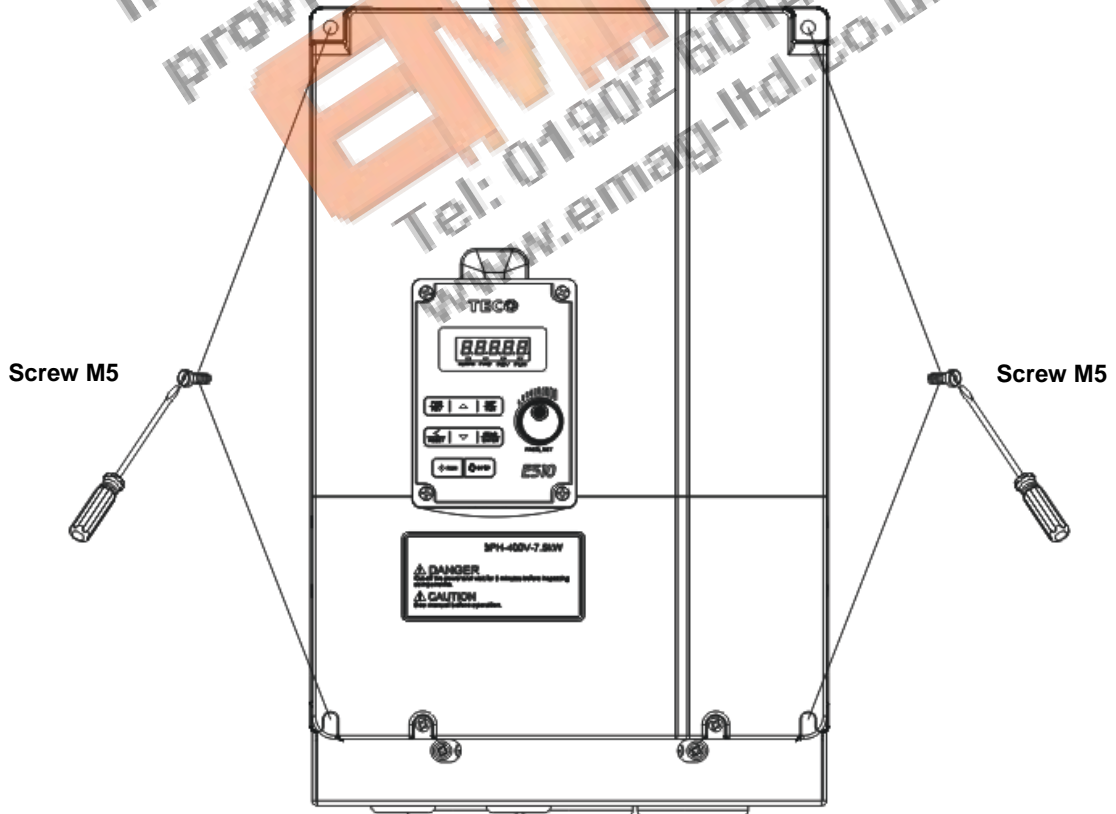

(e) Three phase: 400V 20~25HP; (With Fliter Models)

Frame4

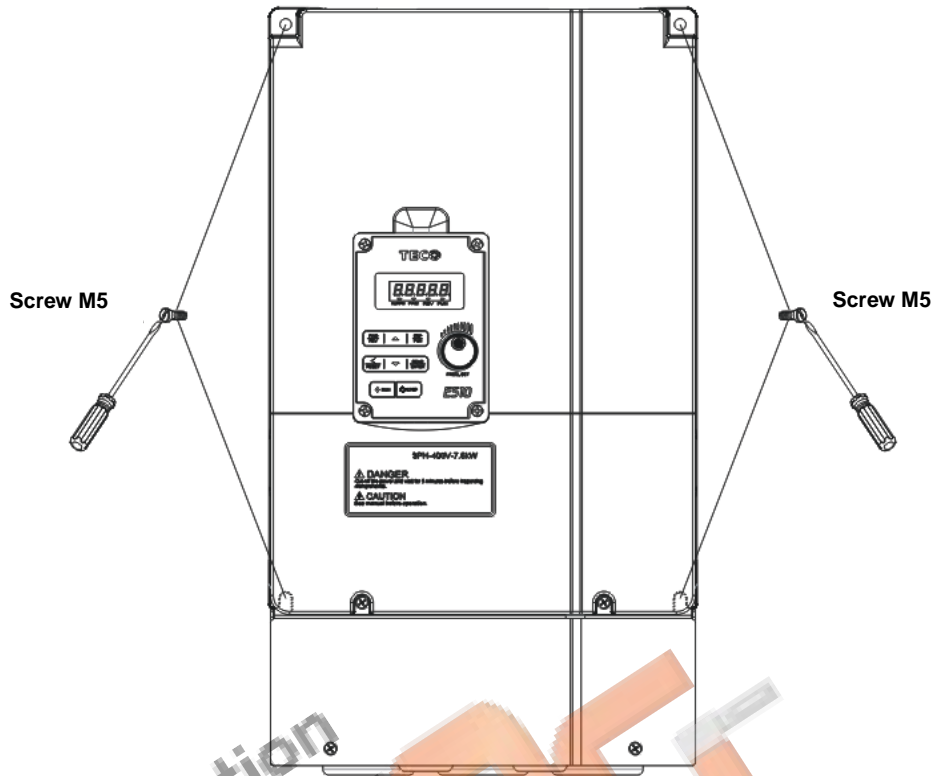

Information  
provided by  
**EMAG**  
Tel: 01902 601403  
www.emag-ltd.co.uk

### 3.2.1.2 IP66/NEMA 4X standard installation

(a) Single/Three phase : 200V 0.5~1HP ; Single phase : 200V 0.5~1HP ; Three phase : 200V 2HP ; 400V 1~2HP ;

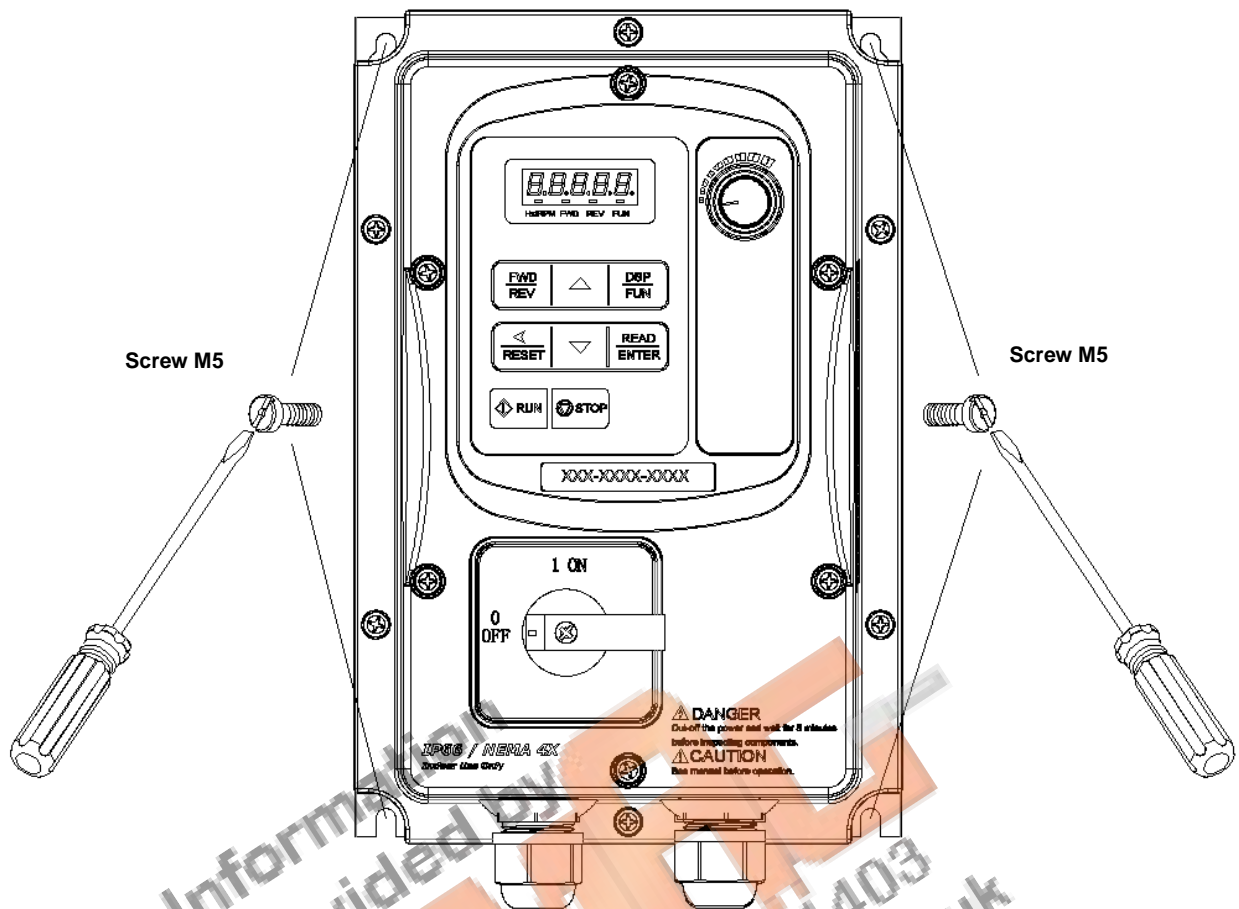

(b) Single / Three phase: 200V 2~3HP ; Single phase : 200V 2~3HP ; Three phase : 200V5HP ; 400V 3~5HP ;

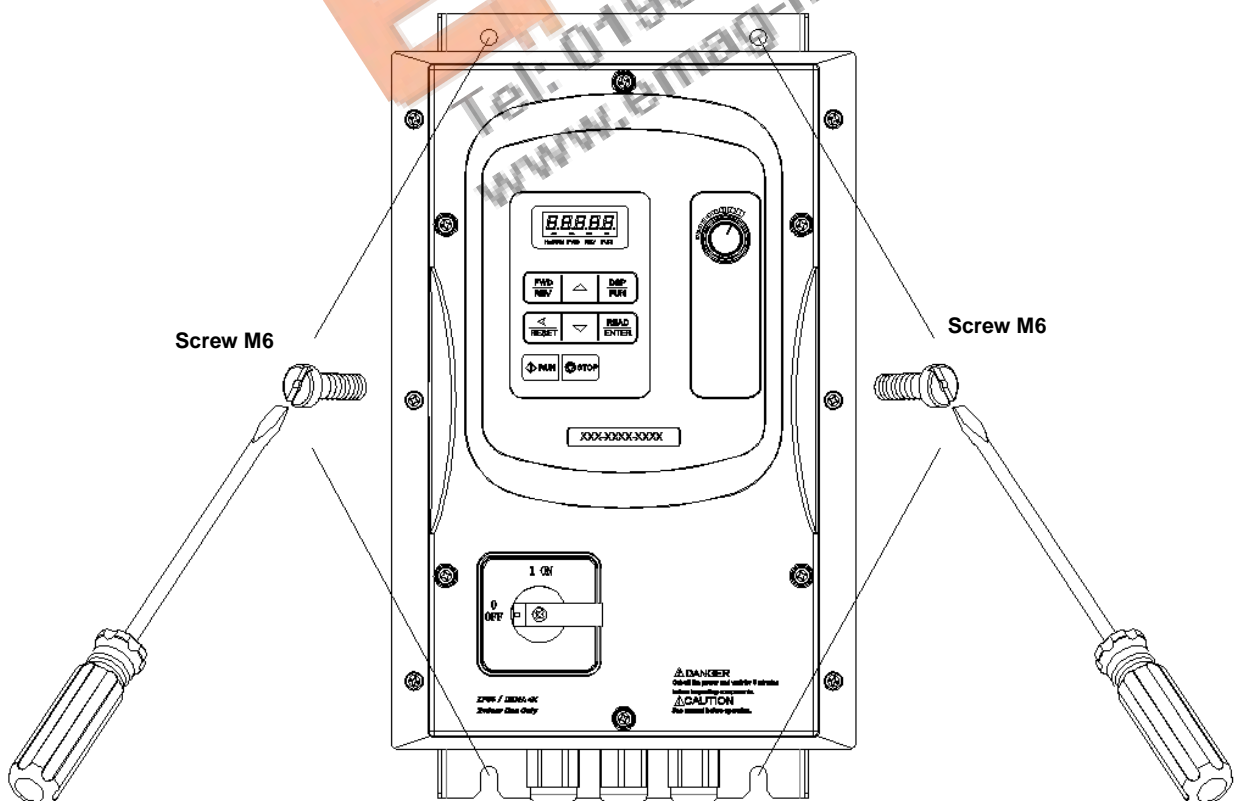

(c) Three phase : 200V 8~20HP ; 400V 8~25HP ;

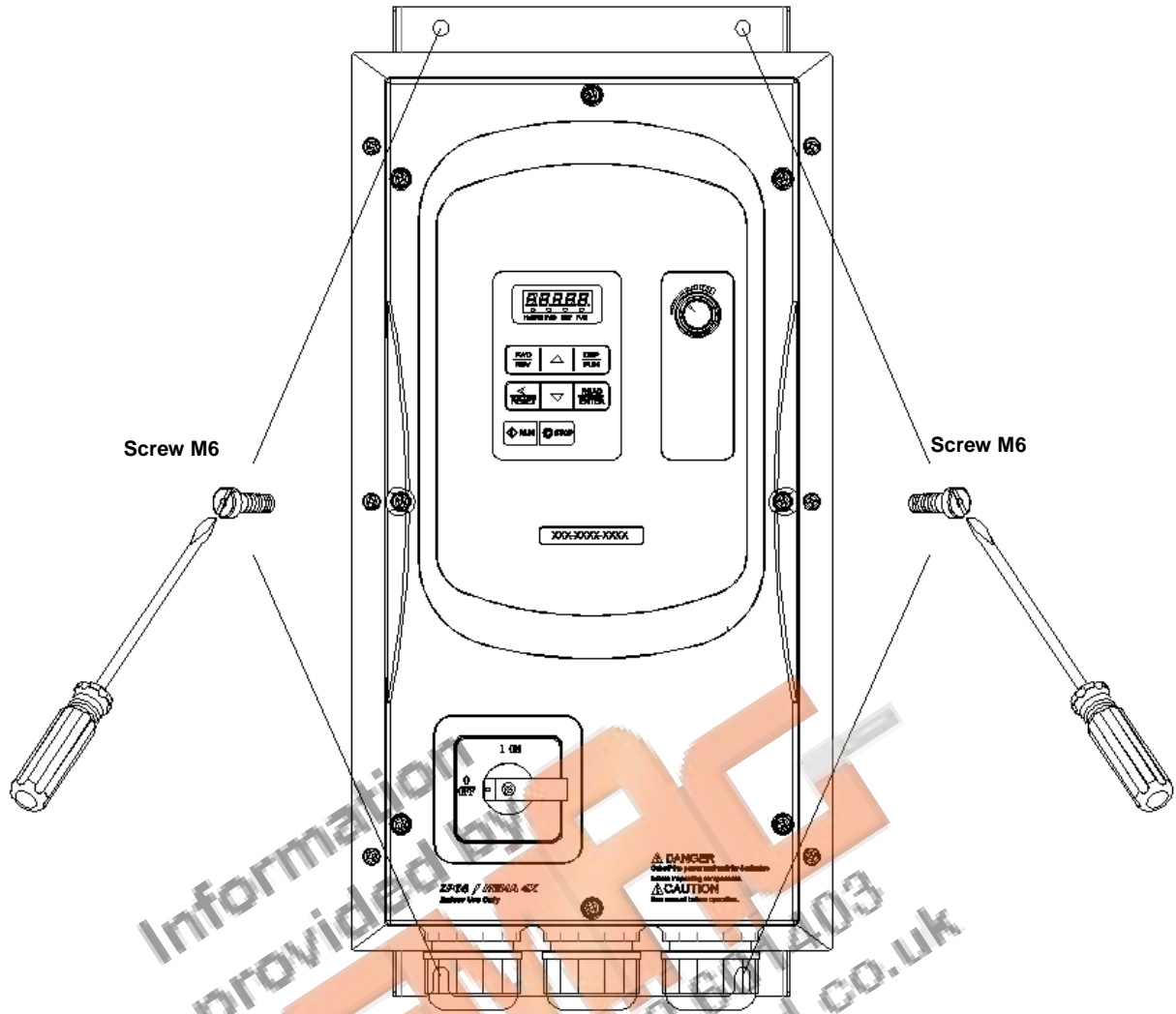

Information provided by  
EMAG LTD  
Tel: 01902 614403  
www.emag-ltd.co.uk

Disassembly and assembly steps, As follows:

➤ IP20 / NEMA 1

(a) Single/Three phase: 200V 0.5~1HP; Single phase: 200V 0.5~1HP; Three phase: 200V 2HP; 400V 1~2HP;  
Frame1

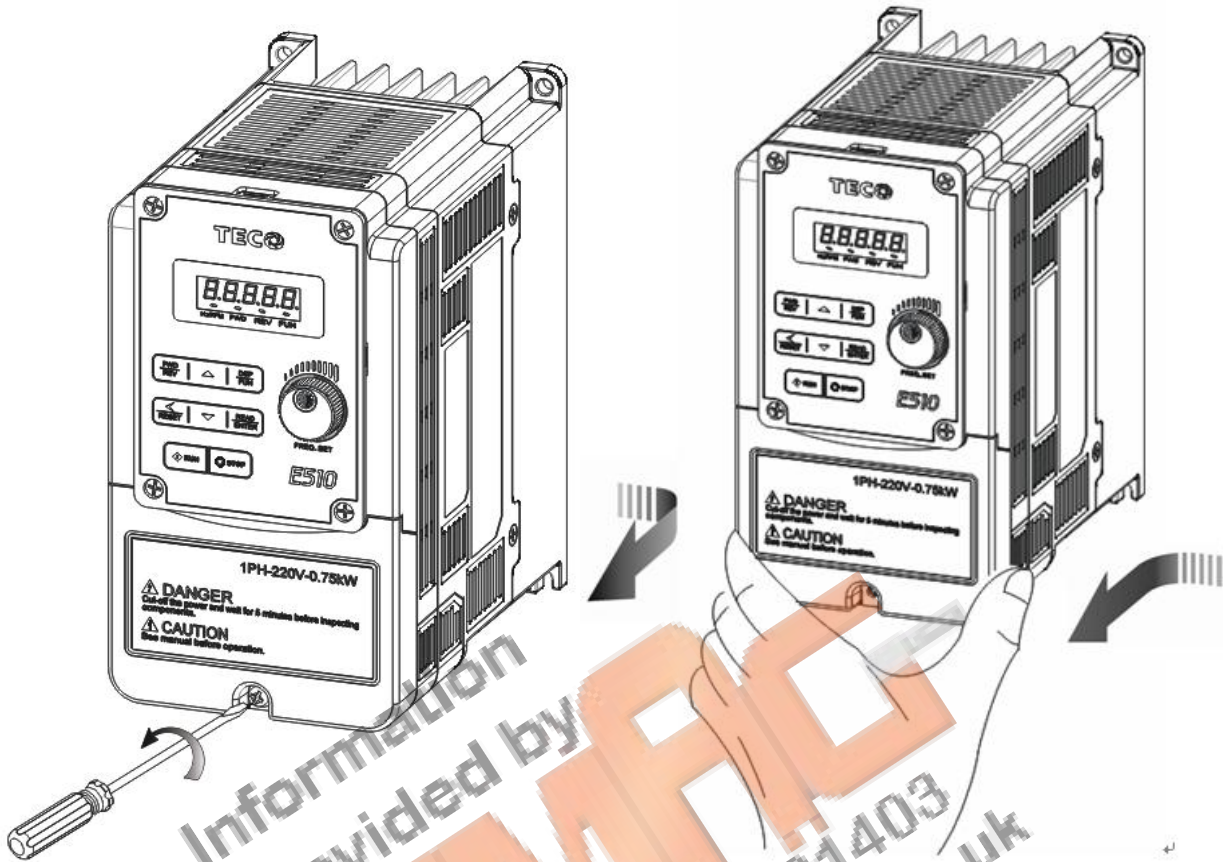

Step1: Loosen the screw

Step2: Remove the terminal cover

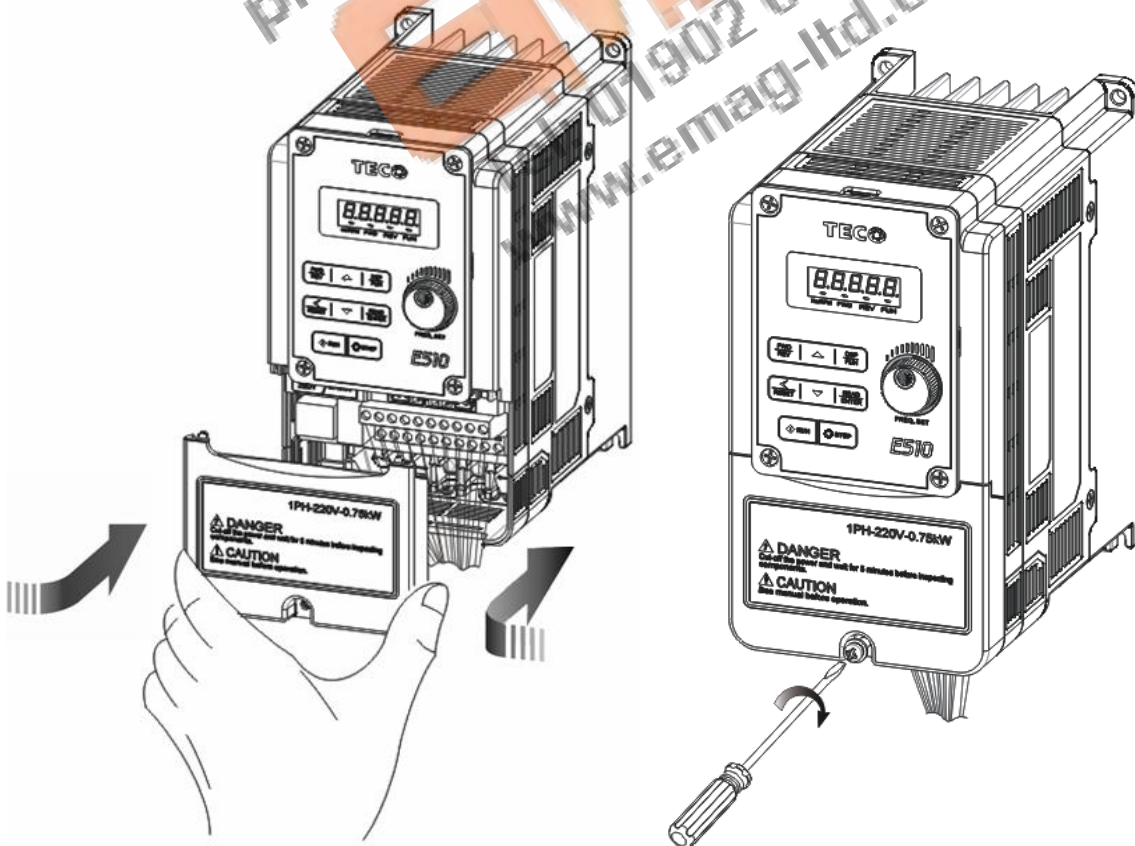

Step3: Wire&Re-install the cover

Step4: Tighten the screws



Frame 1(NEMA1)

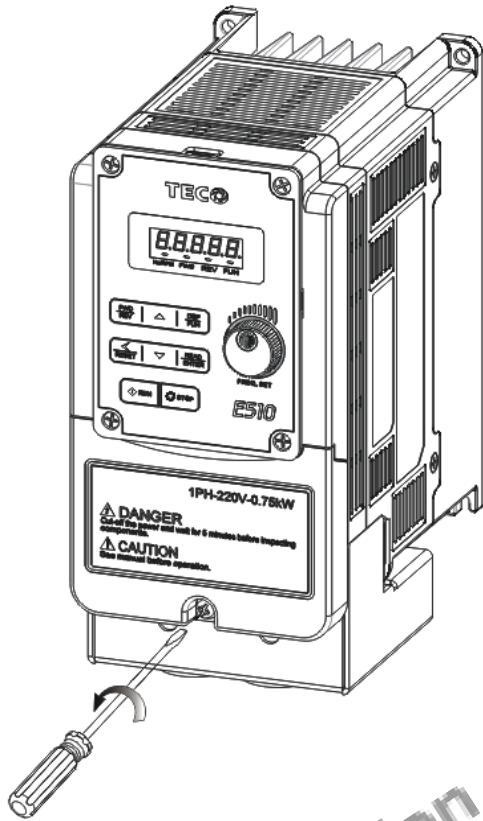

Step1: Loosen the screw

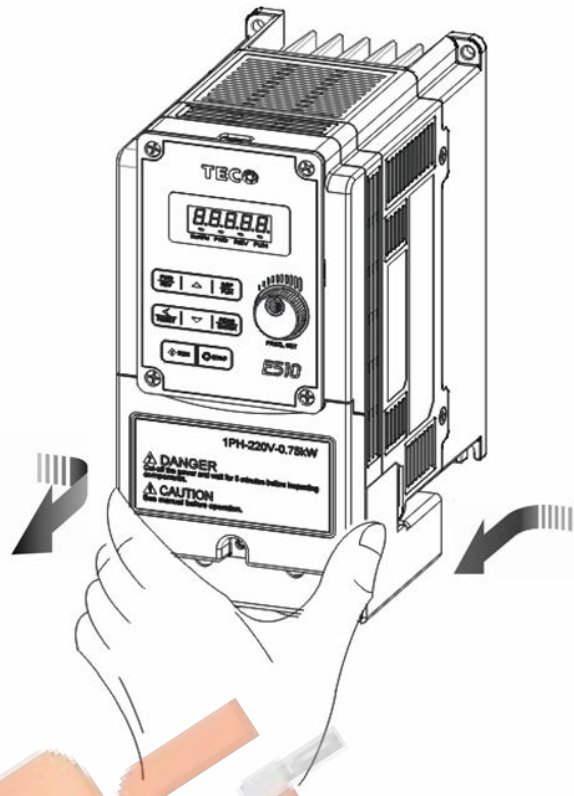

Step2: Remove the terminal cover

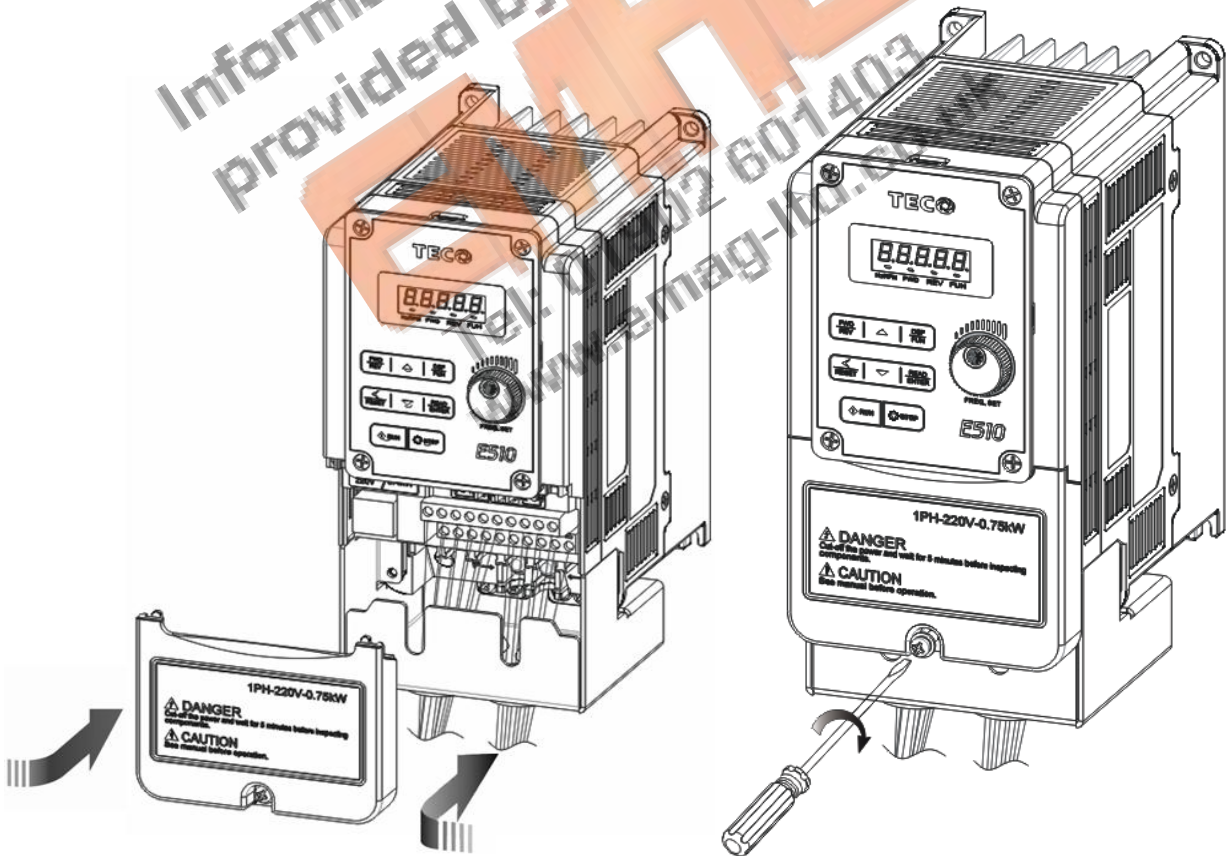

Step3: Wire & Re-install the cover

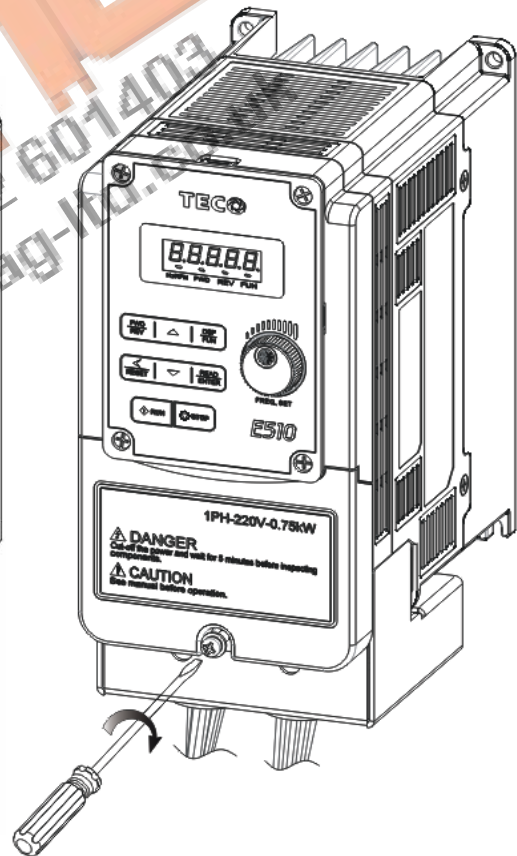

Step4: Tighten the screws

(b)Single/Three phase: 200V 2~3HP; Single phase: 200V 2~3HP; Three phase: 200V 5HP; 400V 3~5HP; Frame 2

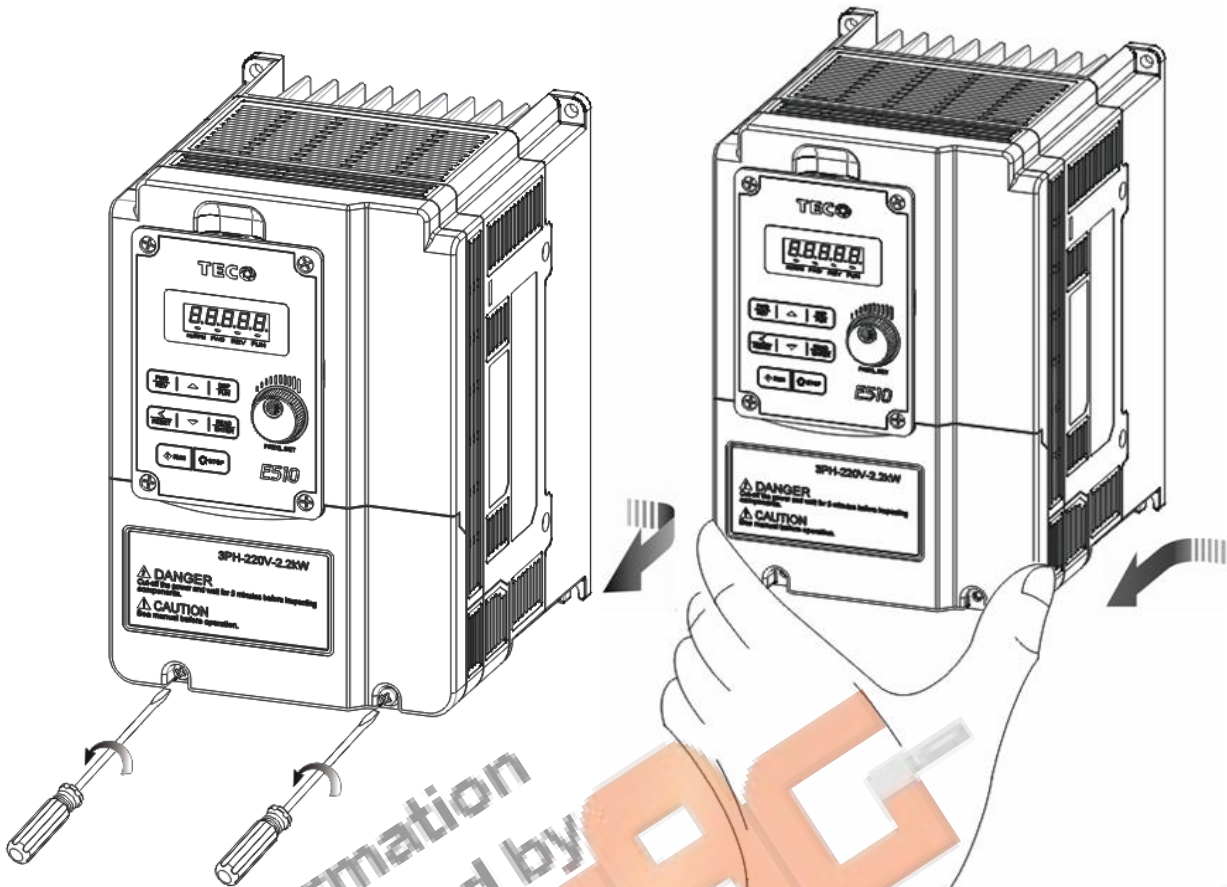

Step1: Loosen the screws

Step2: Remove the terminal cover

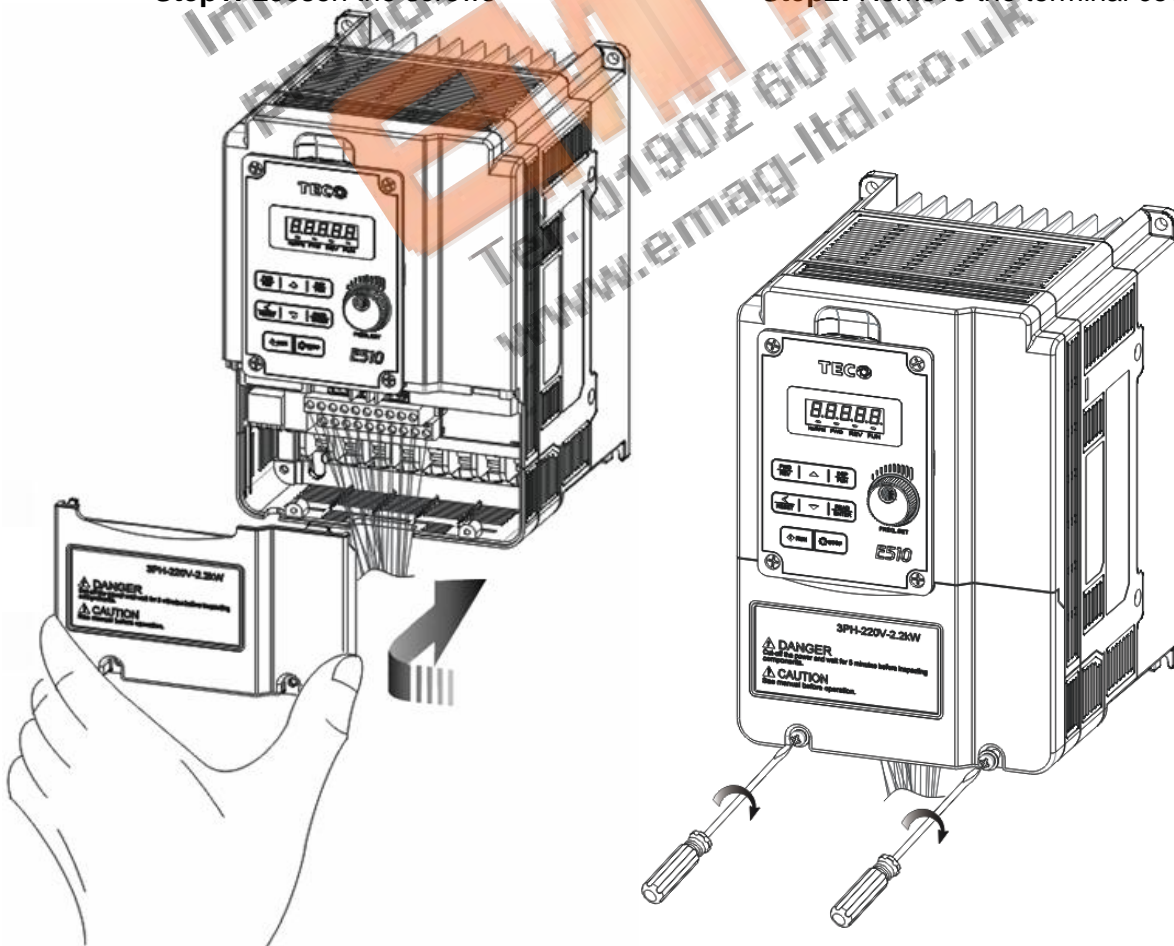

Step3: Wire & Re-install the cover

Step4: Tighten the screws

Frame 2(NEMA1)

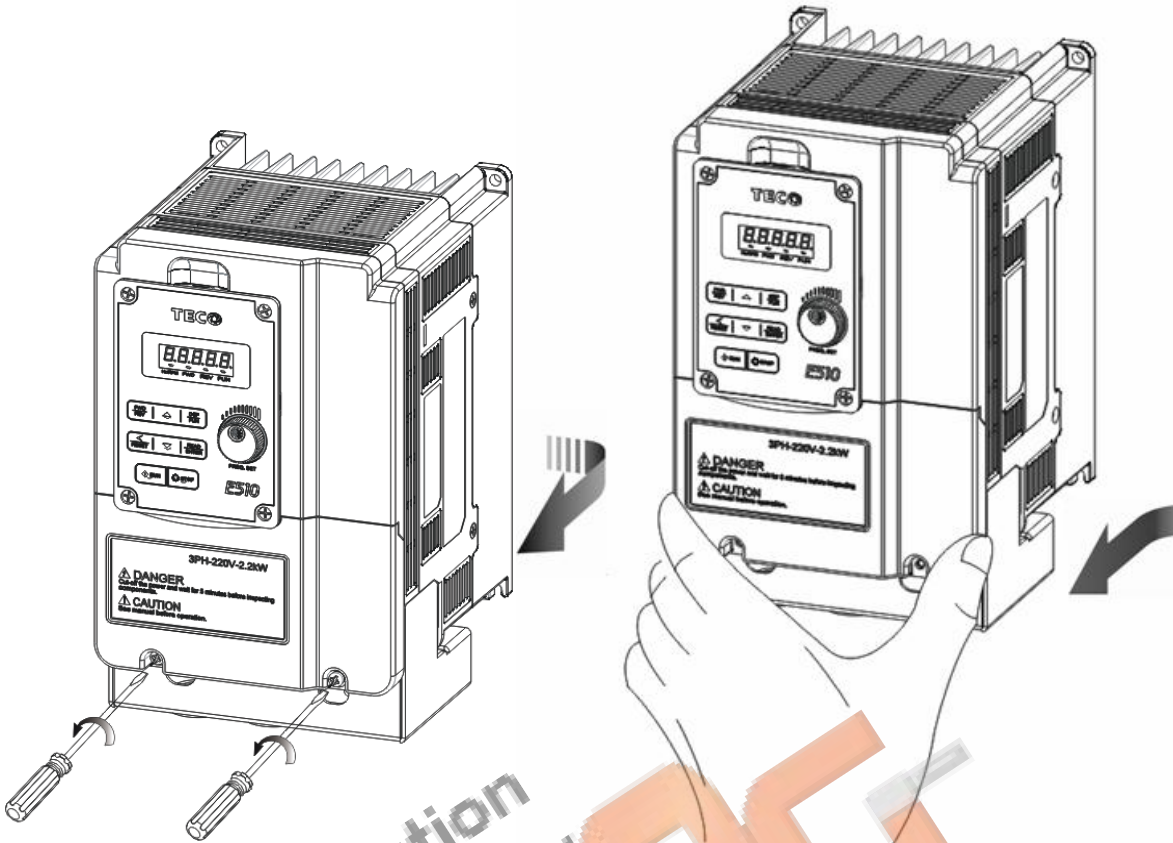

Step1: Loosen the screws

Step2: Remove the terminal cover

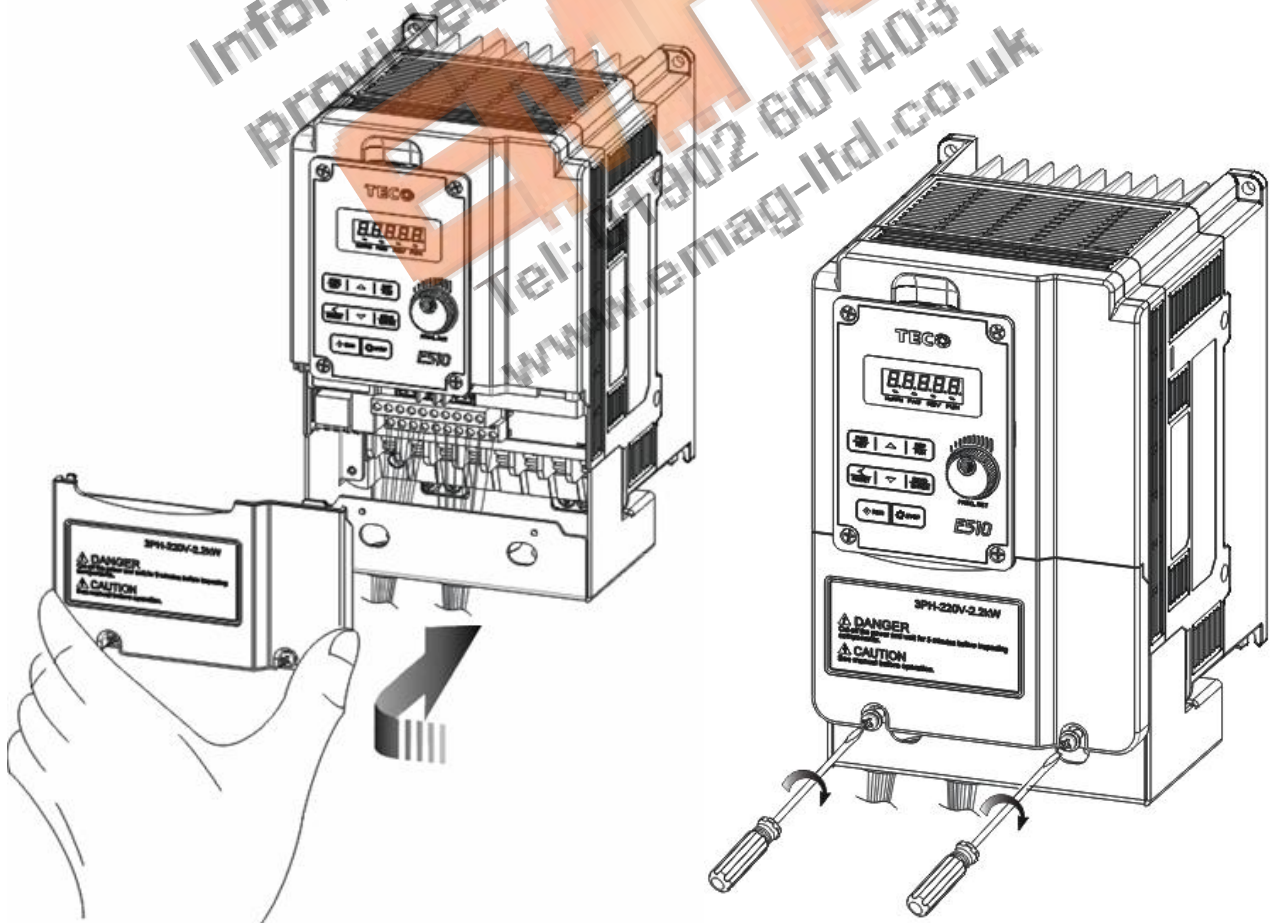

Step3: Wire&Re-install the cover

Step4: Tighten the screws



(c) Three phase: 200V 7.5~10HP; 400V 7.5~15HP;  
Frame 3

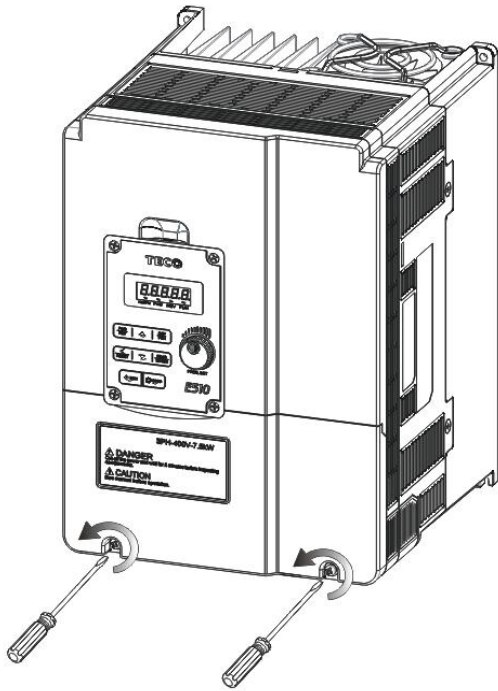

**Step1:** Loosen the screws

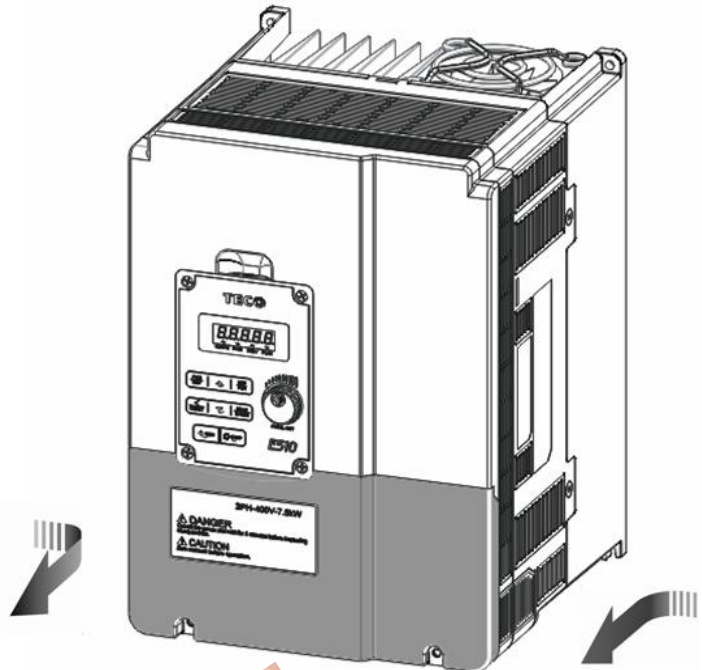

**Step2:** Remove the terminal cover

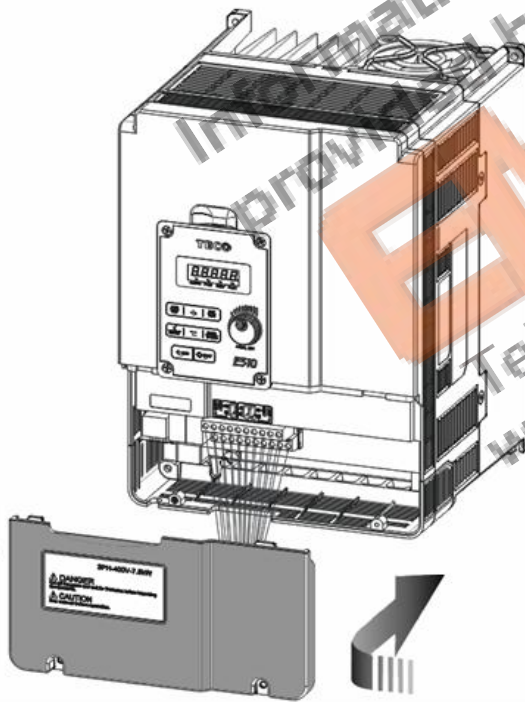

**Step3:** Wire & Re-install the cover

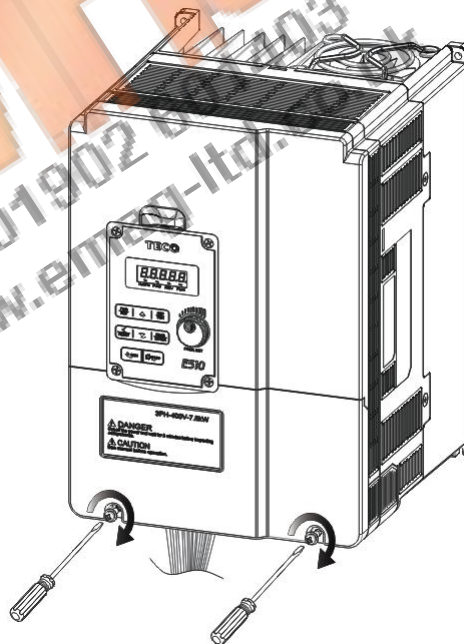

**Step4:** Tighten the screws

**Frame 3(NEMA1)**

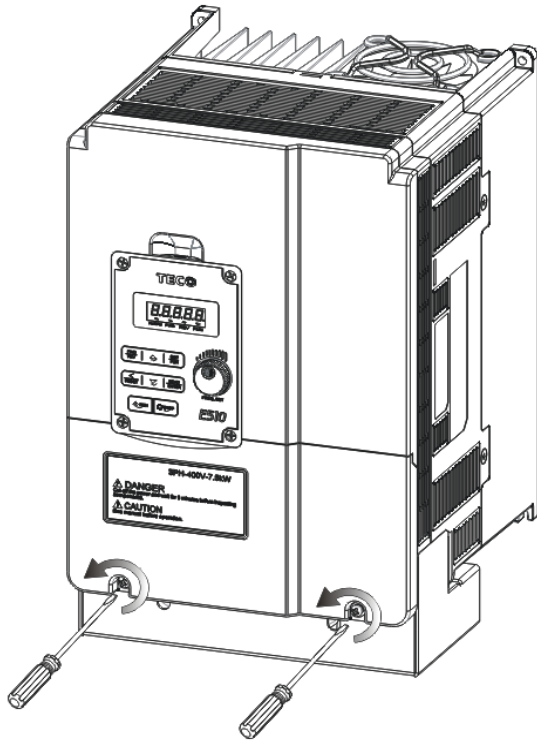

**Step1:** Loosen the screws

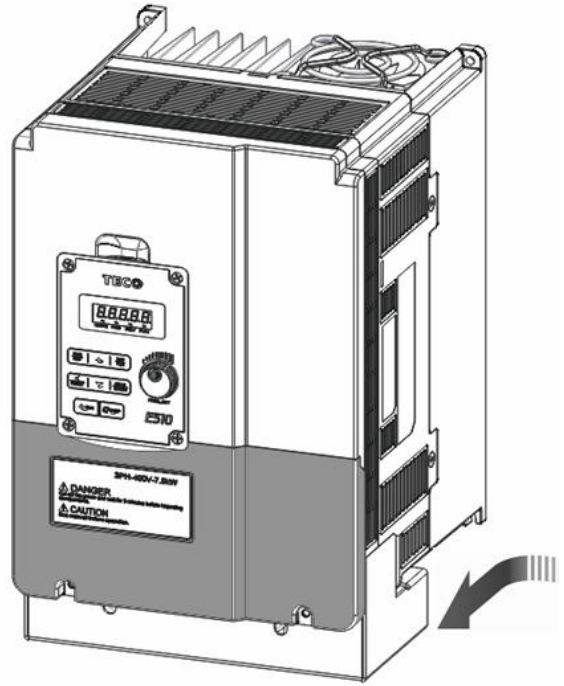

**Step2:** Remove the terminal cover

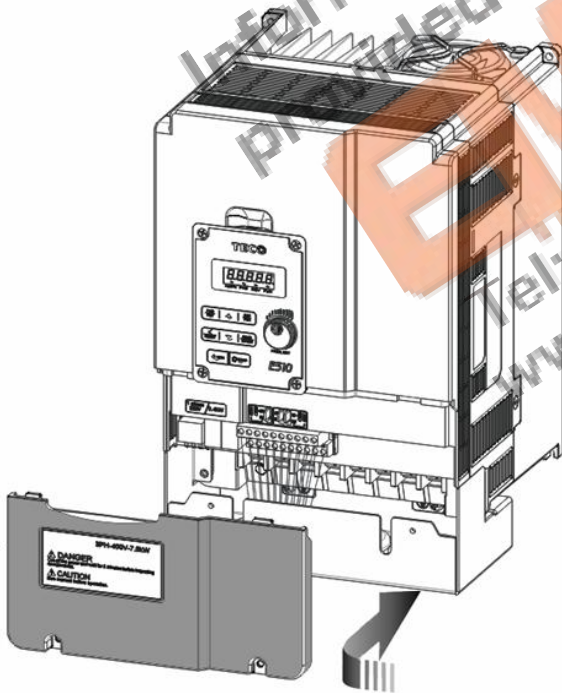

**Step3:** Wire & Re-install the cover

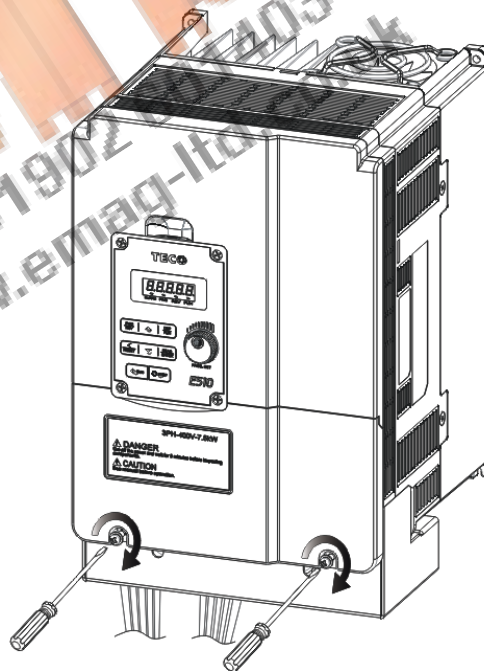

**Step4:** Tighten the screws



(d) Three phase: 200V 15~20HP; 400V 20~25HP;  
Frame 4

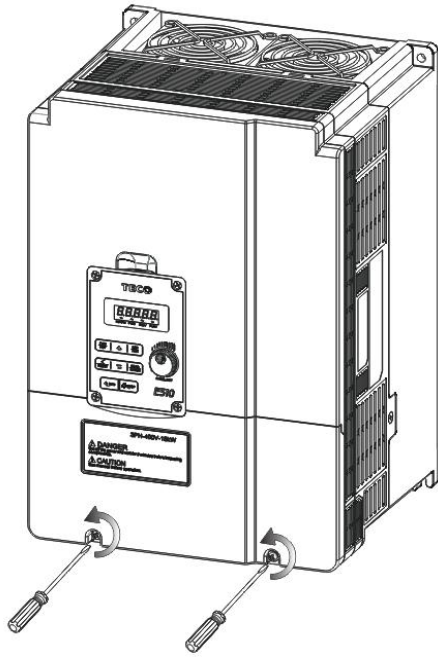

**Step1:** Loosen the screws

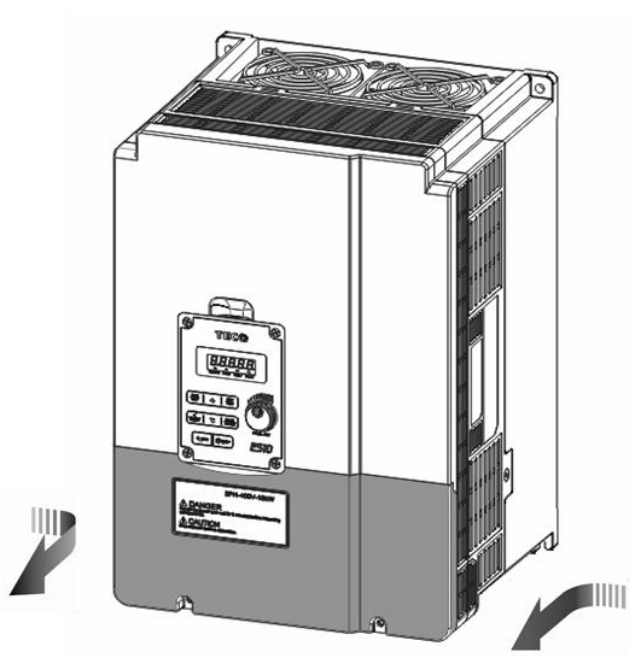

**Step2:** Remove the terminal cover

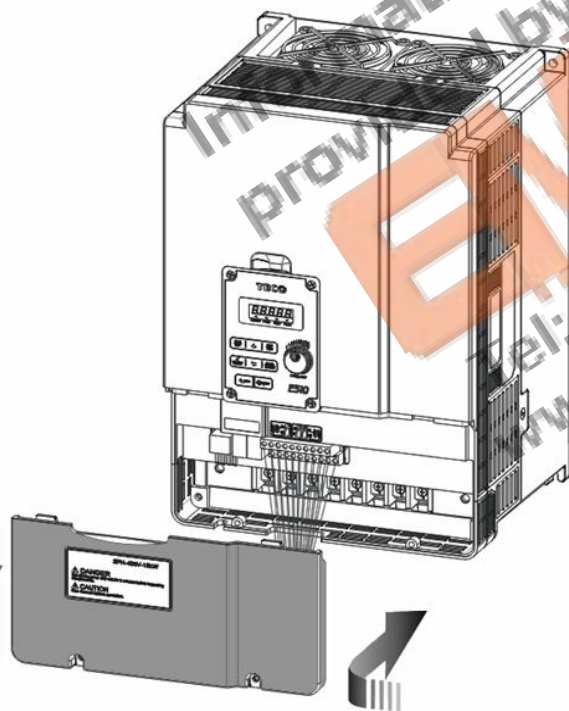

**Step3:** Wire & Re-install the cover

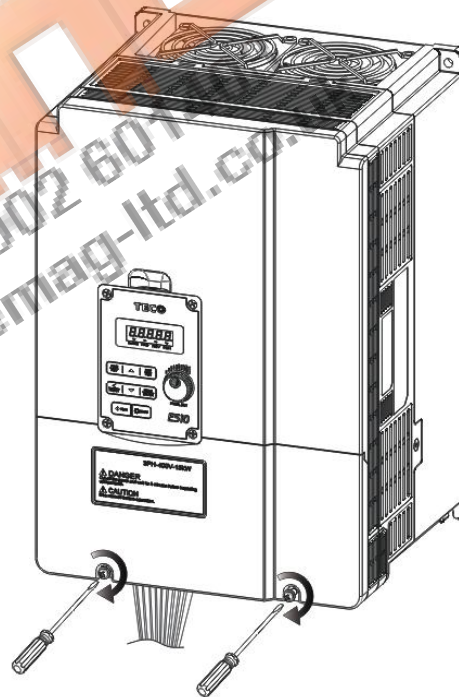

**Step4:** Tighten the screws

Frame 4(NEMA1)

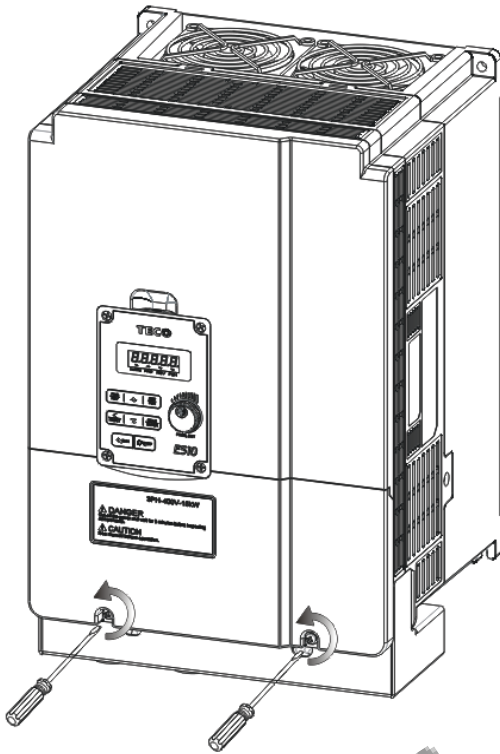

Step1: Loosen the screws

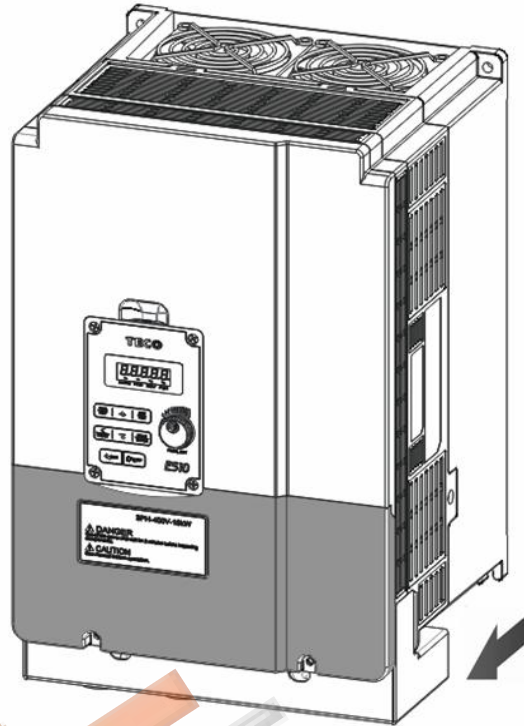

Step2: Remove the terminal cover

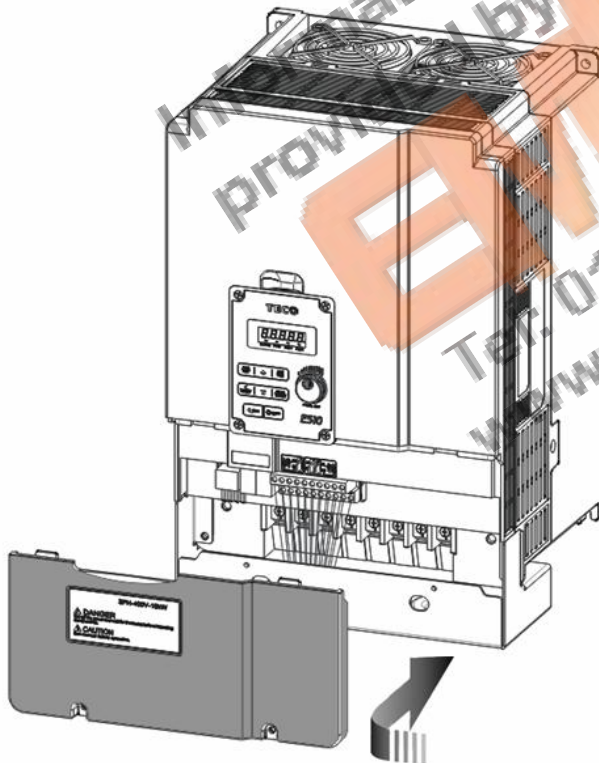

Step3: Wire & Re-install the cover

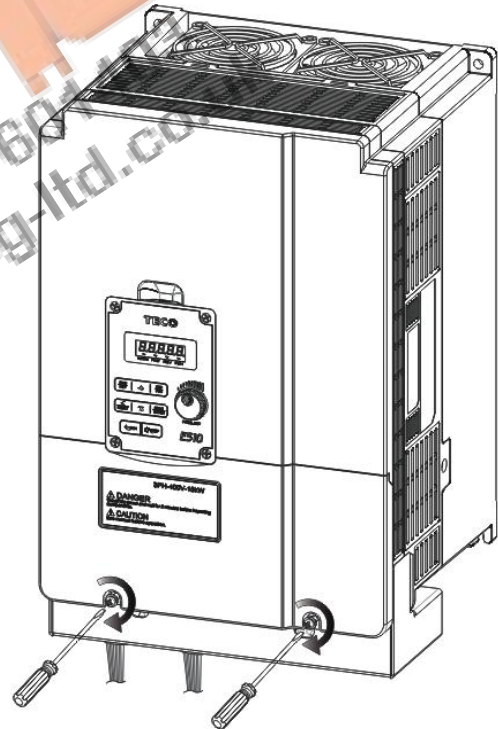

Step4: Tighten the screws

(e) Three phase: 400V 20~25HP;  
Frame 4(With Filter)

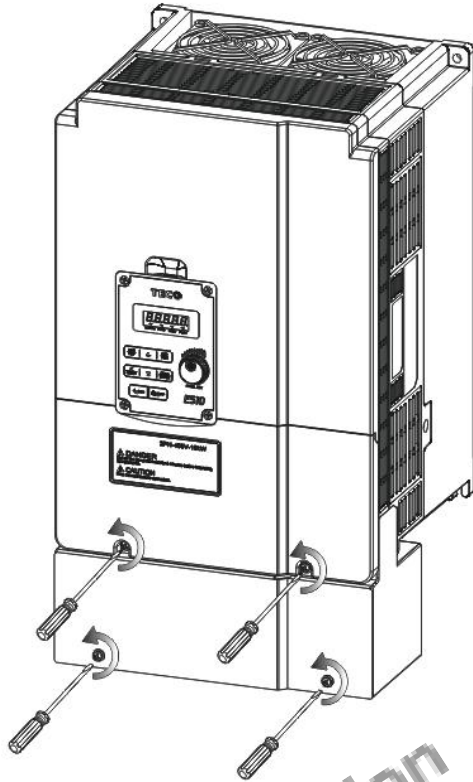

**Step1:** Loosen the screws

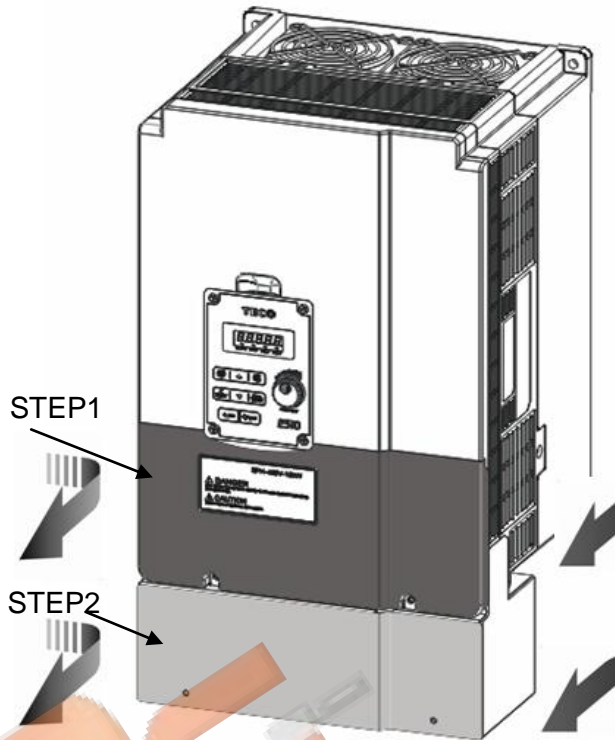

**Step2:** Remove the terminal cover

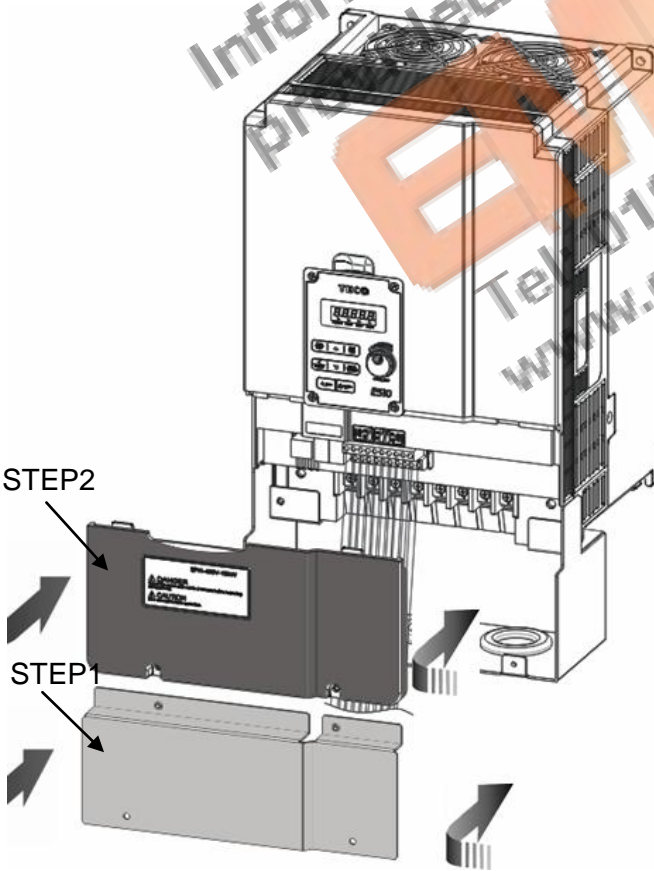

**Step3:** Wire&Re-install the cover

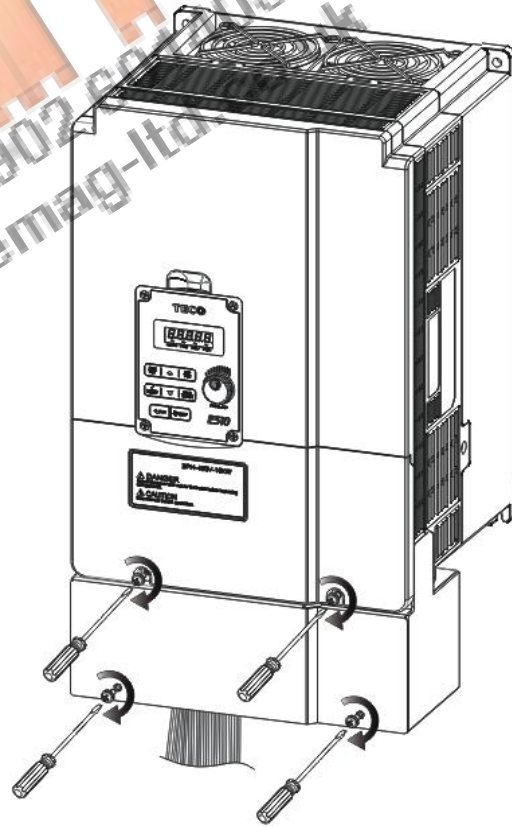

**Step4:** Tighten the screws

➤ IP66/NEMA 4X

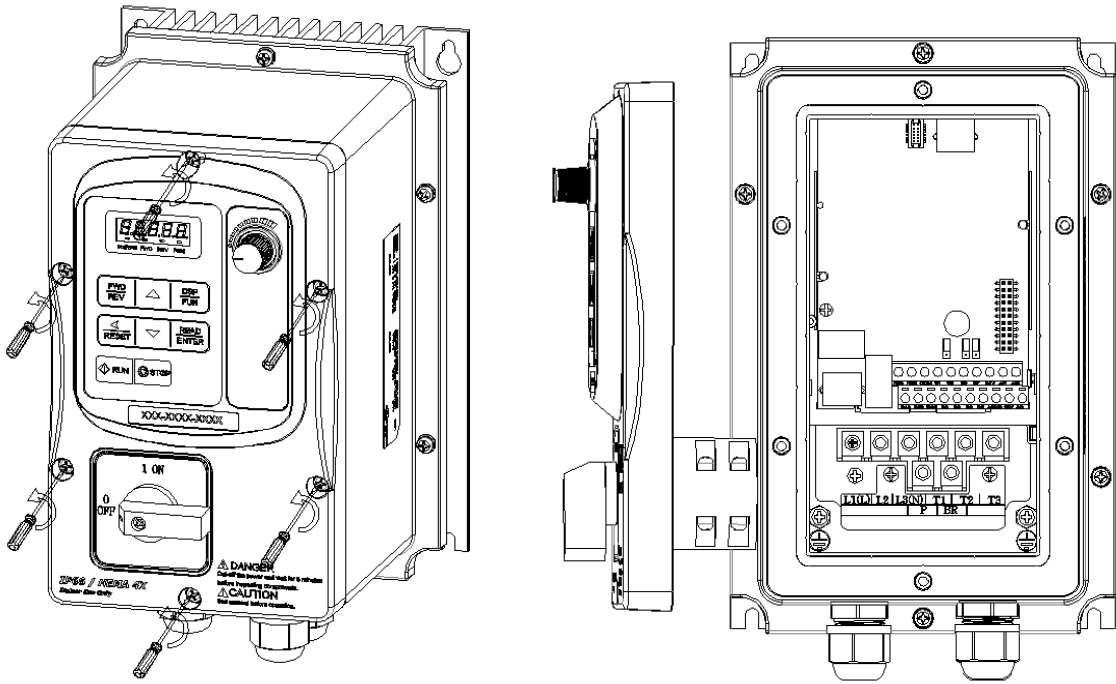

**Step 1:** Loosen the screws, lift and rest the cover next to the machine

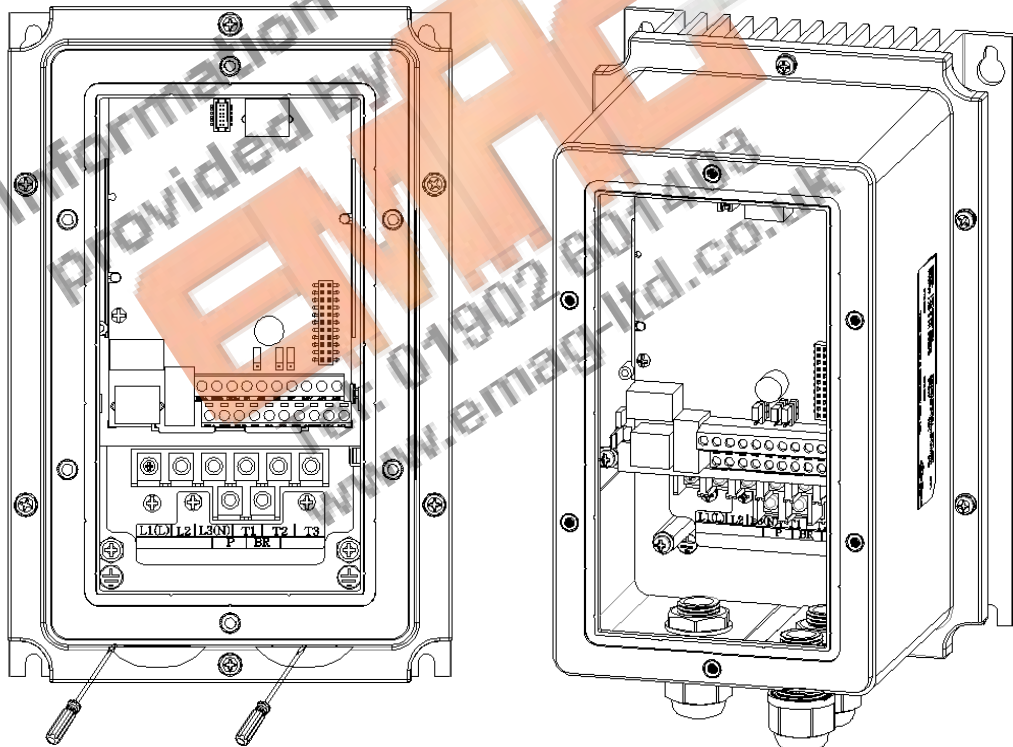

**Steps 2:** Remove the rubber plugs and use the waterproof cable glands provided to connect cables.



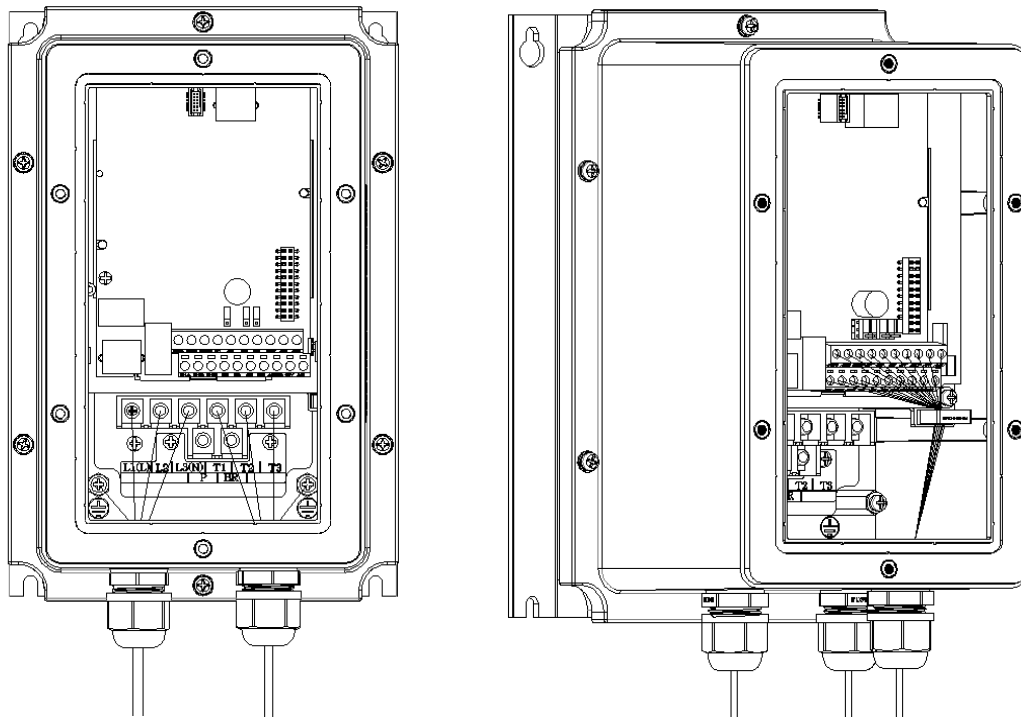

**Step 3: Connect power & motor cables through the cable glands to the correct terminals. Connect the control cable through the top gland and secure by the cable clamp.**

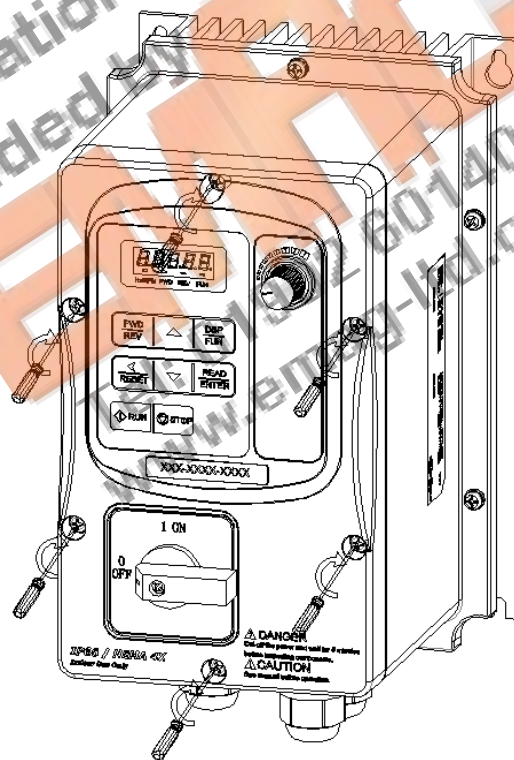

**Step 4: Ensure that the cable glands are tightened and the cover waterproof gasket is in place. Then place the cover and tighten the screws.**



### 3.2.2 Installation space

Provide sufficient air circulation space for cooling as shown in examples below.  
Install the Inverter on surfaces that provide good heat dissipation,

#### Single unit Installation

Install the inverter vertically to obtain effective cooling

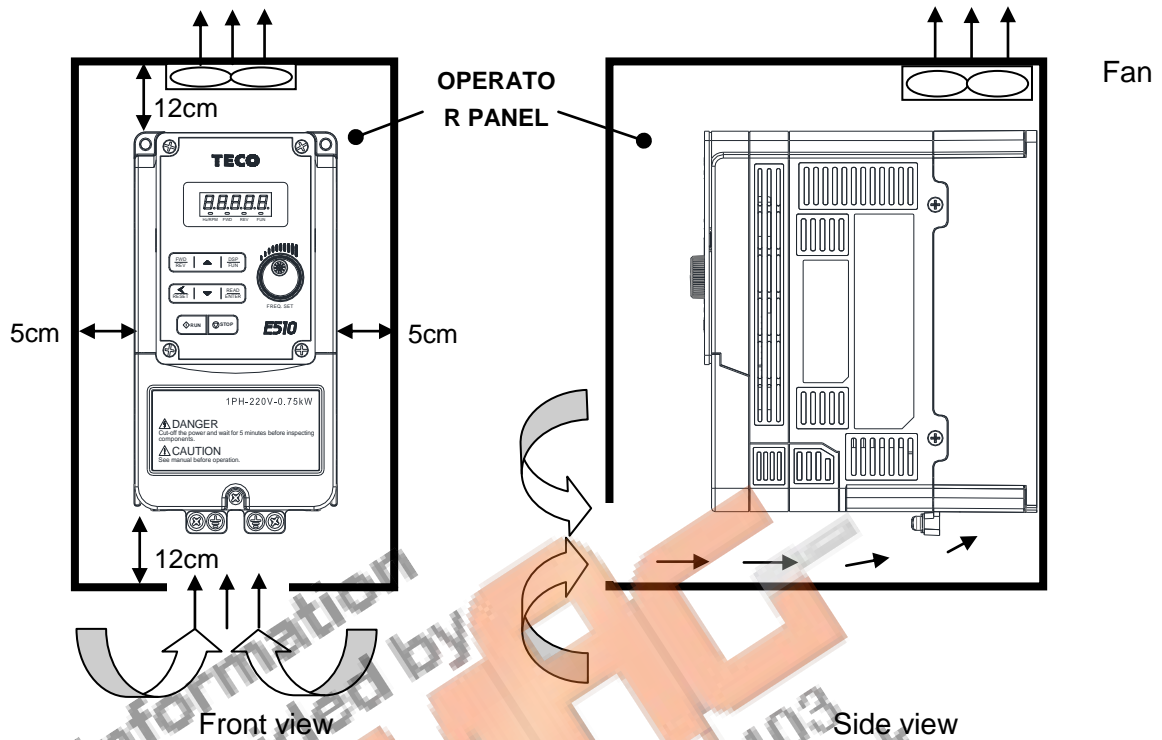

#### Side by side Installation

Provide the necessary physical space and cooling based on the ambient temperature and the heat loss in the panel

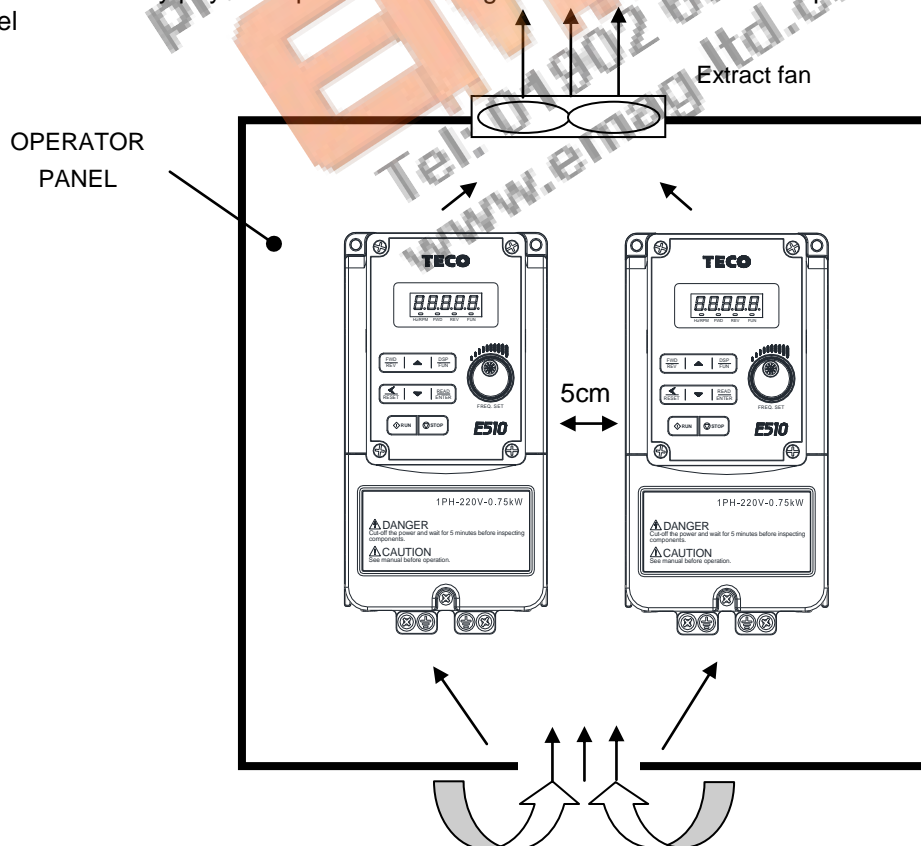

### 3.2.3 De-rating curves

Curves below show the applicable output current de-rate due to setting of carrier frequency and the ambient operating temperatures of 40 and 50 degrees C .

#### Frame1/2/3/4

(Single phase: 200V: 0.5~3HP; Single /Three phase: 200V: 0.5~3HP;  
Three phase: 200V: 2~20HP 400V: 1~25HP)

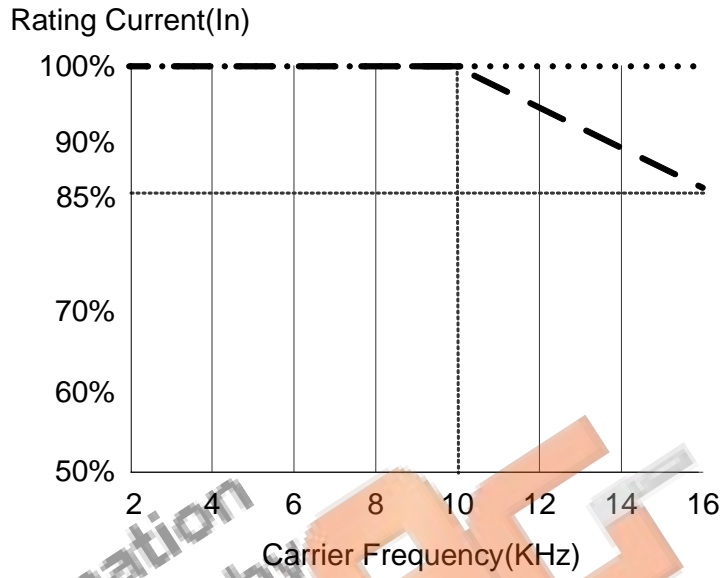

Note: ..... De-rate curve for ambient temperature of 40 degree C.  
----- De-rate curve for ambient temperature of 50 degree C.

Information provided by EMAG  
Tel: 01902 601403  
www.emag-ltd.co.uk

## 3.3 Wiring Guidelines

### 3.3.1 Power Cables

Supply power cable must be connected to TM1 terminal block, terminals L1(L), L2, L3(N). L1(L) and L3(N) for single phase 230V supply.

Motor cable must be connected to TM1 terminals. T1, T2, T3.

**Warning:-** Connection of supply line cable to terminals T1,T2, T3 will result in serious damage to the drive components.

**Example power connections: Inverter with dedicated power line.**

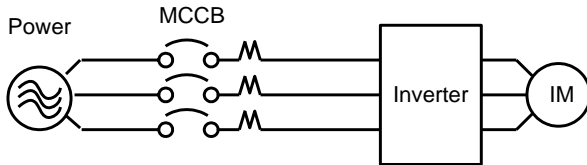

- Install a Supply RFI filter or Isolation transformer when the power source is shared with other high power electrical equipment as shown below.

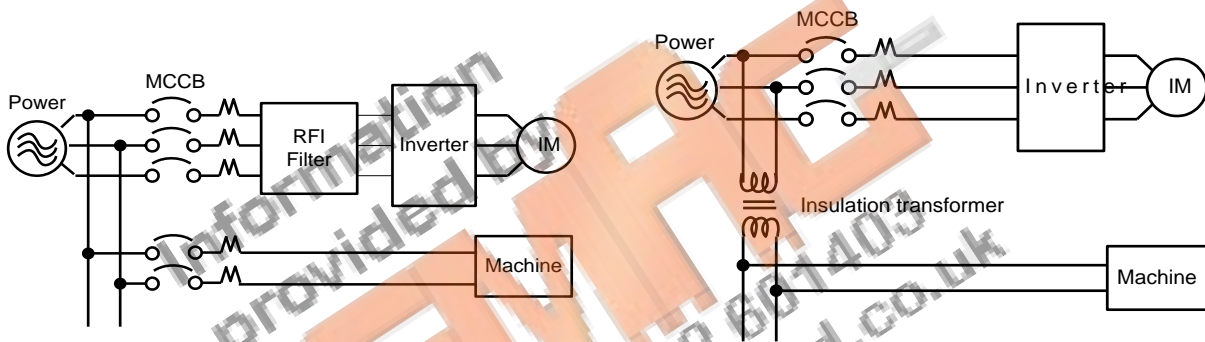

### 3.3.2 Control Cable selection and Wiring

Control cables should be connected to terminal block TM2.

Choose power & Control cables according to the following criteria:-

- Use copper wires with correct diameter and temperature rating of 65/70°C.
- Minimum cable voltage rating for 200V type inverters should be 300VAC. Minimum cable voltage rating for 400V type inverters should be 600VAC.
- Route all cables away from other high voltage or high current power lines to reduce interference effects.
- Use a twisted pair shielded cable and connect the shield (screen) wire to the ground terminal at the inverter end only. Cable length should not exceed 50 meters.

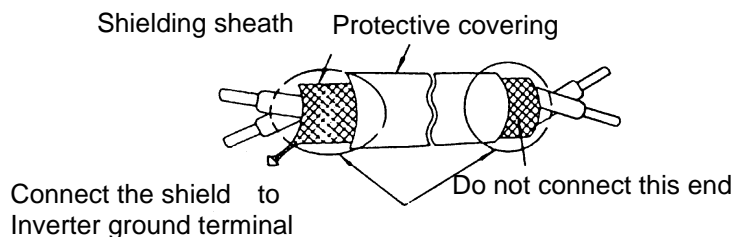

### 3.3.3 Wiring and EMC guidelines

For effective interference suppression, do not route power and control cables in the same conduit or trunking.

To prevent radiated noise, motor cable should be put in a metal Conduit. Alternatively an armored or shielded type motor cable should be used.

For effective suppression of noise emissions the cable armor or shield must be grounded at both ends to the motor and the inverter ground. These connections should be as short as possible.

Motor cable and signal lines of other control equipment should be at the least 30 cm apart.

E510 has a built in Class "A" EMC filter to first Environment Restricted. (Category C2).

#### Typical Wiring.

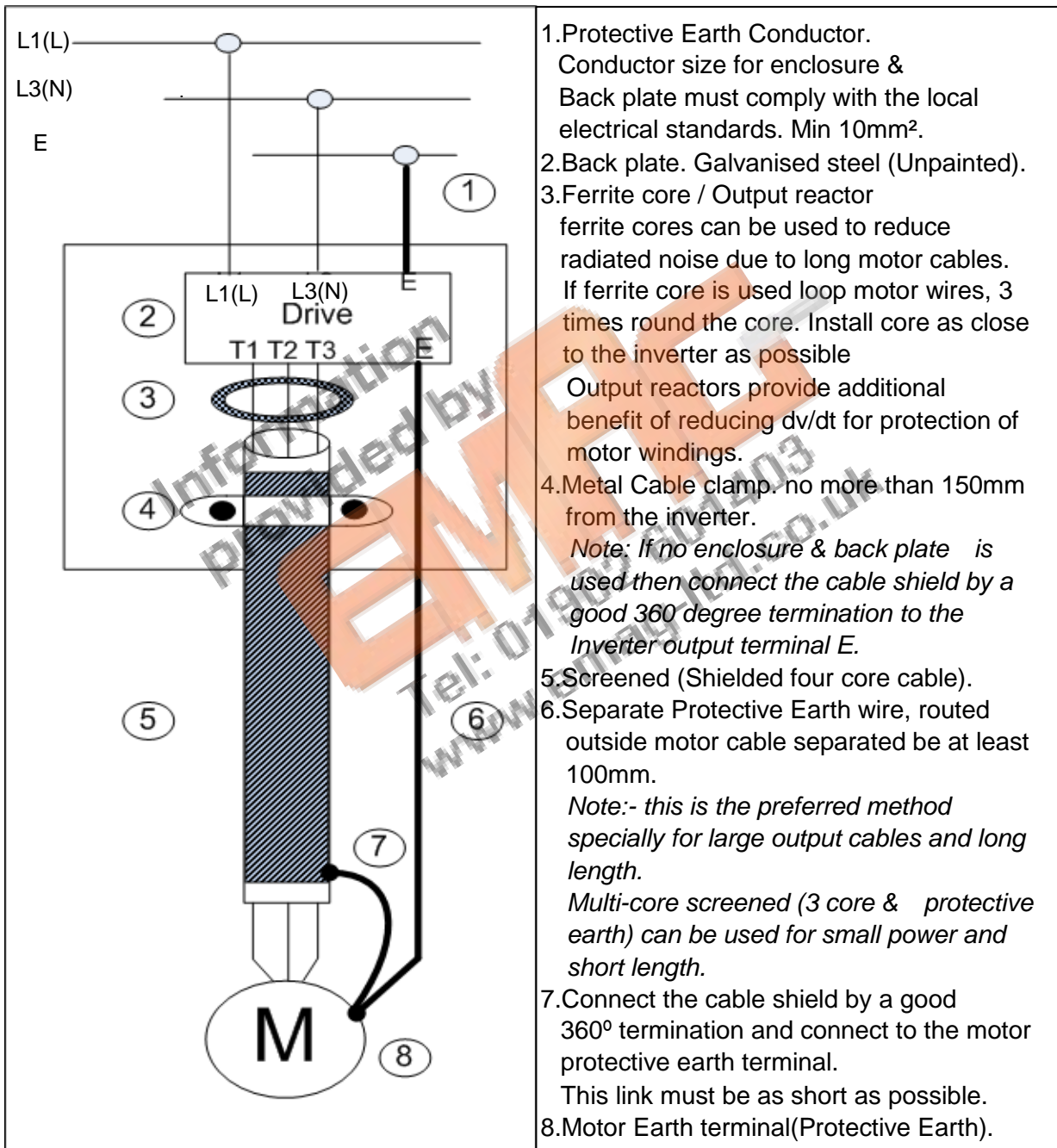

### 3.3.4 Failure liability

- Teco bears no responsibility for any failures or damaged caused to the inverter if the recommendations in this instruction manual have not been followed specifically points listed below,
- If a correctly rated Fuse or Circuit breaker has not been installed between the power source and the inverter.
- If a magnetic contactor, a phase capacitor, burst absorber and LC or RC circuits have been connected between the inverter and the motor.
- If an incorrectly rated three-phase squirrel cage induction motor has been used

**Note:**

When one inverter is driving several motors, the total current of all motors running simultaneously must be less than the rated current of the inverter, and each motor has to be equipped with a correctly rated thermal overload relay.

- ※1. "Only Intended For Use In A Pollution Degree 2 Environment" or equivalent.
- ※2. Since there is no over speed protection there will be no liability due to overspeed damage.

Information  
provided by  
**EMAG**  
Tel: 01902 601403  
[www.emag-ltd.co.uk](http://www.emag-ltd.co.uk)

### 3.3.5 Considerations for peripheral equipment

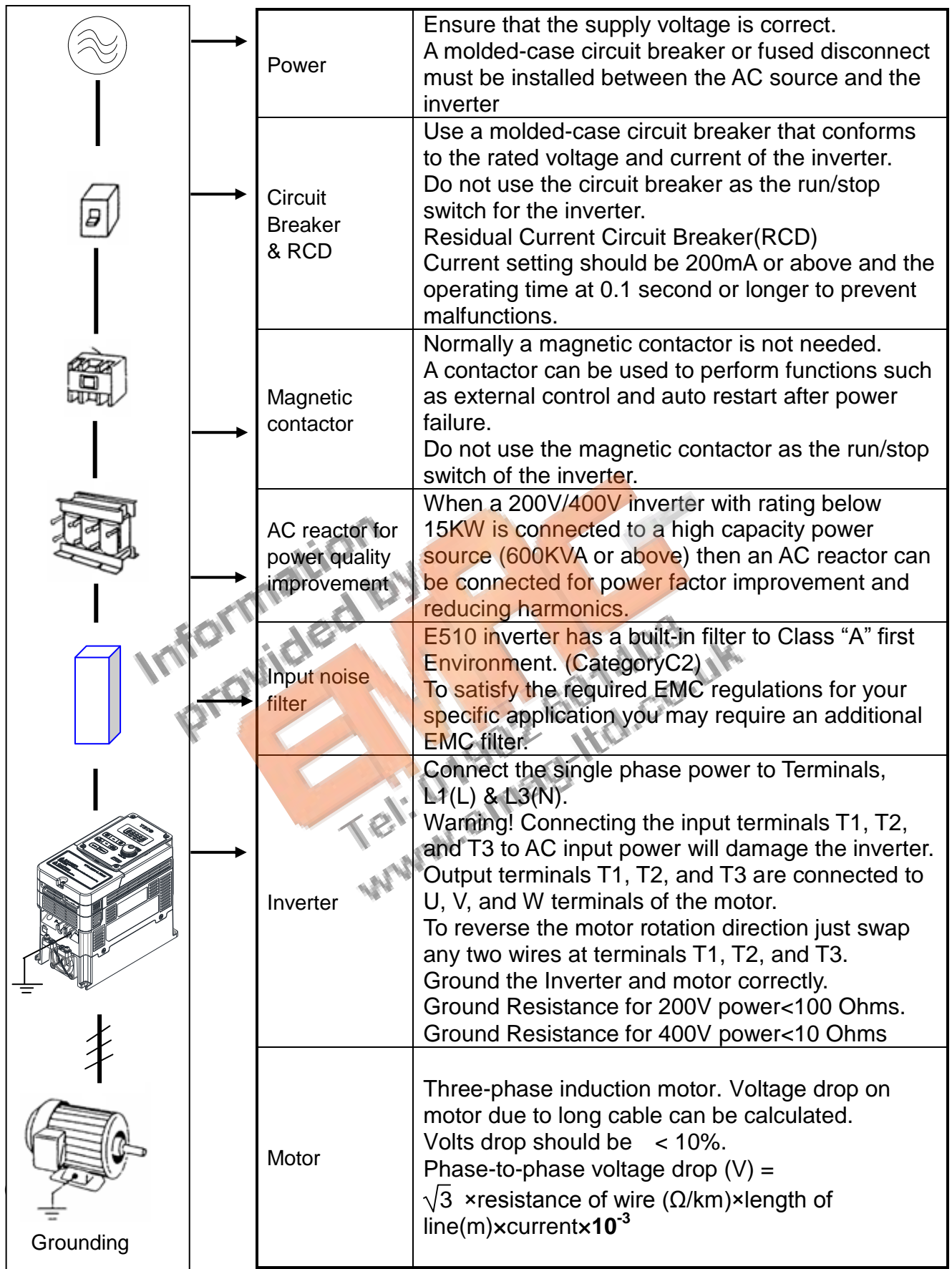



### 3.3.6 Ground connection

Inverter ground terminal must be connected to installation ground correctly and according to the required local wiring regulations.

- Ground cable size must be according to the required local wiring regulations. Ground connection should be as short as possible.
- Do not share the ground of the inverter with other high current loads (Welding machine, high power motors). Ground each unit separately.
- Ensure that all ground terminals and connections are secure
- Do not make ground loops when several inverters share a common ground point.

**Note:** Please leave at least 5cm while installing inverter side by side in order to provide enough cooling space.

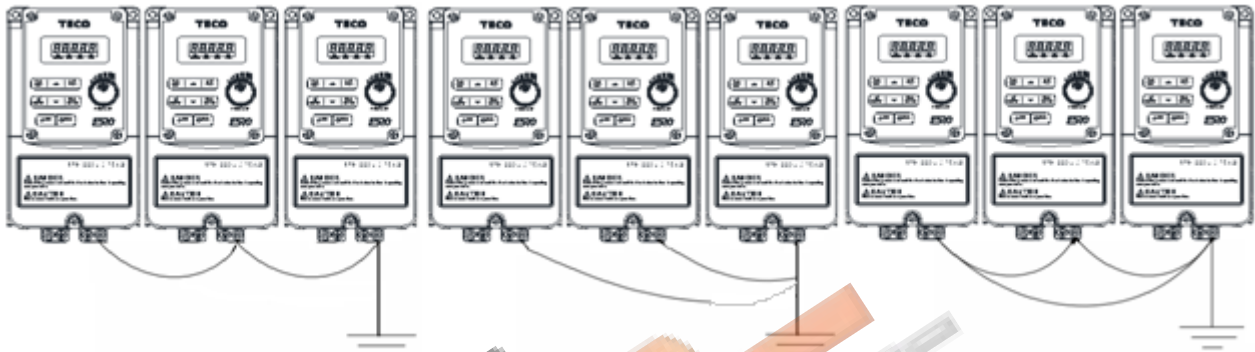

(a) Correct

(b) Correct

(c) Incorrect

Information  
provided by  
**EMAG**  
Tel: 01902 601403  
www.emag-ltd.co.uk

### 3.3.7 Inverter exterior

#### 3.3.7.1 IP20/NEMA 1 exterior

(a) Single/Three phase: 200V 0.5~1HP; Single phase: 200V 0.5~1HP; Three phase: 200V 2HP; 400V 1~2HP;

##### E510-Frame 1

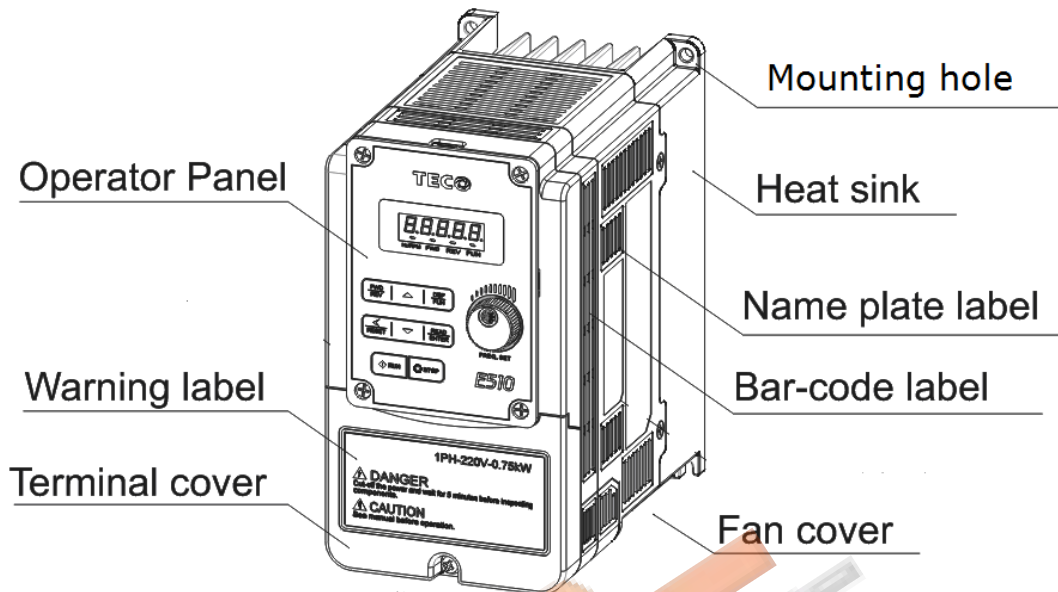

##### E510-Frame 1(NEMA1)

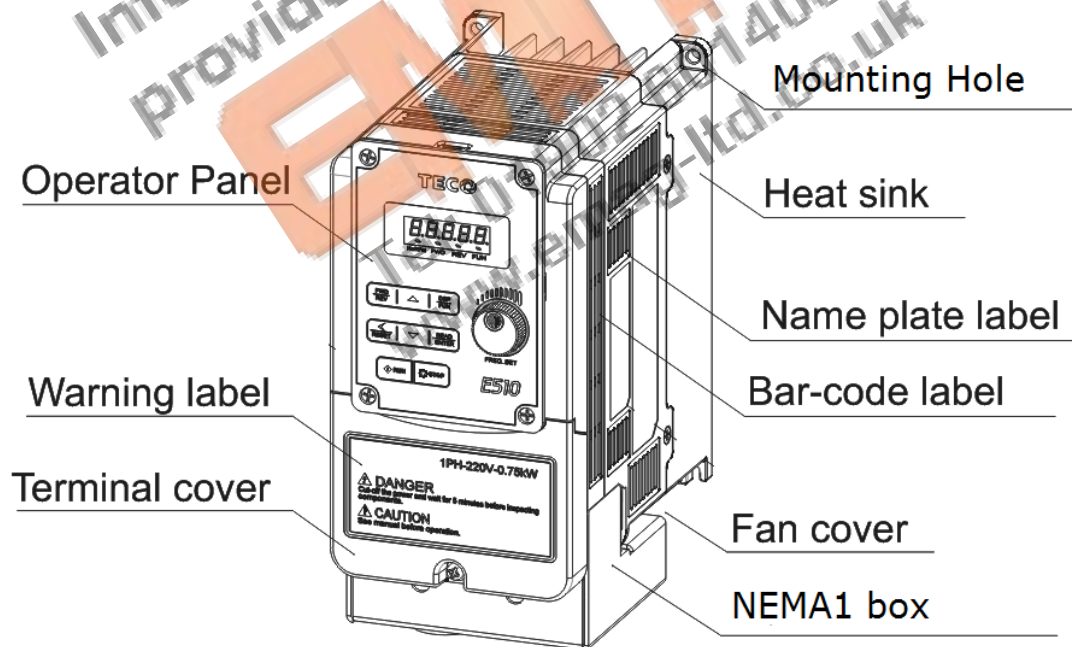

(b) Single/Three phase: 200V 2~3HP; Single phase: 200V 2~3HP; Three phase: 200V 5HP; 400V 3~5HP;

E510-Frame2

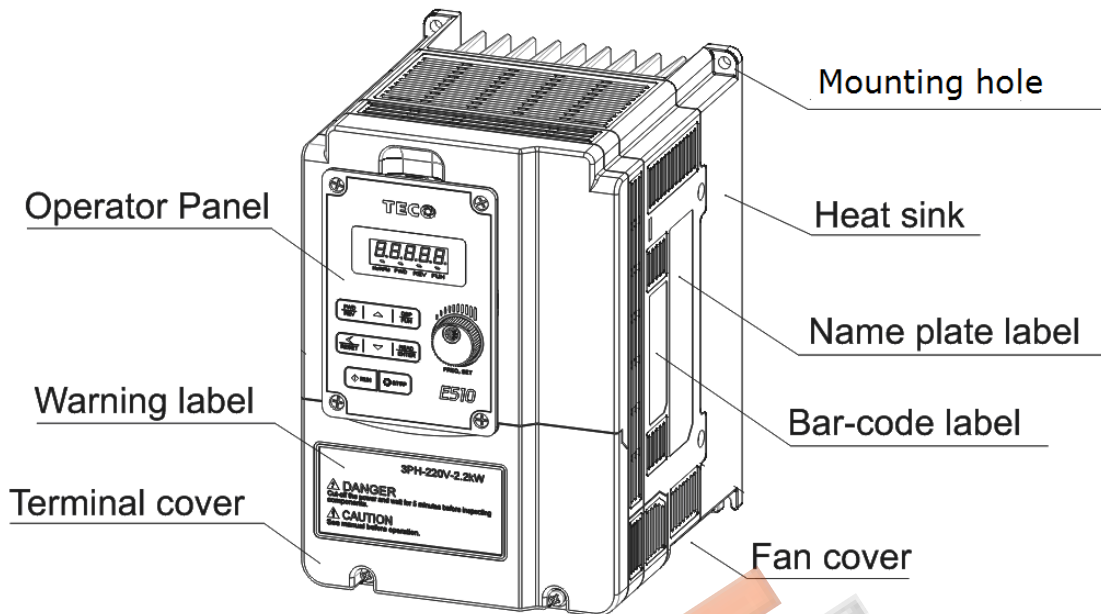

E510-Frame2(NEMA1)

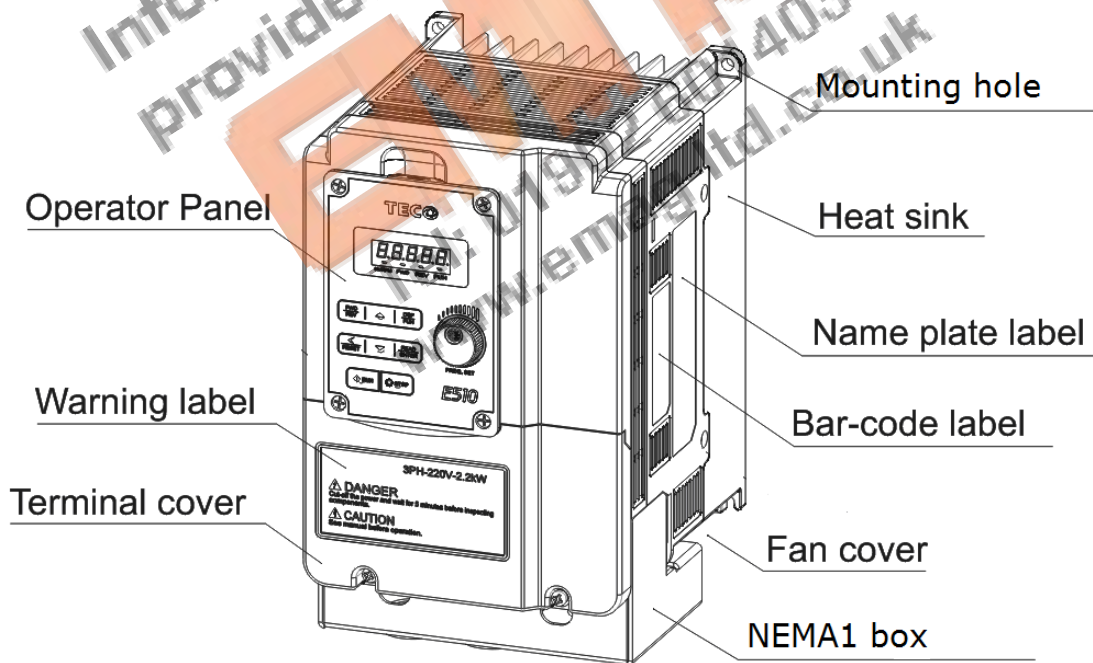

(c) Three phase: 200V 7.5~10HP; 400V 7.5~15HP;

E510-Frame 3

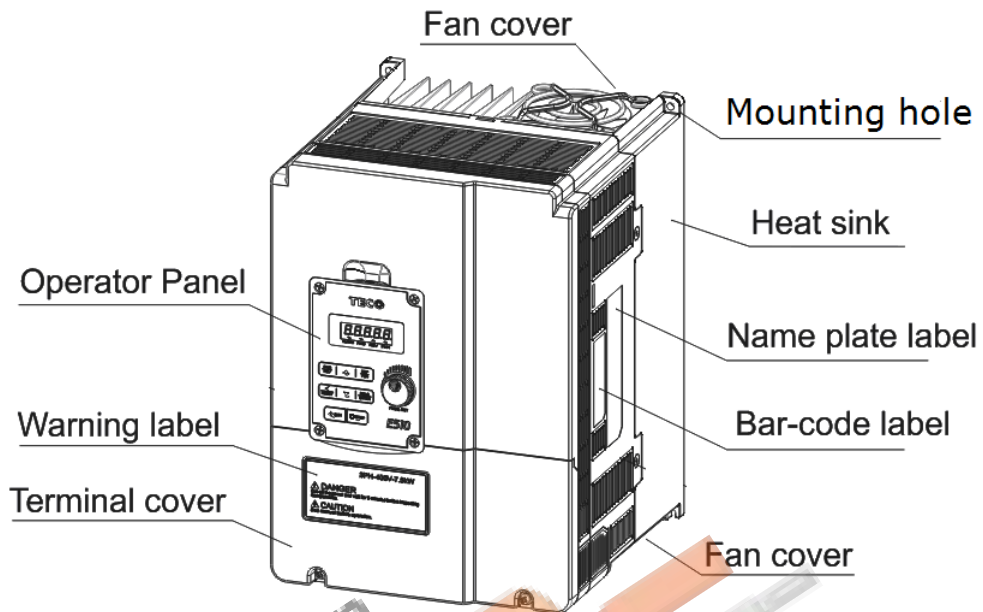

E510-Frame 3(NEMA1)

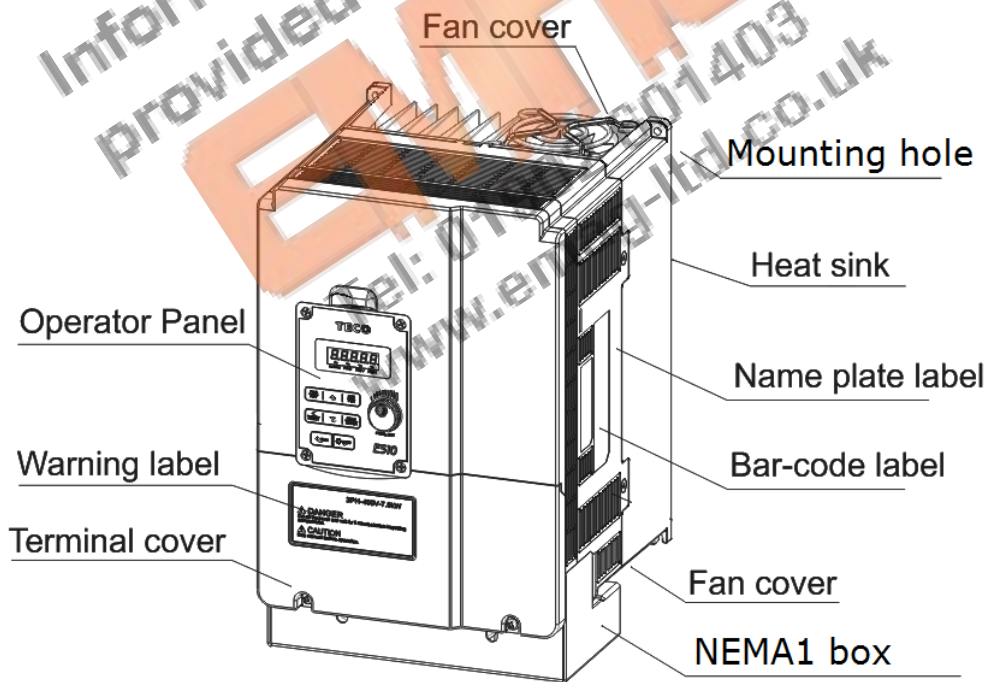

(d) Three phase: 200V 15~20HP; 400V 20~25HP;

E510-Frame 4

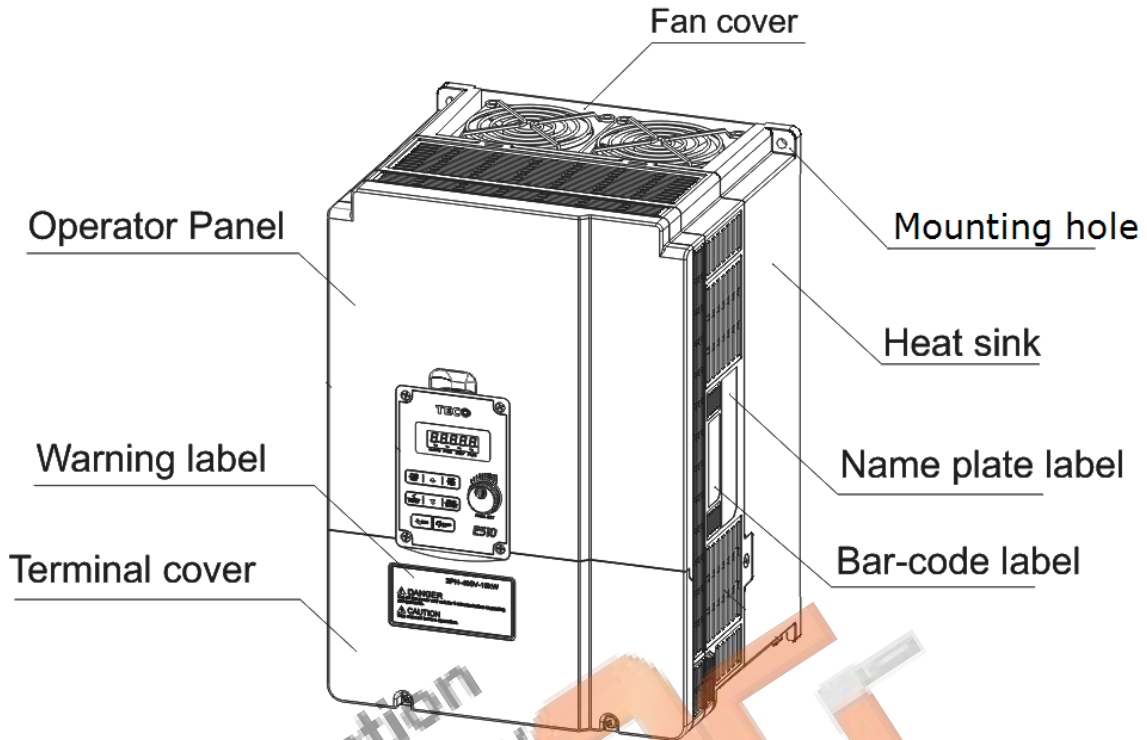

E510-Frame 4(NEMA1)

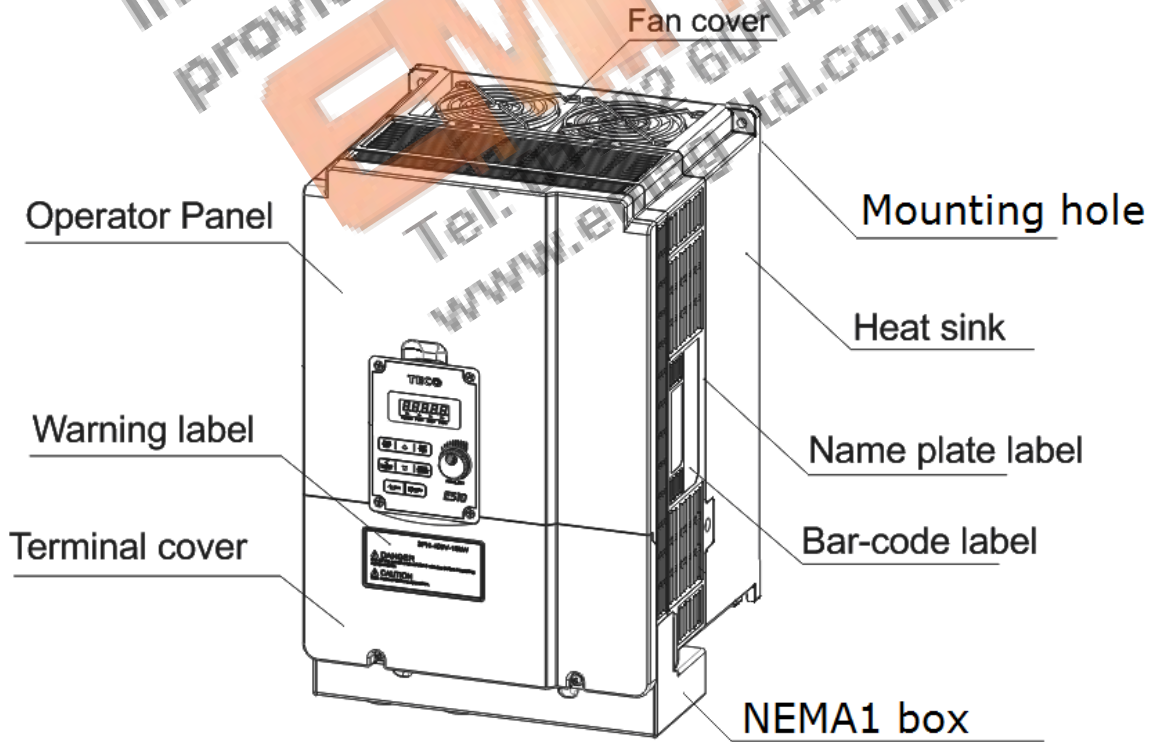

(e) Three phase: 400V 20~25HP;

E510-Frame 4 (With Filter)

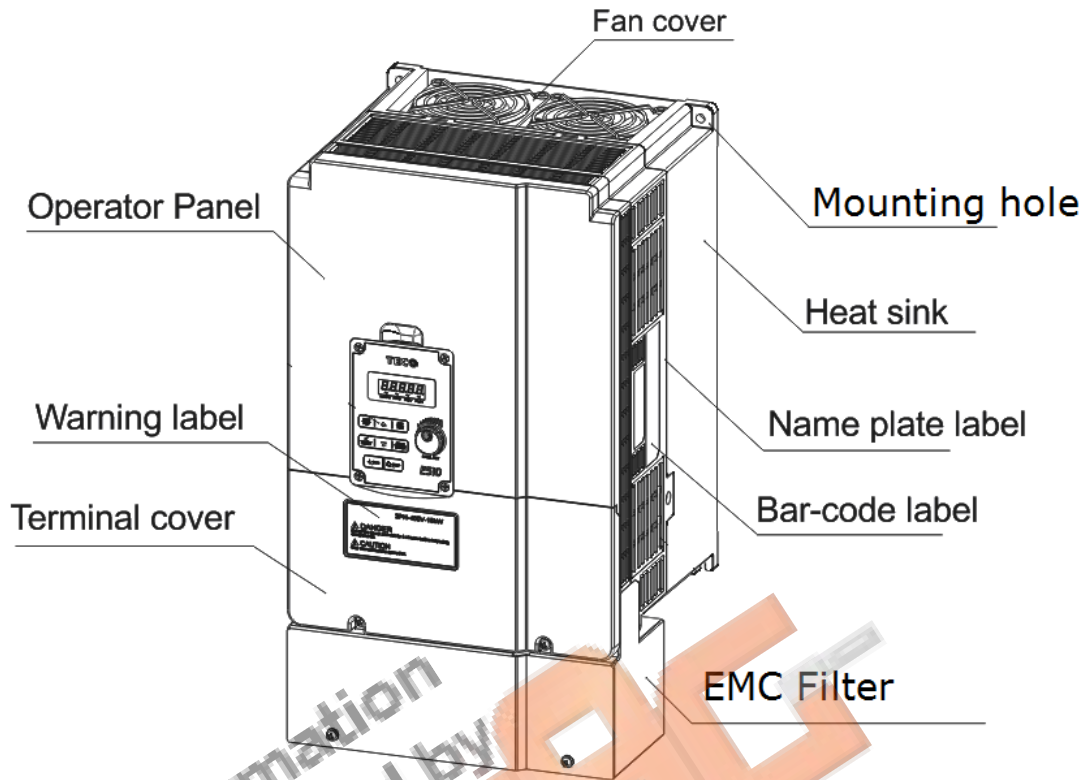

3.3.7.2 IP66/NEMA 4X exterior

(a) Single/Three phase : 200V 0.5~1HP ; Single phase : 200V 0.5~1HP ; Three phase : 200V 2HP ; 400V 1~2HP

E510-Frame 1(IP66/NEMA 4X With/Without VR and power switches depending on the model)



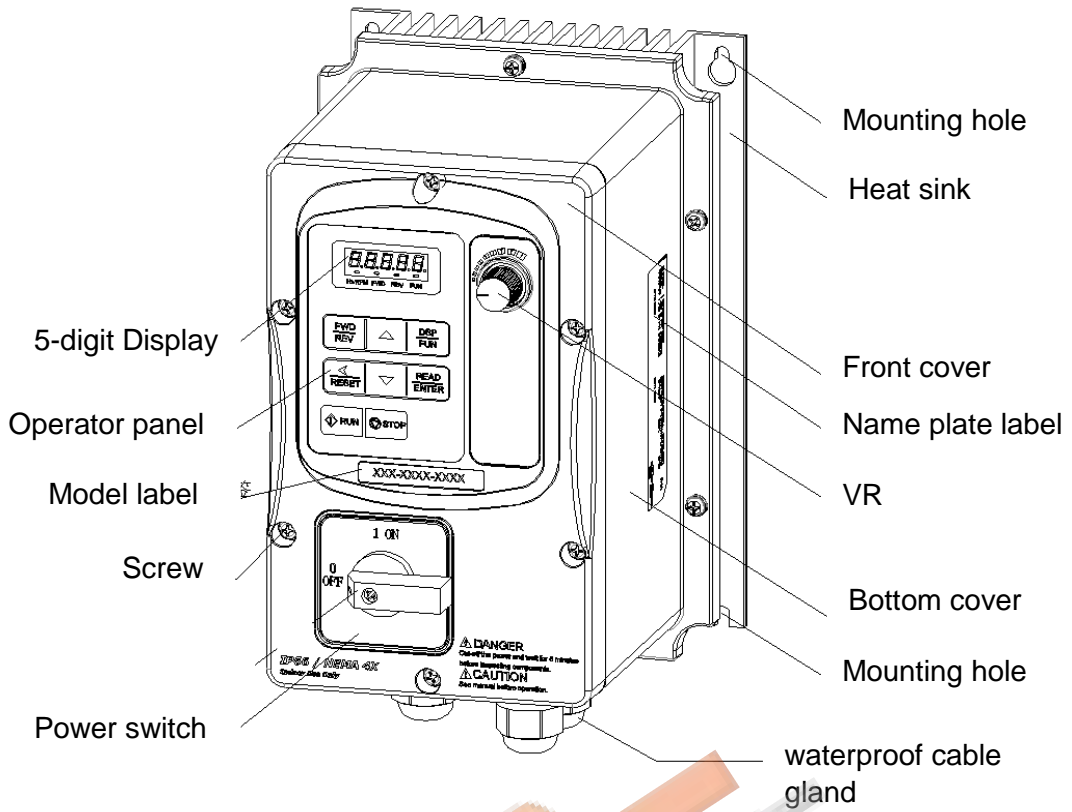

**(b) Single/Three phase : 200V 2~3HP ; Single phase : 200V 2~3HP ; Three phase : 200V5HP ; 400V 3~5HP**

**E510-Frame 2 (IP66/NEMA 4X With/Without VR and switches depending on the model)**

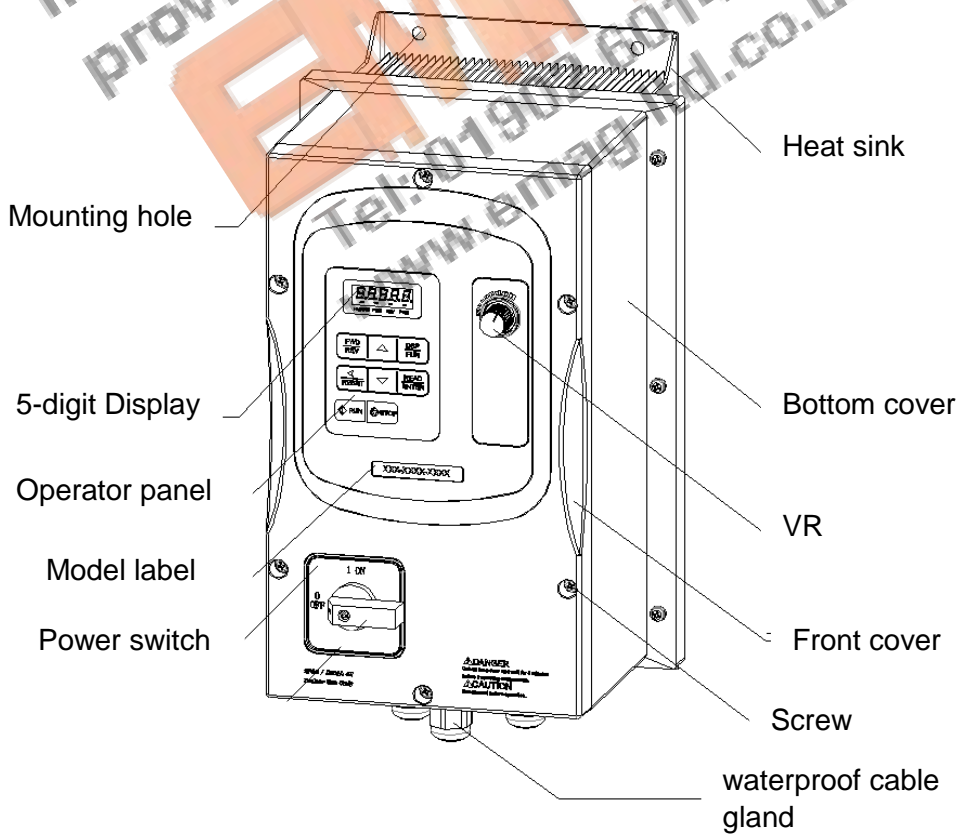

(c) Three phase : 200V 8~20HP ; 400V 8~25HP

**E510-Frame 3 (IP66/NEMA 4X With/Without VR and switches depending on the model)**

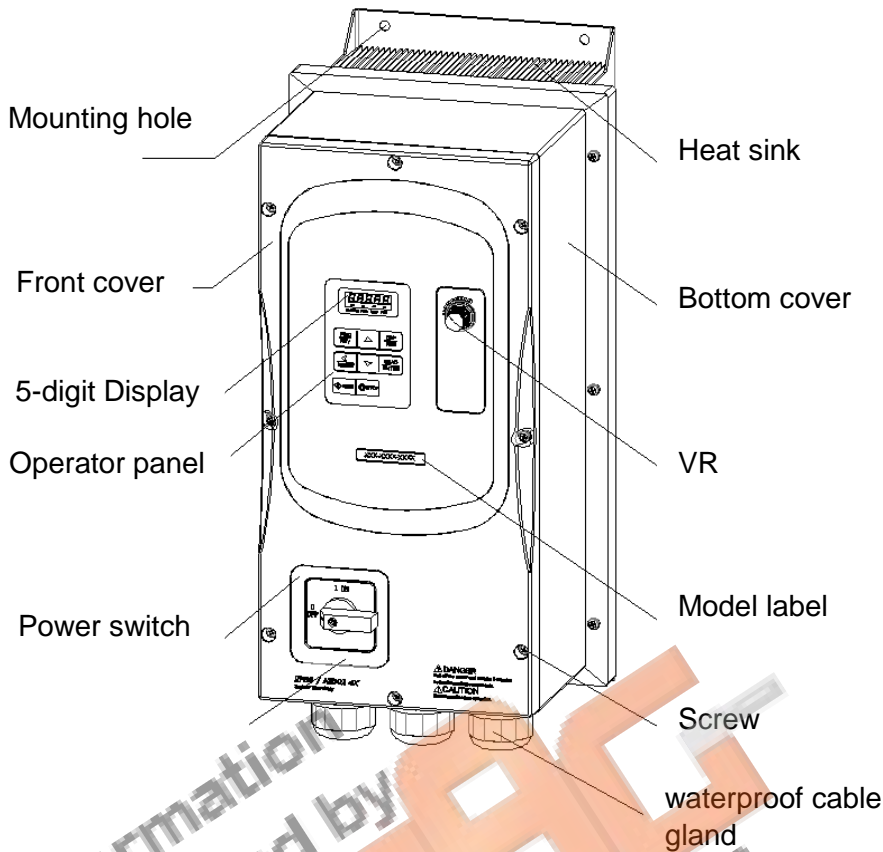

**Interior Layout**

**E510-Frame 1**

**E510-Frame 2**

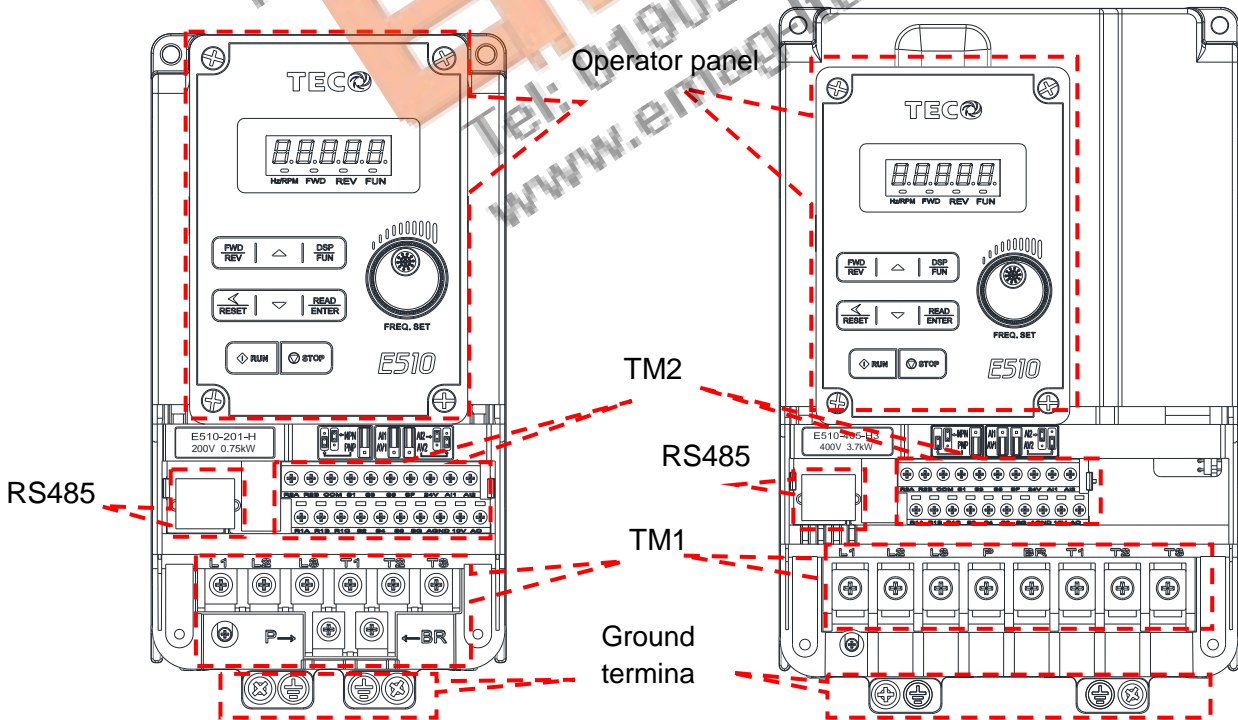

E510-Frame 3

E510-Frame 4

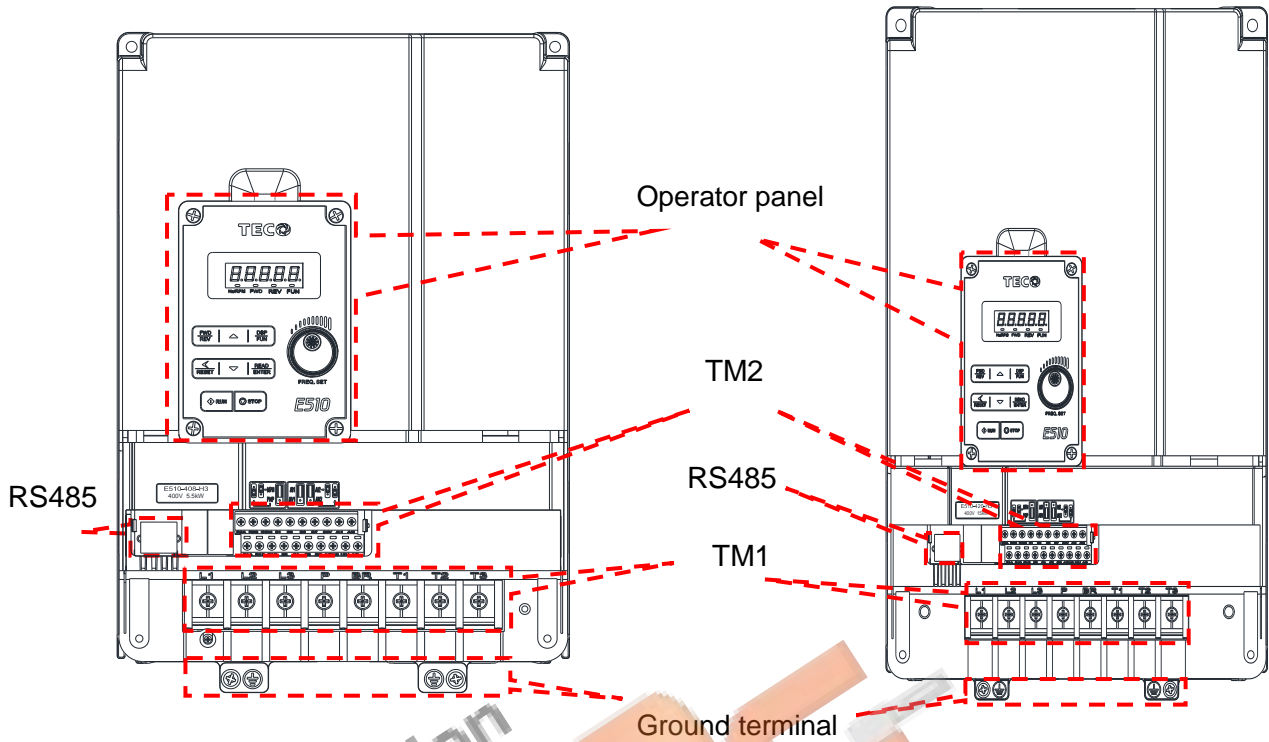

Warning label

Information provided by **EMC**  
 www.emc-td.co.uk

**xPH-xxxV-xkW**

**⚠ DANGER / DANGER**  
 Cut-off the power and wait for 5 minutes before inspecting components.  
 Couper l'alimentation et attendre 5 minutes avant d'inspecter composants.

---

**⚠ CAUTION / ATTENTION**  
 See manual before operation.  
 Consultez le manuel avant l'opération.

**⚠ WARNING / AVERTISSEMENT**  
 Hot surface risk of burn  
 Risque de brûlure de surface chaude

## 3.4 Specifications

### 3.4.1 Product Specifications

#### 200V Class:Single phase

Model: E510-□□□- H1F(N4)(S)	2P5	201	202	203
Horse power (HP)	0.5	1	2	3
Suitable motor capacity (KW)	0.4	0.75	1.5	2.2
Rated output current (A)	3.1	4.5	7.5	10.5
Rated capacity (KVA)	1.2	1.7	2.90	4.00
Input voltage range(V)	Single Phase:200~240V,50/60HZ			
Allowable voltage fluctuation	+10%-15%			
Output voltage range(V)	Three phase: 0~240V			
Input current (A)*	8.5	12	16	23.9
Inverter net weight (KG)	1.65	1.65	2.5	2.5
Allowable momentary power loss time (S)	2.0	2.0	2.0	2.0
Enclosure	IP20/NEMA1&IP66/NEMA4X			

#### 200V Class:Single/Three phase

Model: E510-□□□- H(N4R)	2P5	201	202	203
Horse power (HP)	0.5	1	2	3
Suitable motor capacity (KW)	0.4	0.75	1.5	2.2
Rated output current (A)	3.1	4.5	7.5	10.5
Rated capacity (KVA)	1.2	1.7	2.90	4.00
Input voltage range(V)	Single/Three Phase:200~240V, 50/60HZ			
Allowable voltage fluctuation	+10%-15%			
Output voltage range(V)	Three phase: 0~240V			
Input current (A)*	8.5/4.5	12/6.5	16/11	23.9/12.5
Inverter net weight (KG)	1.6	1.6	2.5	2.5
Allowable momentary power loss time (S)	2.0	2.0	2.0	2.0
Enclosure	IP20/NEMA1&IP66/NEMA4X			

#### 200V Class:Three phase

Model: E510-□□□- H3(N4)	202	205	208	210	215	220
Horse power (HP)	2	5	7.5	10	15	20
Suitable motor capacity (KW)	1.5	3.7	5.5	7.5	11	15
Rated output current (A)	7.5	17.5	26	35	48	64
Rated capacity (KVA)	2.9	6.7	9.9	13.3	20.6	27.4
Input voltage range(V)	Three phase :200~240V,50/60HZ					
Allowable voltage fluctuation	+10%-15%					
Output voltage range(V)	Three phase: 0~240V					
Input current (A)*	11	20.5	33	42	57	70
Inverter net weight (KG)	1.6	2.5	6.5	6.5	10.1	10.4
Allowable momentary power loss time (S)	2.0	2.0	2.0	2.0	2.0	2.0
Enclosure	IP20/NEMA1&IP66/NEMA4X					

\*The input current is calculated value at full rated output current.

### 400V Class: Three phase

Model: E510-□□□- H3(F)(N4)(S)	401	402	403	405
Horse power (HP)	1	2	3	5
Suitable motor capacity (KW)	0.75	1.5	2.2	3.7
Rated output current (A)	2.3	3.8	5.2	8.8
Rated capacity (KVA)	1.7	2.9	4.0	6.7
Input voltage range(V)	Three phase: 380~480V, 50/60HZ			
Allowable voltage fluctuation	+10%-15%			
Output voltage range(V)	Three phase: 0~480V			
Input current (A)*	4.2	5.6	7.3	11.6
Inverter net weight (KG)	1.7	1.7	2.5	2.5
Allowable momentary power loss time (S)	2.0	2.0	2.0	2.0
Enclosure	IP20/NEMA1&IP66/NEMA4X			

Model: E510-□□□- H3(F)(N4)	408	410	415	420	425
Horse power (HP)	7.5	10	15	20	25
Suitable motor capacity (KW)	5.5	7.5	11	15	18.5
Rated output current (A)	13.0	17.5	24	32	40
Rated capacity (KVA)	9.9	13.3	19.1	27.4	34
Input voltage range(V)	Three phase: 380~480V, 50/60HZ				
Allowable voltage fluctuation	+10%-15%				
Output voltage range(V)	Three phase: 0~480V				
Input current (A)*	17	23	31	38	48
Inverter net weight (KG)	6.7	6.7	6.7	13.7	13.7
Allowable momentary power loss time (S)	2.0	2.0	2.0	2.0	2.0
Enclosure	IP20/NEMA1&IP66/NEMA4X				

\*The input current is calculated value at full rated output current.

#### F: Built-in filter

**N4: Protection class IP66, without built-in power switches and VR.**

**N4R: Protection class IP66, with built-in VR, without power switches**

**N4S: Protection class IP66, with built-in power switches and VR**



### 3.4.2 General Specifications

Item		E510
<b>Control Mode</b>		V/F Control, Vector Control
<b>Frequency</b>	Output Frequency	0.01~650.00Hz
	Starting Torque	150%/1Hz(Vector)
	Speed Control Range	1:50
	Setting resolution	Digital input: 0.01Hz
		Analog input:0.06Hz/60Hz
	Setting	Keypad:Set directly with ▲ ▼ keys or the VR on the keypad
External Input Terminlas: AI1(0/2~10V), AI2(0/4~20mA)input Multifunction input up/down function(Group3) Setting frequency by communication method.		
Frequency limit	Lower and upper frequency limits 3 skip frequency settings.	
<b>Run</b>	Operation set	Keypad run, stop button
		External terminals: Multi- operation-mode2 / 3 wire selection Jog operation
		Run signal by communication method.
<b>Main Control Features</b>	V / F curve setting	18 fixed curves and one customized curve
	Carrier frequency	1~16KHz
	Acceleration and deceleration control	2 off Acc / dec time parameters. 4 off S curve parameters.
	Multifunction input	29 functions (refer to description on group3)
	Multifunction output	21 functions (refer to description on group3)
	Multifunction analog output	5 functions (refer to description on group4)
Main features	Overload Detection,16 preset speeds,Auto-run,Acc/Dec Switch (2 Stages),Main/Alt run Command select,Main/Alt Frequency Command select,PID control, torque boost, V/F start Frequency, Fault reset, Firemode.	
<b>Display</b>	LED	Display :parameter / parameter value / frequency / line speed / DC voltage / output voltage / output current / PID feedback / input and output terminal status / Heat sink temperature / Program Version / Fault Log.
	LED Status Indicator	Run / Stop / Forward / Reverse ,and etc.
<b>Protective Functions</b>	Overload Protection	The relays to protect the motor and the inverter. (150%/1min)
	Over voltage	.220V: >410V ,380V: >820V
	Under Voltage	.220V: <190V , 380V: <380V
	Momentary Power Loss Restart	Inverter auto-restart after a momentary power loss.
	Stall Prevention	Stall prevention for Acceleration/ Deceleration/ Operation.
	Short-circuit output terminal	Electronic Circuit Protection
	Grounding Fault	Electronic Circuit Protection
	Other protection features	Protection for overheating of heat sink,The carrier frequency decreasing with the temperature function,fault output,reverse prohibit,prohibit for direct start after power up and error recovery ,parameter lock up
All frames include brake transistor		

<b>Communication control</b>		Standard built-in RS485 communication (Modbus), One to one or One to many control.
<b>Environment</b>	Operating temperature	-10~50°C (Note1)
	Storage temperature	-20~60°C
	Humidity	95% RH or less (no condensation) (Compliance with IEC 60068 - 2-78)
	Shock	20Hz or less 1G(9.8m/s <sup>2</sup> )20~50Hz 0.6G(5.88m/s <sup>2</sup> ) (Compliance with IEC 60068 - 2-6)
	Enclosure	<b>IP20/NEMA1&amp;IP66/NEMA4X</b>

Note1:

IP20/NEMA 1 Type:

-10 ~ 50°C (without stick on type dust cover.)

-10 ~40°C (with stick on type dust cover.)

IP66/NEMA 4X Type :

-10~50°C

Information  
provided by  
**EMAG**  
Tel: 01902 601403  
[www.emag-ltd.co.uk](http://www.emag-ltd.co.uk)

# 3.5 Standard wiring

## 3.5.1 Single phase

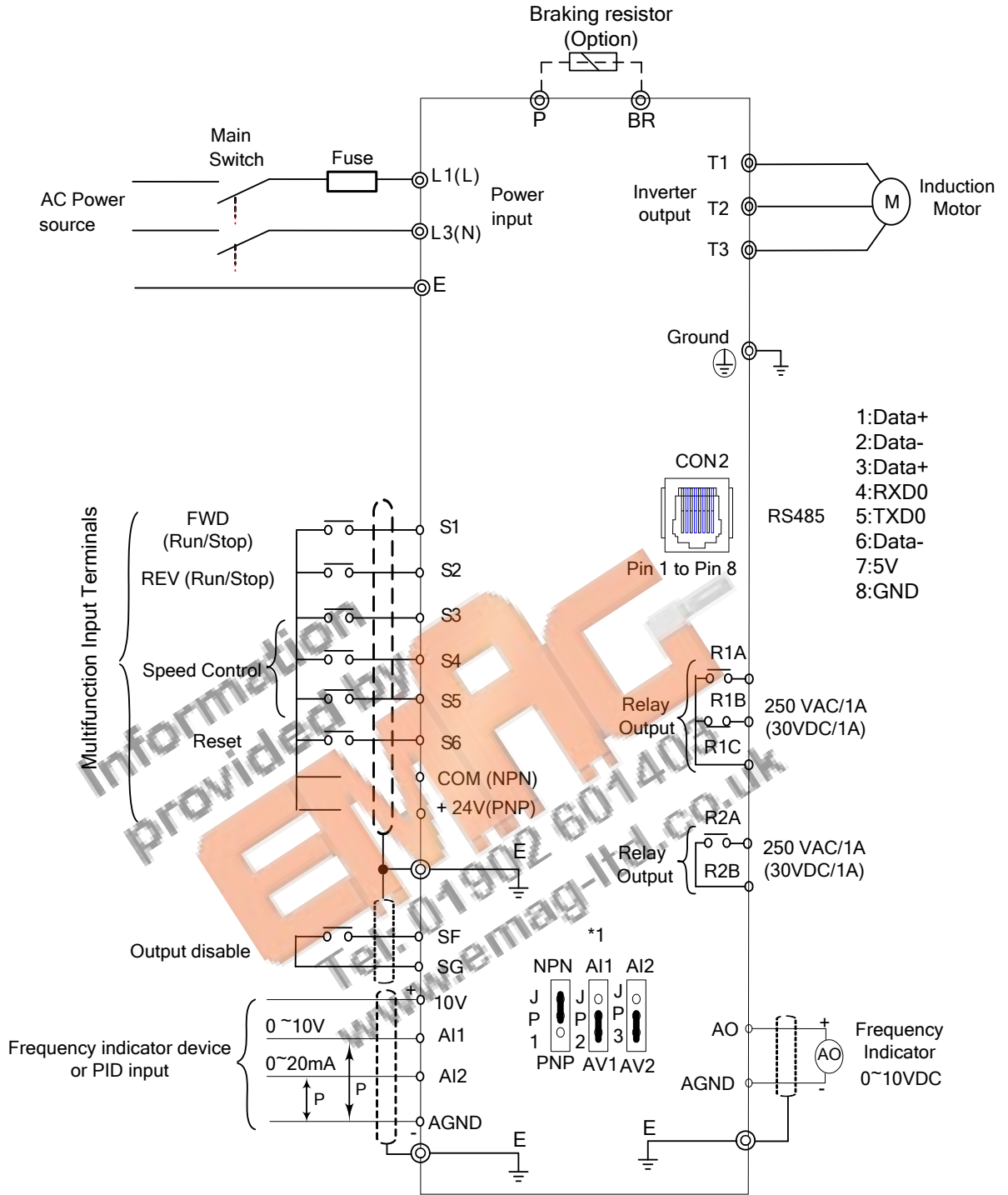

Ⓜ Indicates shield wire ⓂP Indicates twisted-pair shield wire

⊙ Shows main circuit ○ Shows control circuit

\*1: JP1:NPN/PNP selection, JP2:AI1 0~10V/0~20mA selection, JP3:AI2 0~10V/0~20mA selection

### Model:

200V: E510-2P5-H1(F)(N4S) /E510-201-H1(F)(N4S)/ E510-202-H1(F)(N4S) /E510-203-H1(F)(N4S)

### 3.5.2 Single /Three phase

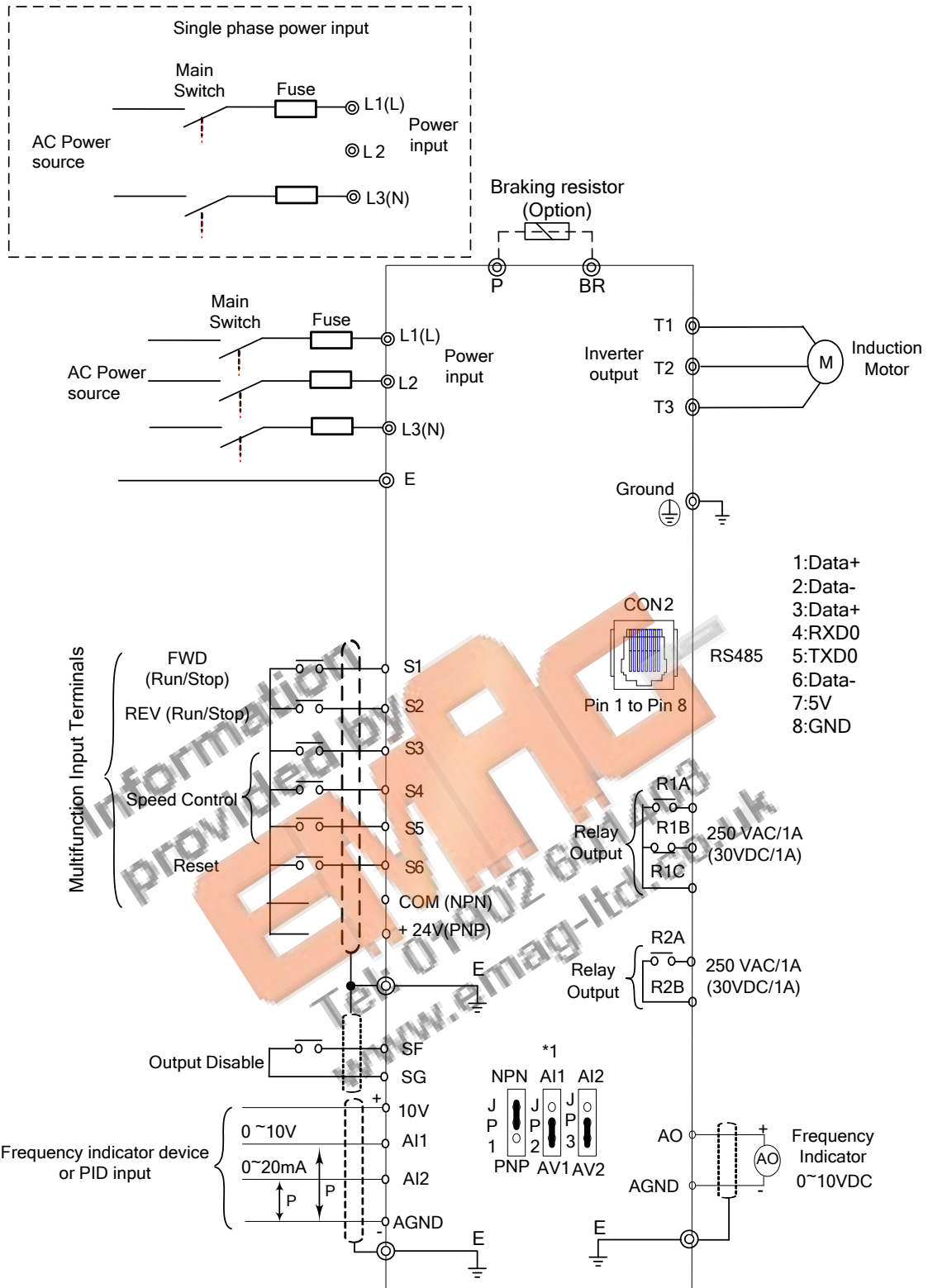

Indicates shield wire   
 P Indicates twisted-pair shield wire  
 Shows main circuit   
 Shows control circuit

\*1: JP1:NPN/PNP selection, JP2:AI1 0~10V/0~20mA selection, JP3:AI2 0~10V/0~20mA selection

**Model:**

**200V: E510-2P5-H(N4R)/ E510-201-H(N4R)/ E510-202-H(N4R)/ E510-203-H(N4R)**

### 3.5.3 Three phase

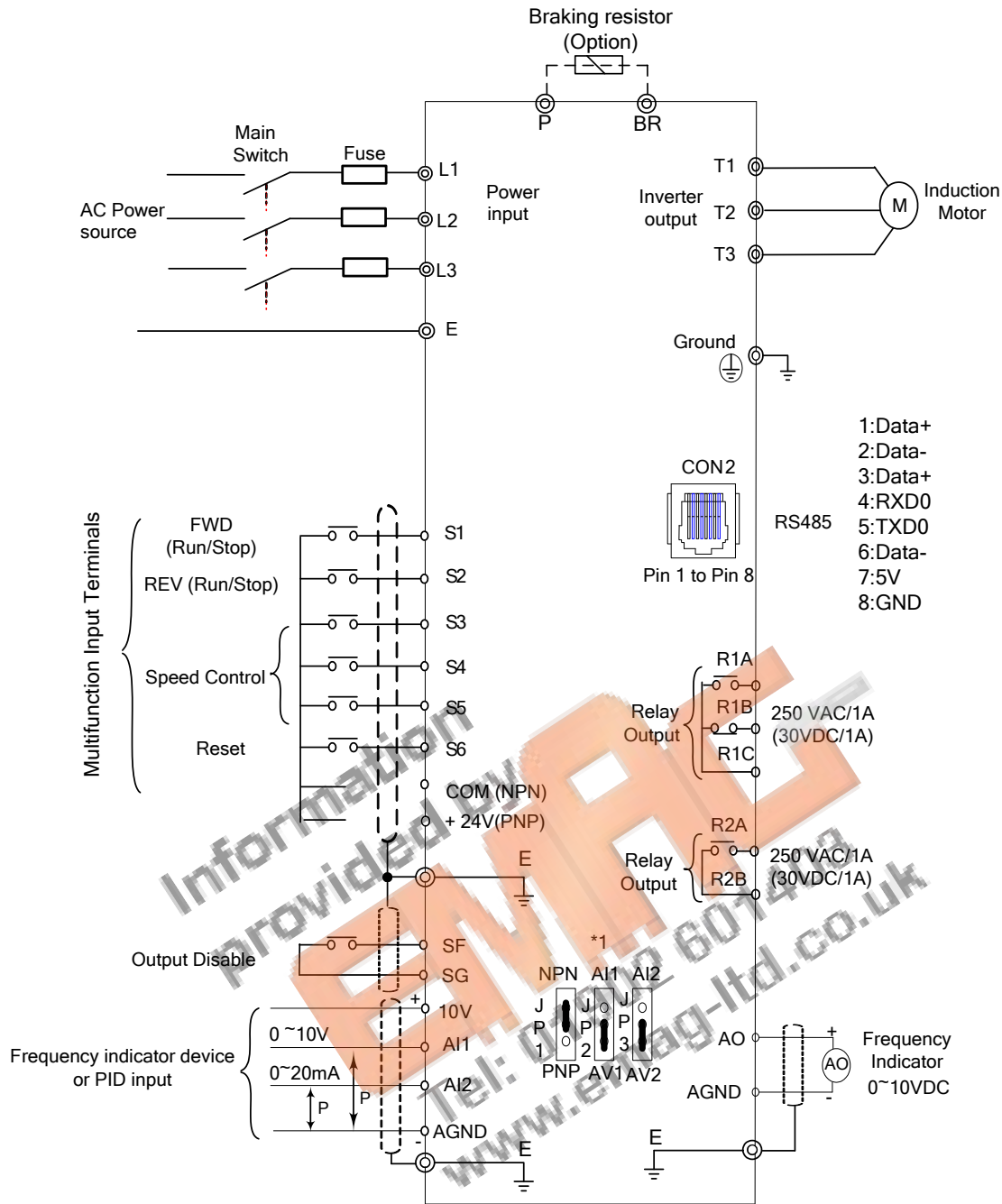

Indicates shield wire   
 P Indicates twisted-pair shield wire  
 Shows main circuit   
 Shows control circuit

\*1: JP1:NPN/PNP selection, JP2:AI1 0~10V/0~20mA selection, JP3:AI2 0~10V/0~20mA selection

#### Model:

**200V:** E510-202-H3(N4)/E510-205-H3(N4)/E510-208-H3(N4)/E510-210-H3(N4)/  
 E510-215-H3(N4)/E510-220-H3(N4)

**400V:** E510-401-H3(F)(N4)(S)/ E510-402-H3(F)(N4)(S)/ E510-403-H3(F)(N4)(S)/ E510-405-H3(F)(N4)(S)/  
 E510-408-H3(F)(N4)(S)/ E510-410-H3(F)(N4)(S)/ E510-415-H3(F)(N4)(S)/ E510-420-H3(F)(N4)(S)/  
 E510-425-H3(F)(N4)(S)



## 3.6 Terminal Description

### 3.6.1 Description of main circuit terminals

Terminal symbols	TM1 Function Description
L1(L)	Main power input: Single phase: L1(L)/L3(N) Single/Three phase:L1(L)/L2/L3(N) Three phase:L1/L2/L3
L2	
L3(N)	
T1	Inverter output, connect to U/V/W terminals of motor
T2	
T3	
P	Braking resistor connection terminal: Used in applications when it is required to stop a high inertia load rapidly. (refer to specifications of the braking resistor)
BR	
	Ground terminal

#### Frame1

#### Single phase: 200V 0.5~1HP

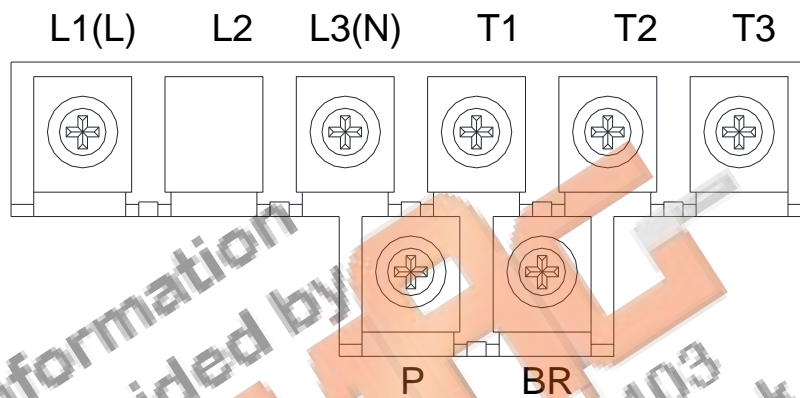

Note: the screw on L2 terminal is removed for the single phase input supply models.

#### Single/Three phase:200V 0.5~1HP; Three phase:200V 2HP; 400V 1~2HP;

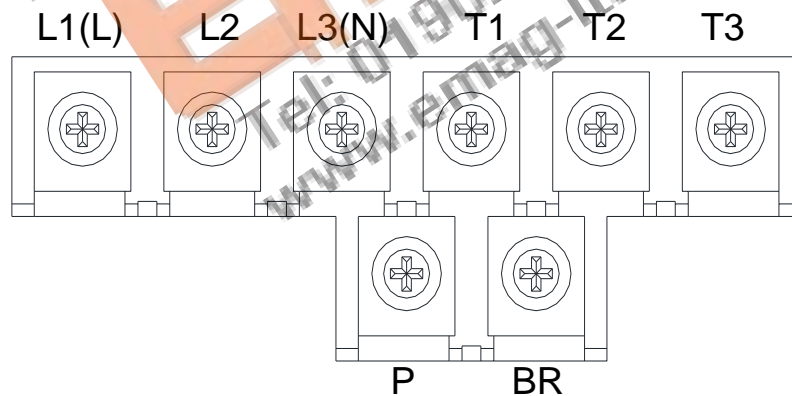

**Frame2**

**Single phase:200V 2~3HP;**

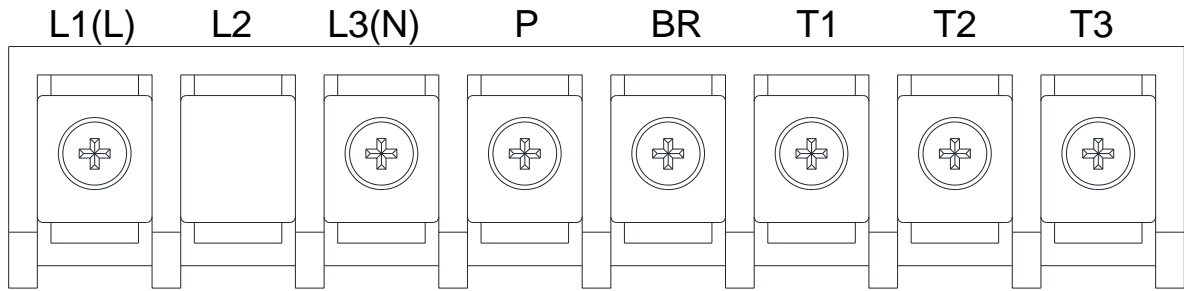

**Single/Three phase:200V 2~3HP; Three phase:200V 5HP; 400V 3~5HP;**

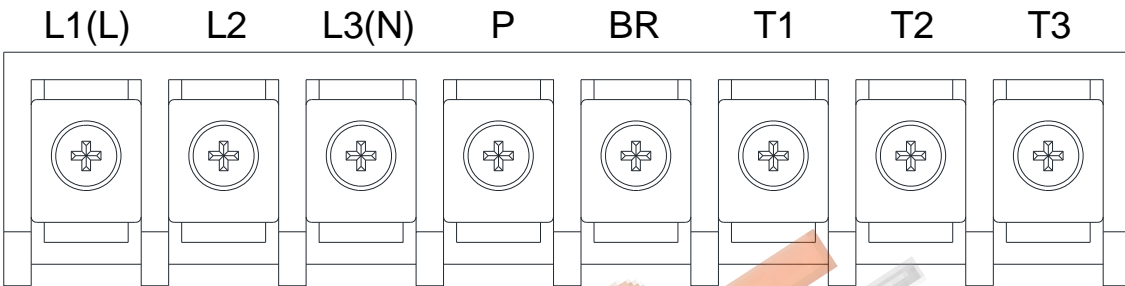

**Frame3 & Frame4**

**Three phase:200V 7.5~20HP; 400V 7.5~25HP**

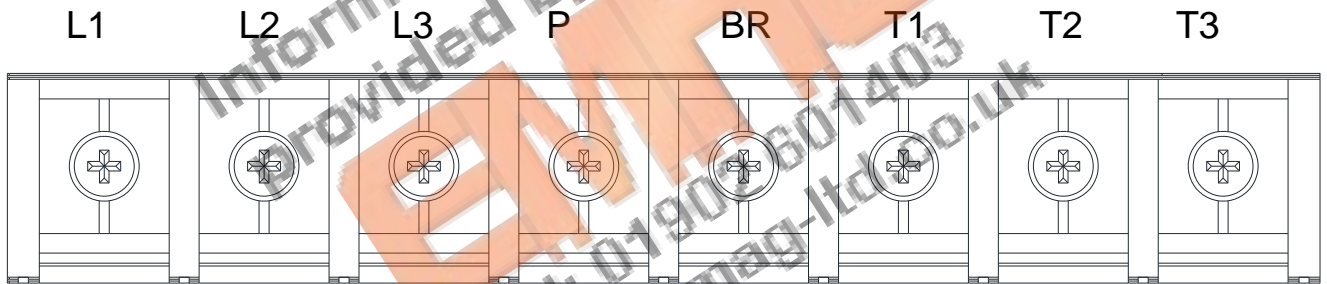

### 3.6.2 Control circuit terminal description

Type	Terminal	Terminal function	Signal level
Digital input signal	S1	Forward—Stop (Preset), Multi function input terminal	24 VDC, 8 mA, Optical coupling isolation(Max,voltage30 Vdc, Input impedance 3.3kΩ)
	S2	Reverse—Stop (Preset), Multi function input terminal	
	S3	Preset Speed0(5-02),Multi function input terminal	
	S4	Preset Speed1(5-03), Multi function input terminal	
	S5	Preset Speed2(5-05), Multi function input terminal	
	S6	Fault reset input, Multi function input terminal	
Relay output	R1A	NO(Normally open)	250VAC/1A(30VDC/1A)
	R1B	NC(Normally closed)	
	R1C	COMMON	
	R2A	Multi function output:Run,Fault,setting Frequency ,Frequency Reached,Auto Restart,Momentary AC Power Loss,Rapid Stop ,Base Block Stop Mode,Motor Overload Protection,Drive Overload Protection,Over-torque Threshold Level. Preset Current level Reached、Preset Brake Frequency Reached,PID Feedback Signal Loss,Final count value reached, Initial count value reached,PLC Status Indicator ,PLC control...	
	R2B		
24V Power supply	COM	Digital signal common terminal (JP1 Switching NPN position)	±15%,Max output current 60mA
	24V	Digital signal common terminal (JP1 Switching PNP position)	
The analog input signal	10V	Built in Power for an external speed potentiometer	10V(Max current:20mA)
	A1	Multifunctional analog input: JP2 selects voltage or current input Voltage: JP2 in AV1 position Current: JP2 in A11 position	0 ~ 10V,(Max current:20mA) (Input impedance: 153KΩ)
	A2	Multifunctional analog input: JP3 selects voltage or current input Voltage: JP3 in AV2 position Current: JP3 in A12 position	0 ~ 10V,0 ~20mA (Input impedance: 153KΩ)
	AGND	The analog common terminal	----
		Shielding wire connecting terminal (The earth)	----
The analog output signal	AO	Multifunctional analog output terminal*3	0 ~10V,(Max current:2mA)
	AGND	The analog common terminal	----
Safety switch	SF	Terminal SF is for output disable	
	SG		

#### Control circuit terminal:

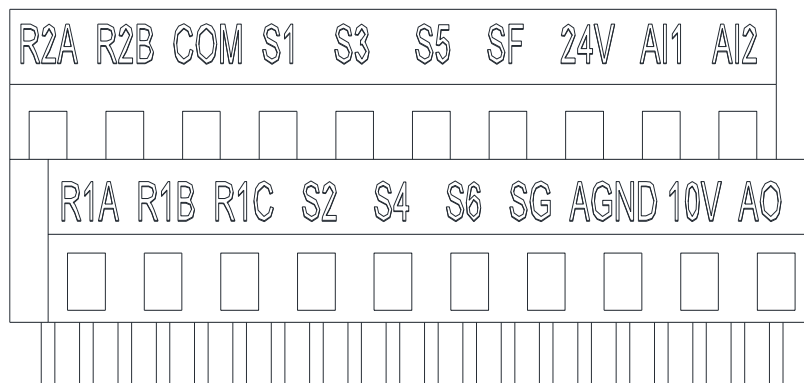

## JUMPER function description

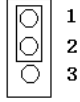
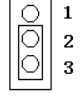
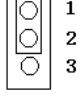
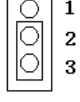
Jumper	Symbol	Function	Signal Reference	Note
JP1	 1 2 3	NPN/PNP selectable	NPN Input	Factory default setting
	 1 2 3		PNP Input	
JP2/JP3	 1 2 3	External signal type selection	0~20mA / 4~20mA Analog signal	Set parameters 00-05/00-06 to 2 or 3 (external analog input) to become effective
	 1 2 3		0~10VDC / 2~10VDC Analog signal	

Information  
provided by  
**EMAG**  
Tel: 01902 601403  
www.emag-ltd.co.uk

### 3.7 Outline Dimensions

mm(inch)

Tolerance Table				
1 ~ 10 ± 0.1 (0.04~0.40 ± 0.004)	10 ~ 50 ± 0.2 (0.40~1.97 ± 0.01)	50 ~ 100 ± 0.3 (1.97~4 ± 0.01)	100 ~ 200 ± 0.5 (4~7.87 ± 0.02)	200 ~ 400 ± 0.8 (7.87~15.75 ± 0.03)

#### 3.7.1 IP20/NEMA1 dimensions

Frame1 (IP20)

Single/Three phase: 200V 0.5~1HP ; Single phase: 200V 0.5~1HP

Three phase: 200V 2HP; 400V 1~2HP

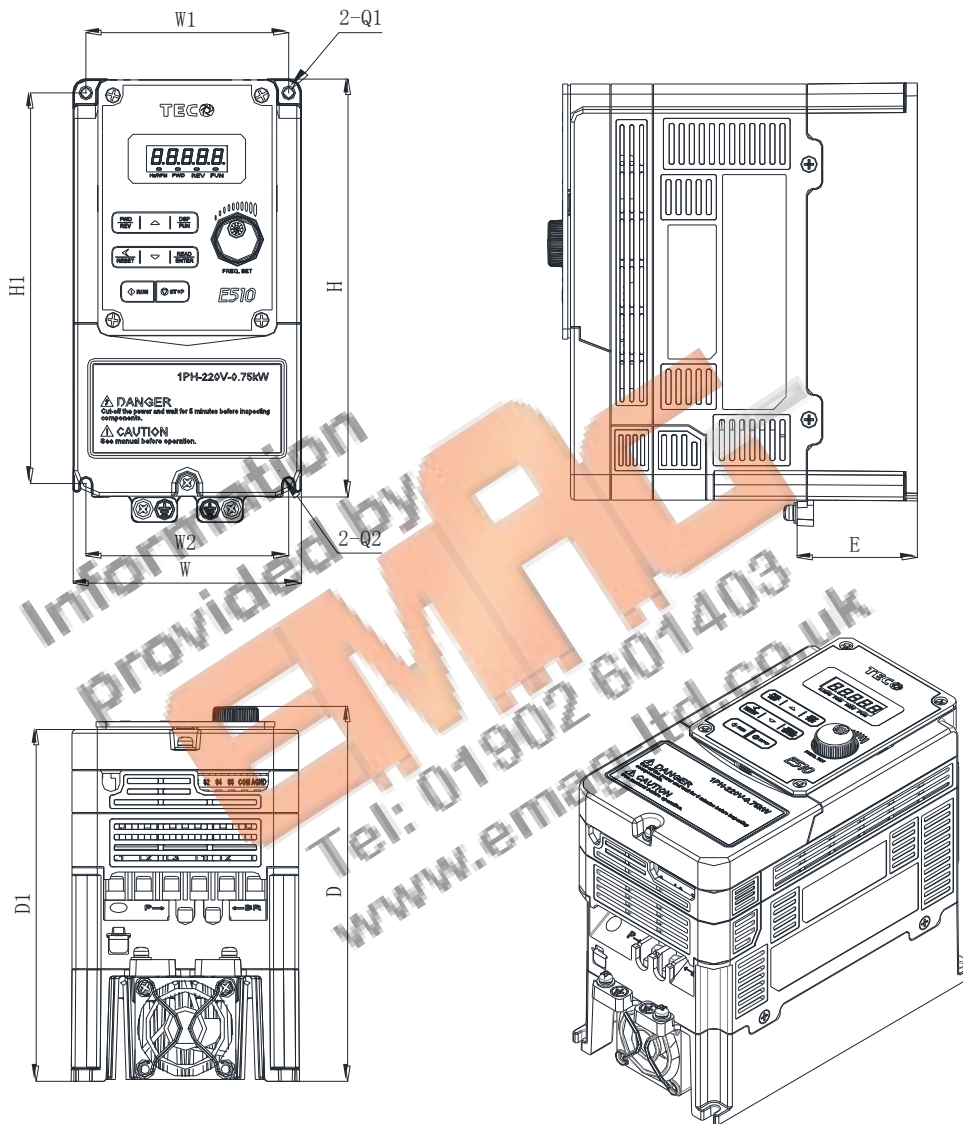

Unit: mm(inch)

Model	Dimensions										N.W (Kg)
	W	W1	W2	H	H1	D	D1	E	Q1	Q2	
E510-2P5-H											1.6
E510-201-H											1.6
E510-2P5-H1F											1.7
E510-201-H1F											1.7
E510-202-H3	90.6 (3.57)	81 (3.19)	81 (3.19)	163.6 (6.44)	153 (6.02)	149 (5.87)	141 (5.55)	48 (1.89)	4.3 (0.17)	4.3 (0.17)	1.7
E510-401-H3											1.7
E510-402-H3											1.7
E510-401-H3F											1.7
E510-402-H3F											1.7



**Frame2 (IP20)**

**Single/Three phase: 200V 2~3HP ; Single phase: 200V 2~3HP**

**Three phase: 200V 5HP; 400V 3~5HP**

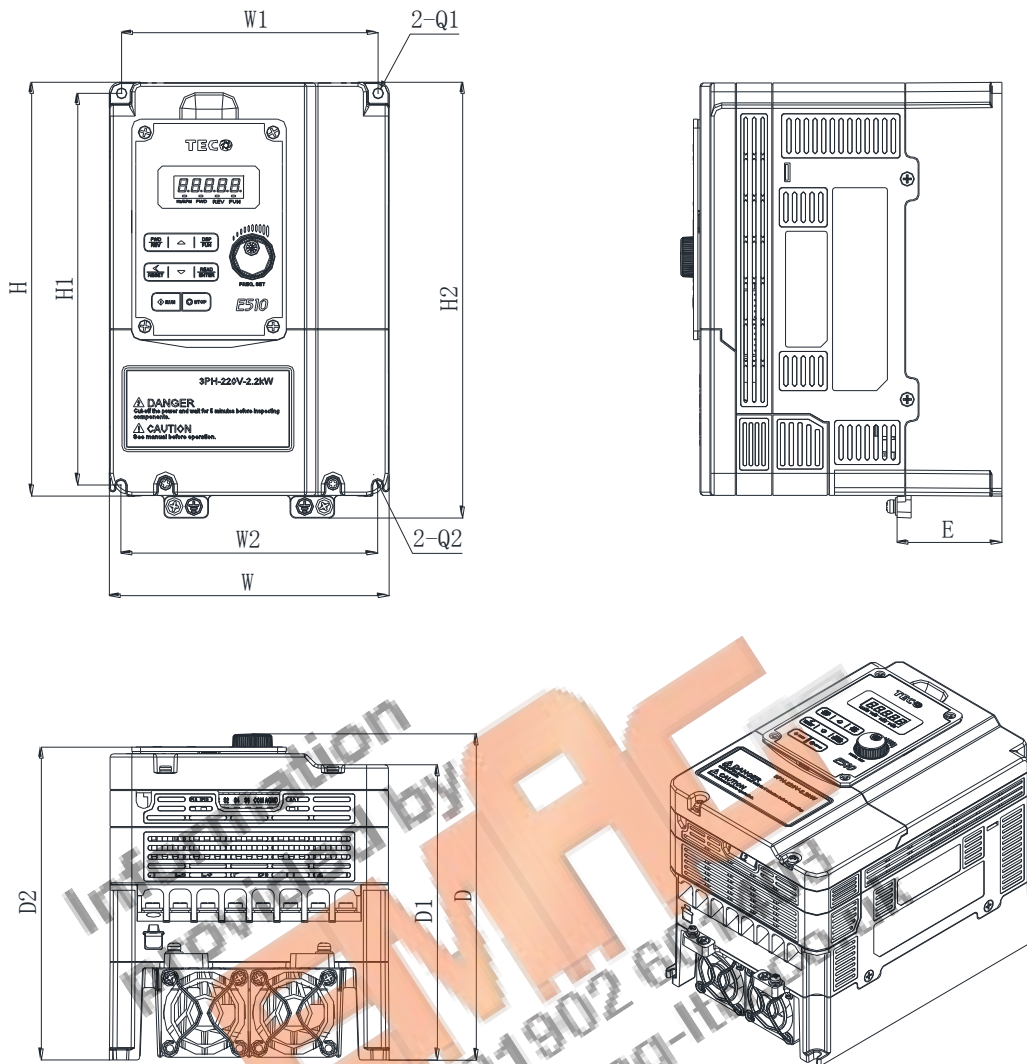

Unit: mm(inch)

Model	Dimensions												N.W (Kg)
	W	W1	W2	H	H1	H2	D	D1	D2	E	Q1	Q2	
E510-202-H													2.5
E510-203-H													2.5
E510-202-H1F													2.5
E510-203-H1F													2.5
E510-205-H3	128.7 (5.07)	118 (4.65)	118 (4.65)	187.6 (7.39)	177.6 (6.99)	197.5 (7.78)	149 (5.87)	133.8 (5.27)	141.8 (5.58)	48.2 (1.9)	4.5 (0.18)	4.5 (0.18)	2.5
E510-403-H3													2.5
E510-405-H3													2.5
E510-403-H3F													2.5
E510-405-H3F													2.5

**Frame3 (IP20)**

**Three phase: 200V 7.5~10HP; 400V 7.5~15HP**

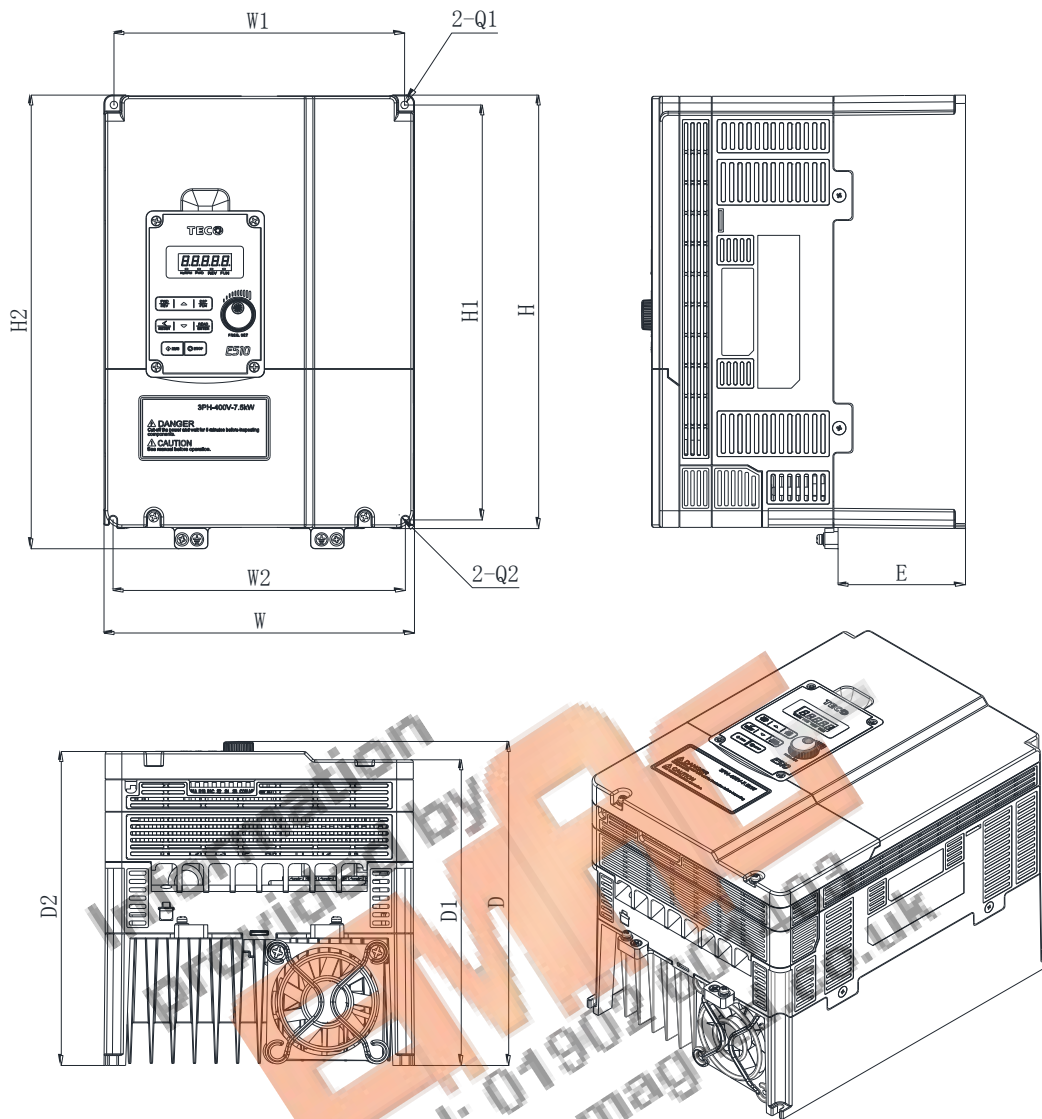

**Unit: mm(inch)**

Model	Dimensions											N.W (Kg)	
	W	W1	W2	H	H1	H2	D	D1	D2	E	Q1		Q2
E510-208-H3													6.5
E510-210-H3													6.5
E510-408-H3													6.5
E510-410-H3	186.9	176	175	260.9	249.8	273	197	184	189	84.7	4.5	4.5	6.5
E510-415-H3	(7.36)	(6.92)	(6.89)	(10.27)	(9.83)	(10.75)	(7.76)	(7.24)	(7.44)	(3.33)	(0.18)	(0.18)	6.5
E510-408-H3F													6.7
E510-410-H3F													6.7
E510-415-H3F													6.7

**Frame4 (IP20)**

**Three phase: 200V 15~20HP; 400V 20~25HP**

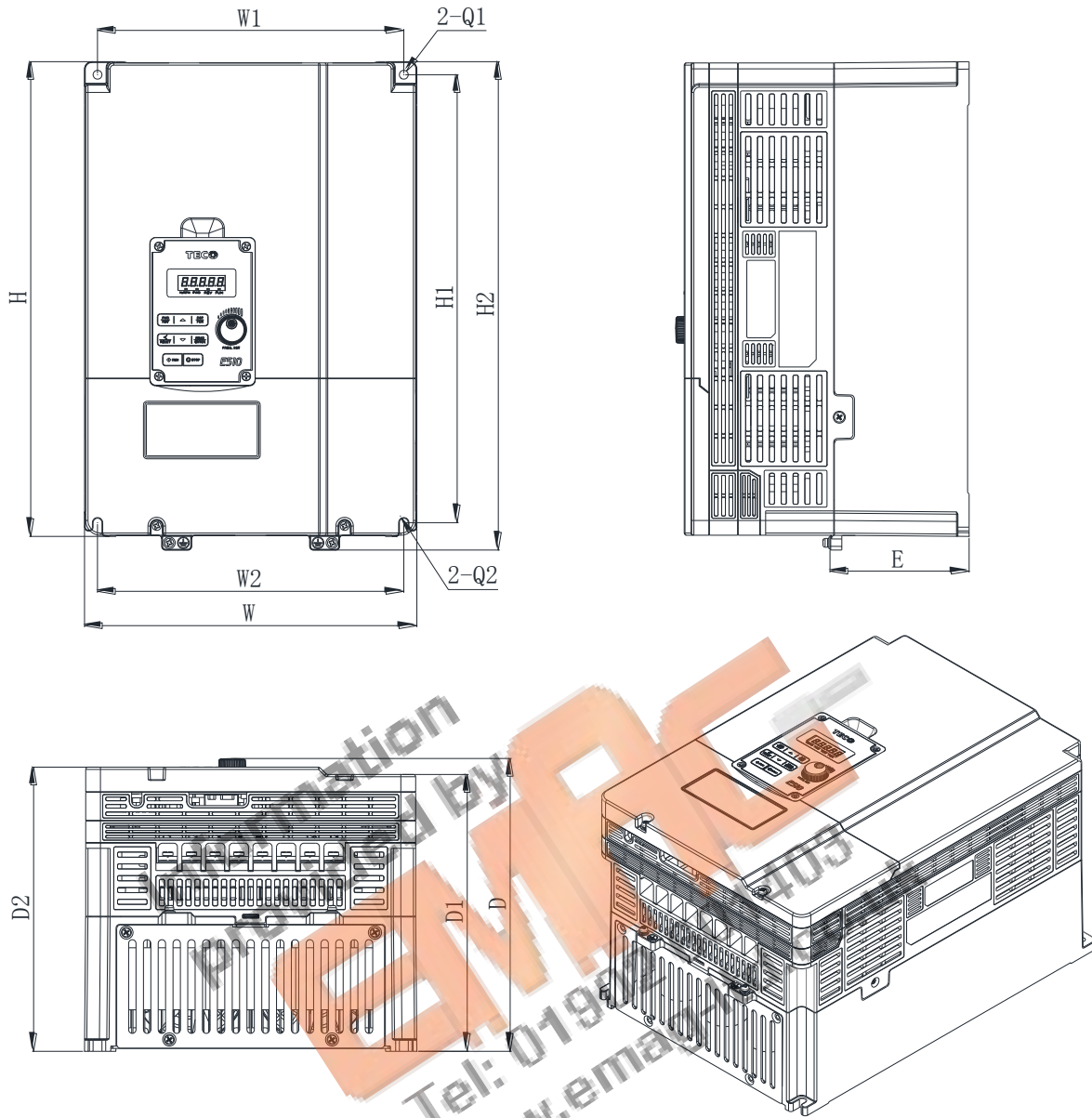

**Unit: mm(inch)**

Model	Dimensions												N.W (Kg)
	W	W1	W2	H	H1	H2	D	D1	D2	E	Q1	Q2	
E510-215-H3													10.1
E510-220-H3	224.6	207	207	321.6	303.5	330.9	200.5	187.5	192.5	94	6	6	10.4
E510-420-H3	(8.84)	(8.15)	(8.15)	(12.66)	(11.95)	(13.03)	(7.9)	(7.38)	(7.58)	(3.7)	(0.24)	(0.24)	10.5
E510-425-H3													10.5

**Frame4 (IP20) (With Filter)**  
**Three phase: 400V 20~25HP**

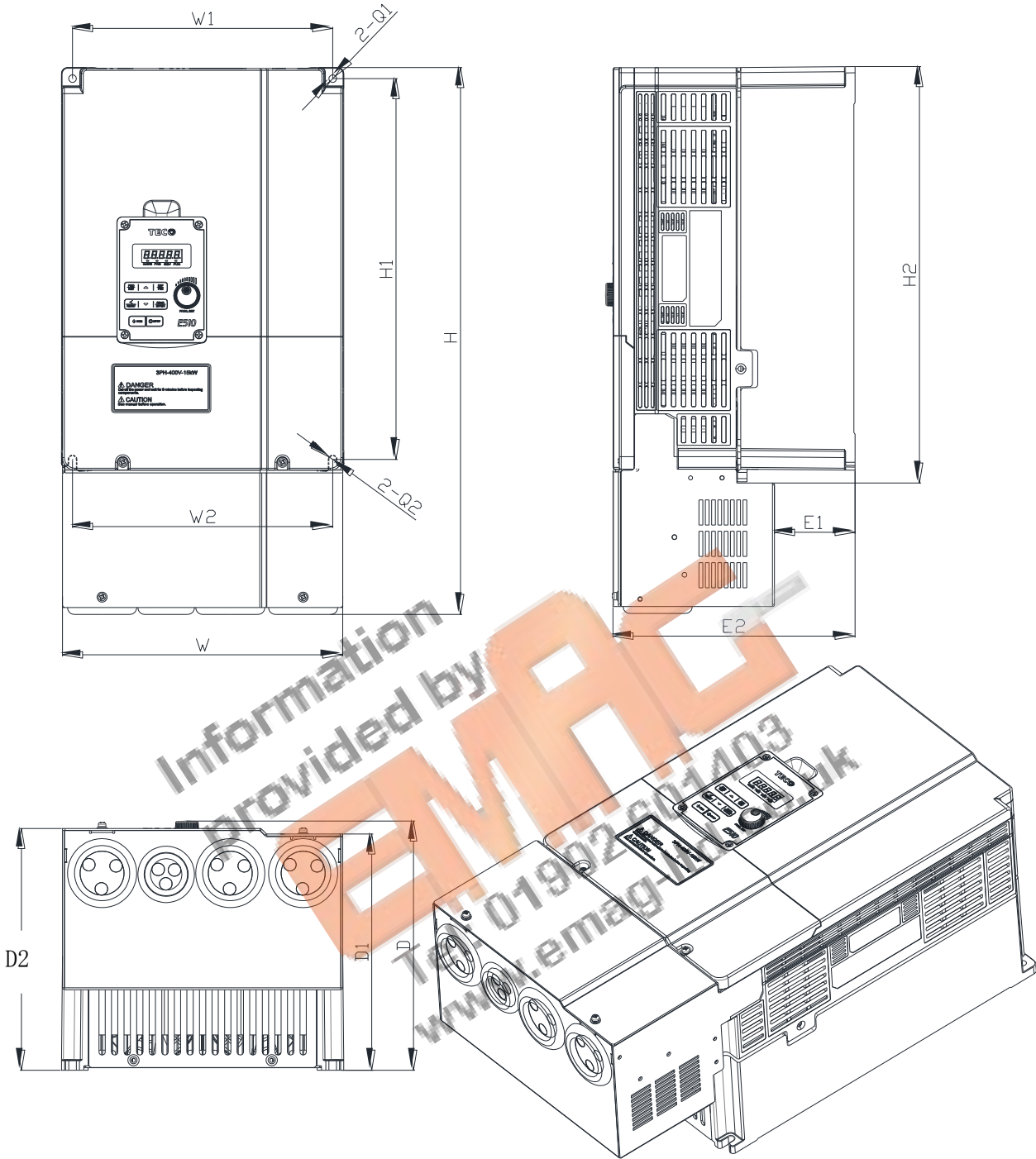

Unit: mm(inch)

Model	Dimensions												N.W (Kg)	
	W	W1	W2	H	H1	H2	D	D1	D2	E1	E2	Q1		Q2
E510-420-H3F	224.6	207	207	435.8	303.5	330.9	200.5	187.5	192.5	64.2	192.5	6	6	13.7
E510-425-H3F	(8.84)	(8.15)	(8.15)	(17.16)	(11.95)	(13.03)	(7.9)	(7.38)	(7.58)	(2.53)	(7.58)	(0.24)	(0.24)	13.7

**Frame1 (NEMA1)**

**Single/Three phase: 200V 0.5~1HP; Single: 200V 0.5~1HP**

**Three phase: 200V 2HP; 400V 1~2HP**

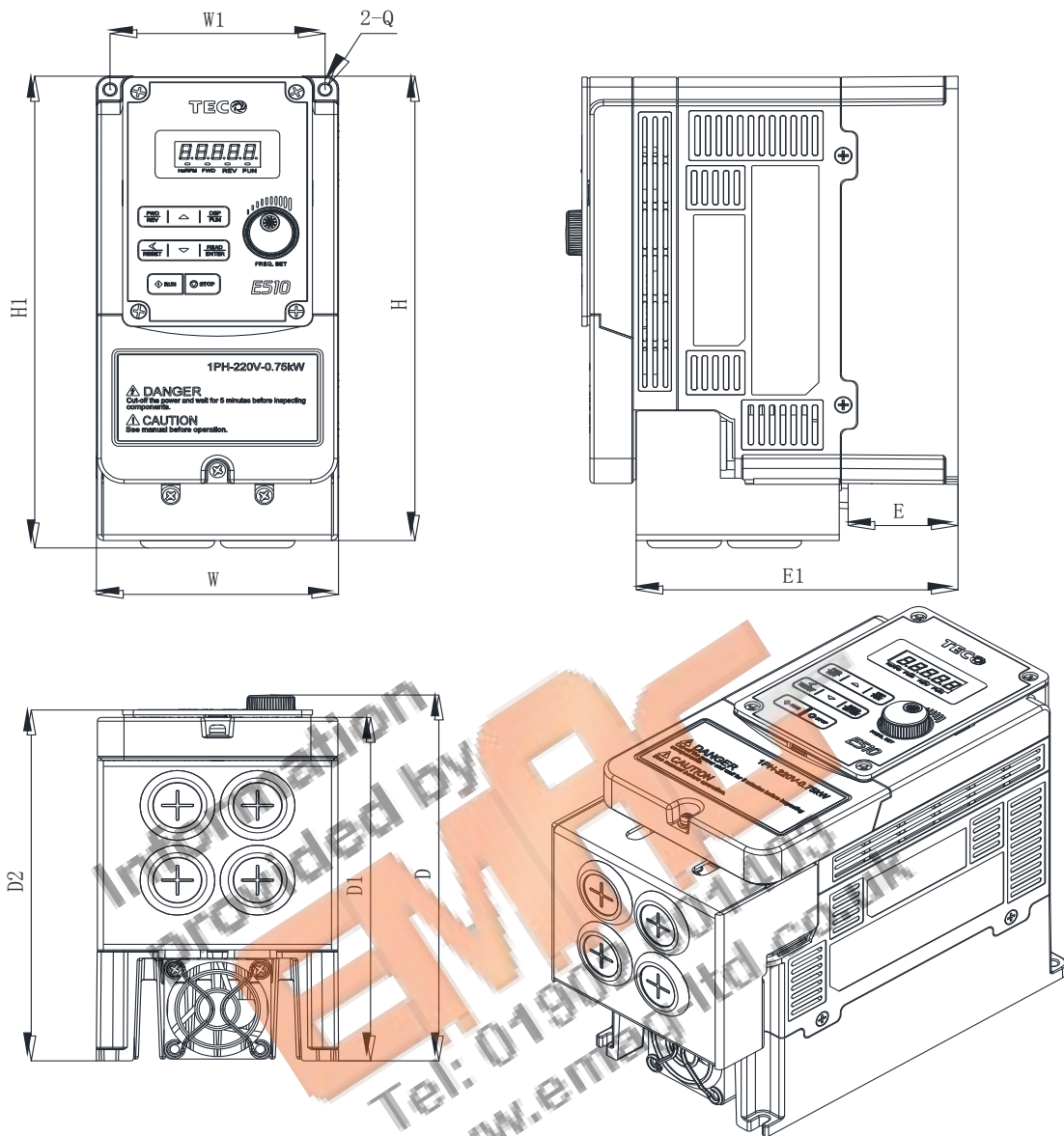

**Unit: mm(inch)**

Model	Dimensions										N.W (Kg)
	W	W1	H	H1	D	D1	D2	E	E1	Q	
E510-2P5-H											1.8
E510-201-H											1.8
E510-2P5-H1F											1.9
E510-201-H1F											1.9
E510-202-H3	90.6	80.5	186.2	189.2	149	137.8	141	41.2	120.5	4.33	1.9
E510-401-H3	(3.57)	(3.17)	(7.33)	(7.45)	(5.87)	(5.42)	(5.55)	(1.62)	(4.74)	(0.17)	1.9
E510-402-H3											1.9
E510-401-H3F											1.9
E510-402-H3F											1.9



**Frame2 (NEMA1)**

**Single/Three phase: 200V 2~3HP; Single: 200V 2~3HP**

**Three phase: 200V 5HP; 400V 3~5HP**

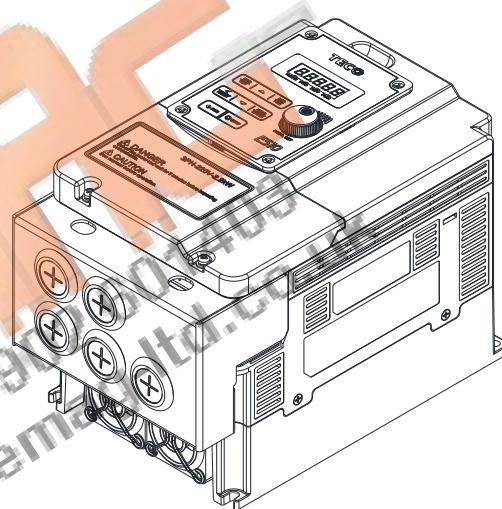
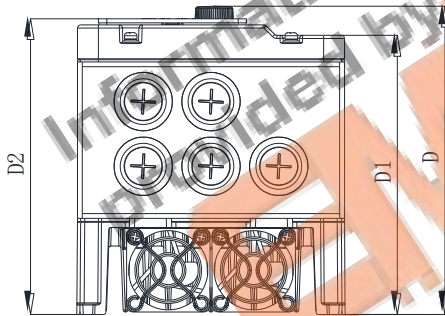
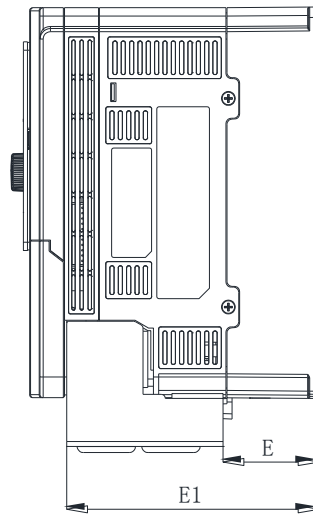
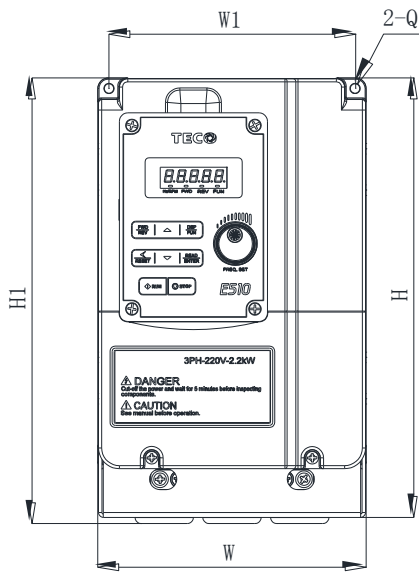

Information provided by: [www.emat.com](http://www.emat.com)  
Tel: 0199000000

Unit: mm(inch)

Model	Dimensions										N.W (Kg)
	W	W1	H	H1	D	D1	D2	E	E1	Q	
E510-202-H	128.7 (5.06)	118 (4.65)	210.6 (8.29)	213.6 (8.41)	149 (5.87)	133.8 (5.27)	141.8 (5.58)	46.1 (1.81)	121.1 (4.77)	4.5 (0.18)	2.7
E510-203-H											2.7
E510-202-H1F											2.8
E510-203-H1F											2.8
E510-205-H3											2.8
E510-403-H3											2.8
E510-405-H3											2.8
E510-403-H3F											2.8
E510-405-H3F											2.8

**Frame3 (NEMA1)**

**Three phase: 200V 7.5~10HP; 400V 7.5~15HP**

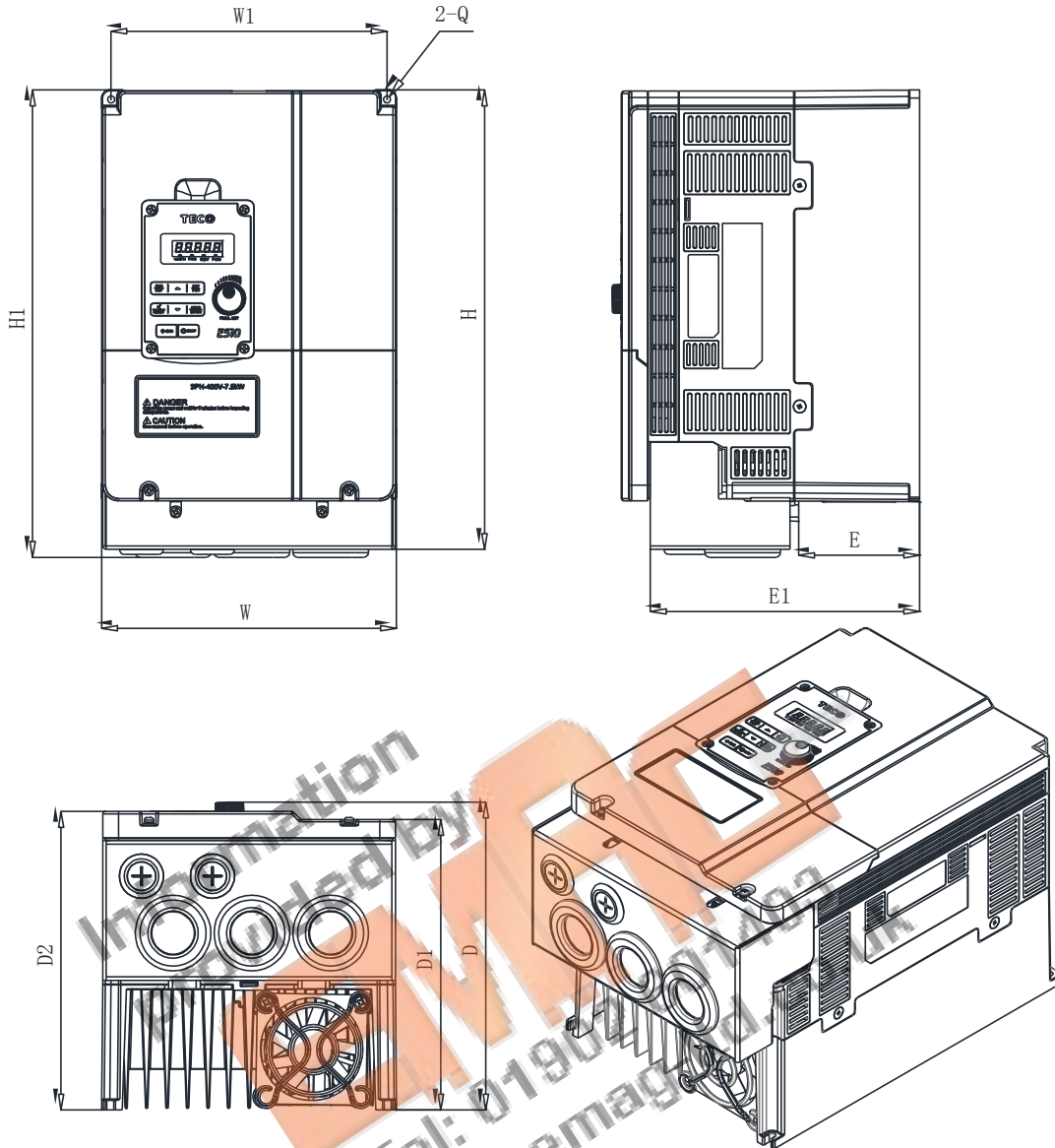

**Unit: mm(inch)**

Model	Dimensions										N.W (Kg)	
	W	W1	H	H1	D	D1	D2	E	E1	Q		
E510-208-H3												6.9
E510-210-H3												6.9
E510-408-H3												6.9
E510-410-H3	187.5	175	291	296	197	184	189	76.7	170.6	4.5	6.9	
E510-415-H3	(7.38)	(6.89)	(11.47)	(11.65)	(7.76)	(7.24)	(7.44)	(3.02)	(6.72)	(0.17)	6.9	
E510-408-H3F												7.1
E510-410-H3F												7.1
E510-415-H3F												7.1

**Frame4 (NEMA1)**

**Three phase: 200V 15~20HP; 400V 20~25HP**

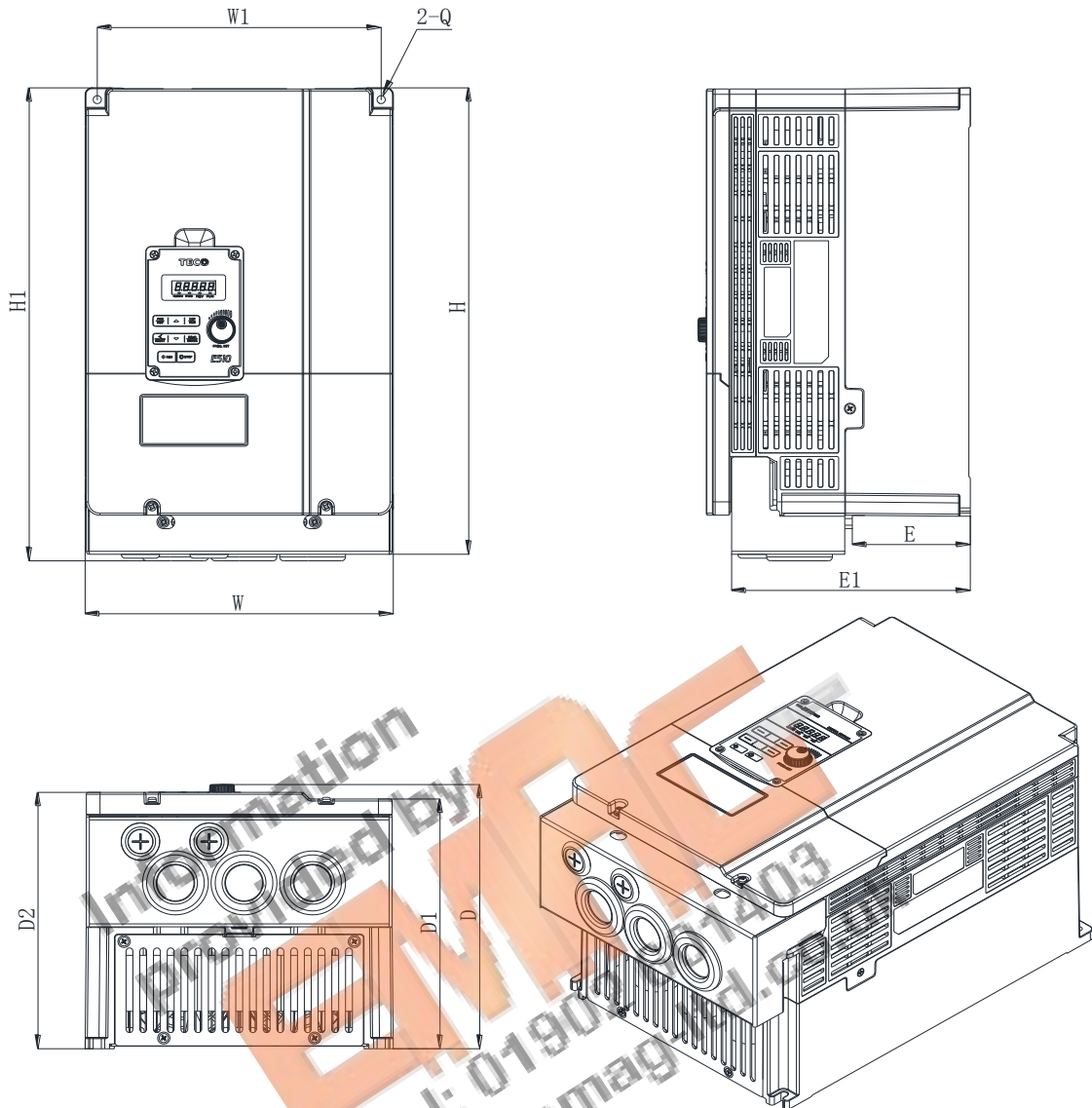

Unit: mm(inch)

Model	Dimensions										N.W (Kg)	
	W	W1	H	H1	D	D1	D2	E	E1	Q		
E510-215-H3												10.5
E510-220-H3	224.6 (8.84)	207 (8.15)	350.1 (13.78)	355.1 (13.98)	200.5 (7.9)	187.5 (7.38)	192.5 (7.58)	86 (3.89)	174 (6.85)	4.5 (0.18)		10.5
E510-420-H3												10.9
E510-425-H3												11



**Frame 2 (IP66/NEMA 4X)**

**Single/Three phase : 200V 2~3HP; Single phase : 200V 2~3HP; Three phase : 200V5HP; 400V 3~5HP ;**

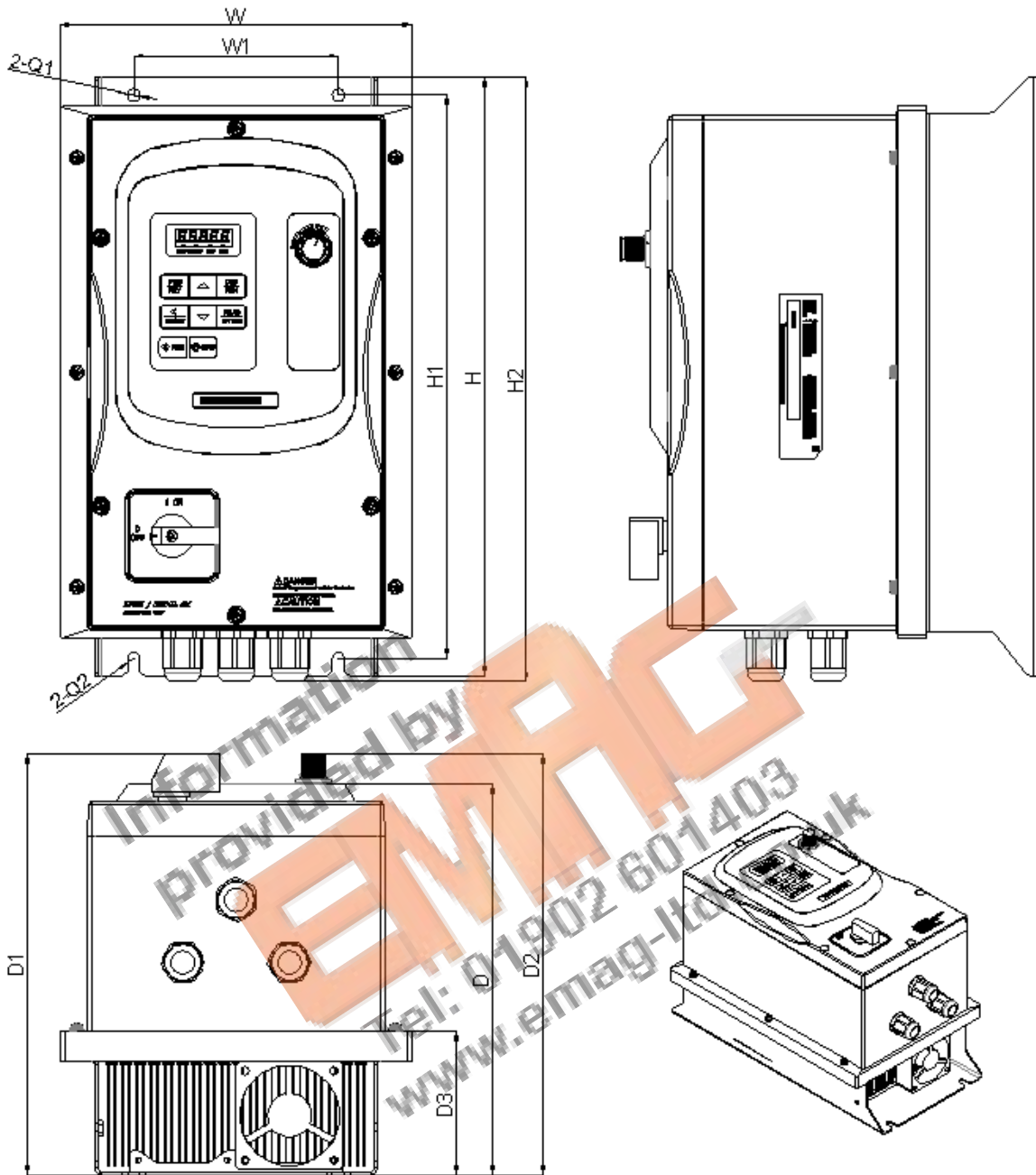

**Unit: mm(inch)**

Model	dimensions											N.W (kg)
	W	W1	H	H1	H2	D	D1	D2	D3	Q1	Q2	
E510-202-HN4R	198	115	335	315	337.9	218.4		235.2	79.8	7	7	5.98
E510-202-H1FN4S							235.2	235.2				
E510-203-HN4R								235.2				
E510-203-H1FN4S							235.2	235.2				
E510-205-H3N4												
E510-403-H3N4												
E510-403-H3FN4S							235.2	235.2				
E510-405-H3N4												
E510-405-H3FN4S							235.2	235.2				



**Frame 3 (IP66/NEMA 4X)**

**Three phase : 200V 7.5~20HP ; 400V 7.5~25HP**

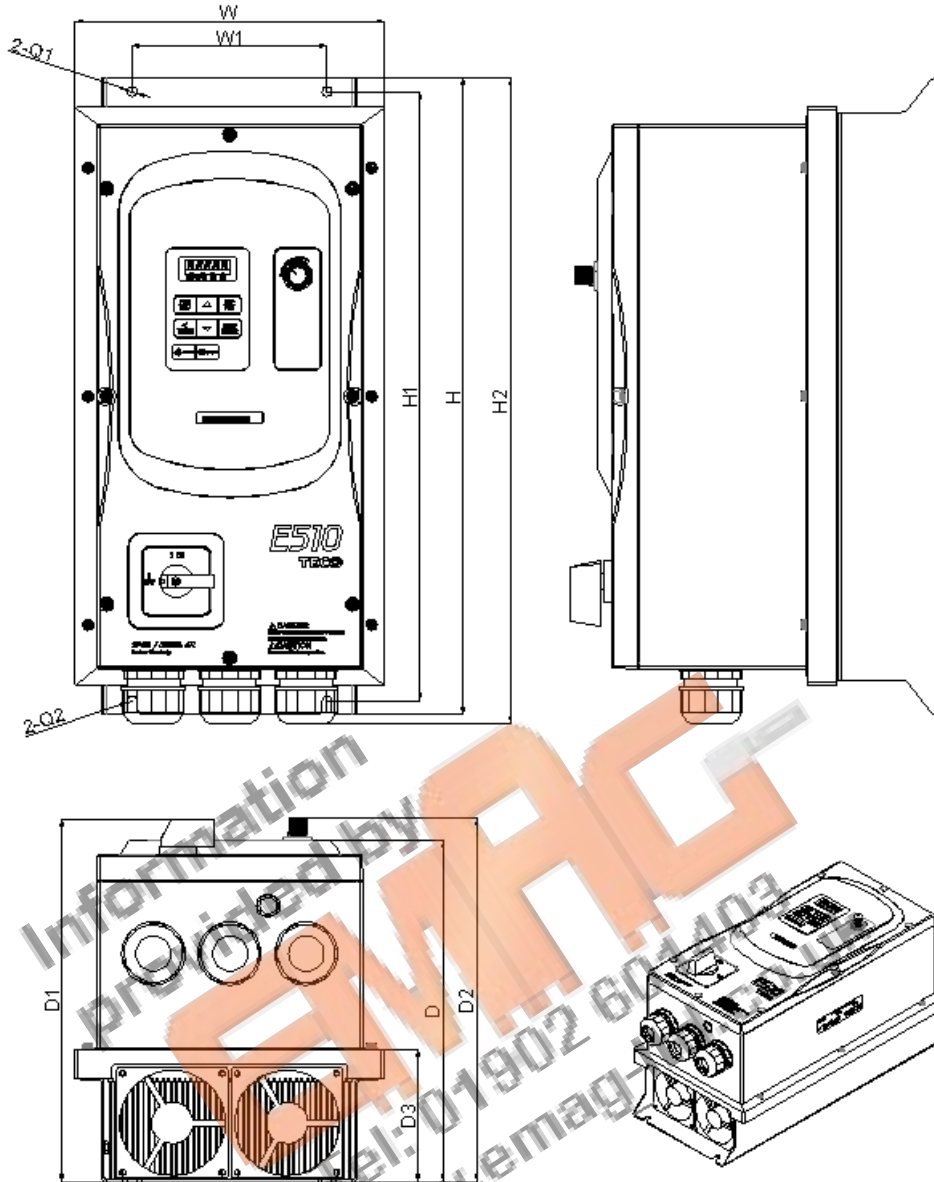

**Unit: mm(inch)**

Model	Dimensions											N.W (kg)
	W	W1	H	H1	H2	D	D1	D2	D3	Q1	Q2	
E510-208-H3N4												
E510-210-H3N4												
E510-215-H3N4												
E510-220-H3N4												
E510-408-H3N4												
E510-408-H3FN4S	222.8	140	460	440	466.3	246.6	266.5	263.5	96	7	7	12.68
E510-410-H3N4												
E510-410-H3FN4S							266.5	263.5				
E510-415-H3N4												
E510-415-H3FN4S							266.5	263.5				
E510-420-H3N4												
E510-425-H3N4												

## 3.8 EMC Filter Disconnection

EMC filter may be disconnected:

Inverter drives with built-in EMC filter are not suitable for connection to certain type of supply systems, such as listed below; in these cases the RFI filter can be disabled.

In all such cases consult your local electrical standards requirements.

IT type supply systems (ungrounded) & certain supply systems for medical equipment.

For ungrounded supply systems If the filter is not disconnected the supply system becomes connected to Earth through the Y capacitors on the filter circuit. This could result in danger and damage to the Drive.

Disconnection steps :

1. Remove the front cover.
2. Loosen the screw.
3. Remove the metal link.
4. Tighten the screw.

Note:- Disconnecting the EMC filter link will disable the filter function, please consult your local EMC standards requirement.

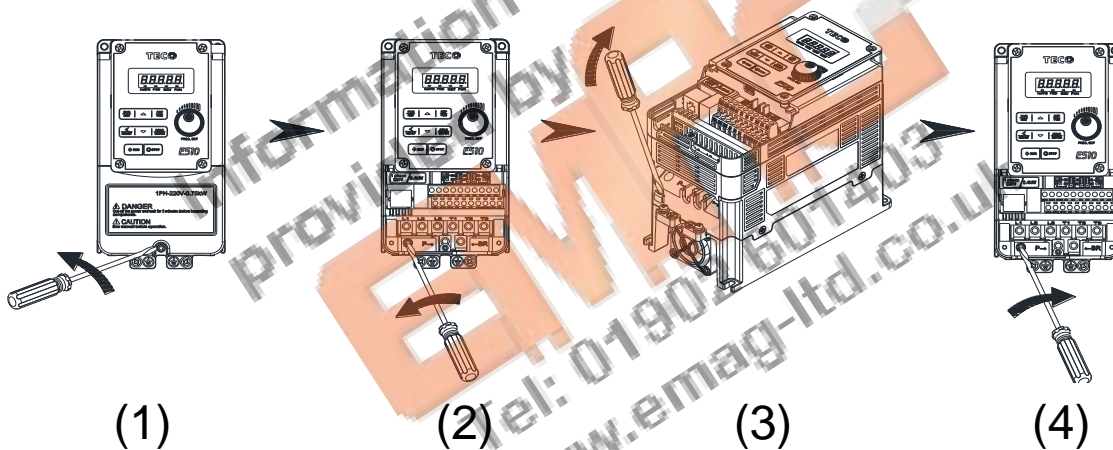

### 3.9 The Dimension and Installation of Operator panel

#### 3.9.1 Description of dimension and installation

(IP20/NEMA1) The operator panel has a LED display and can be removed for remote installation. Installation and dimension information are as follows..

- Dimension

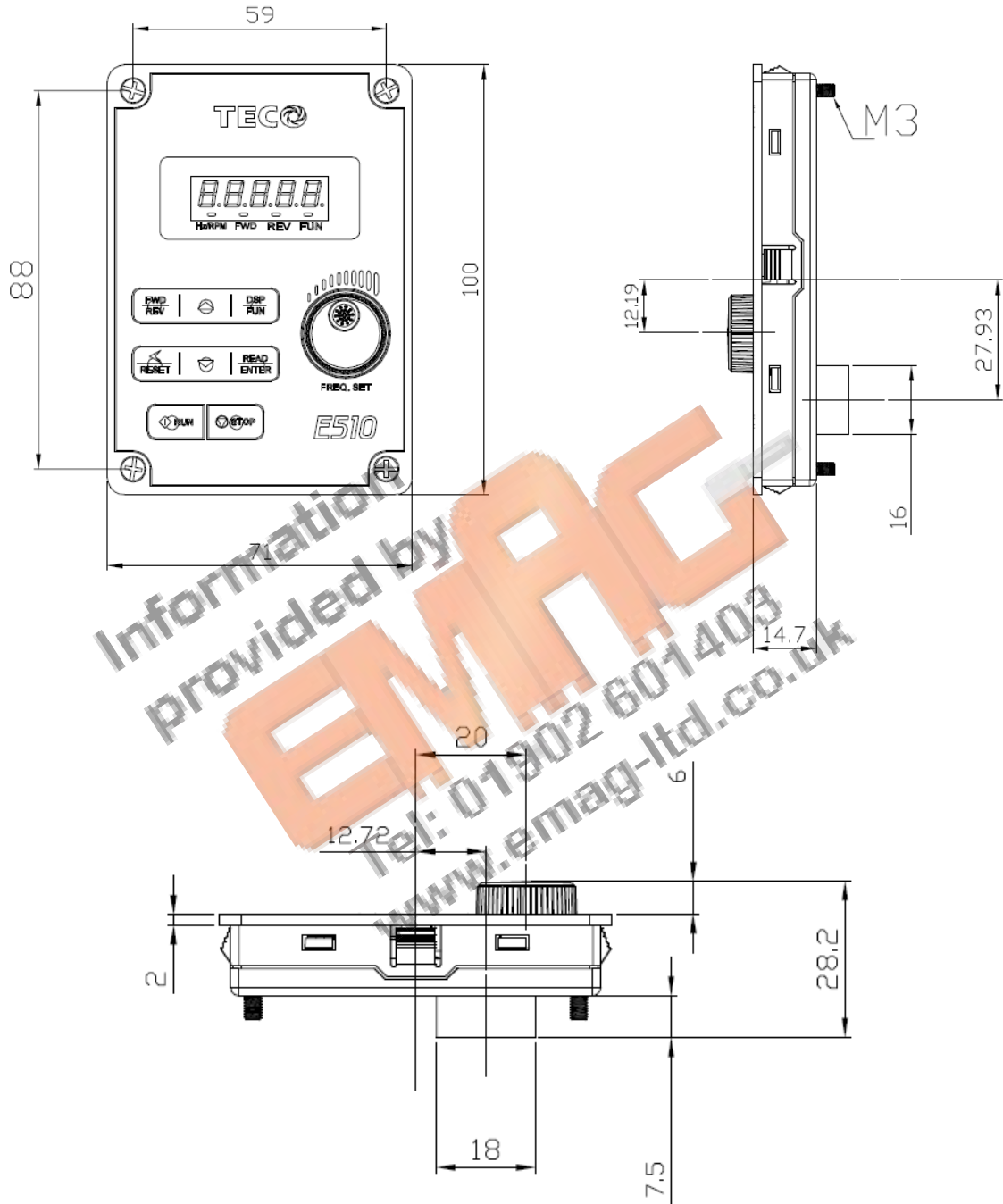

- Surface installation diagram

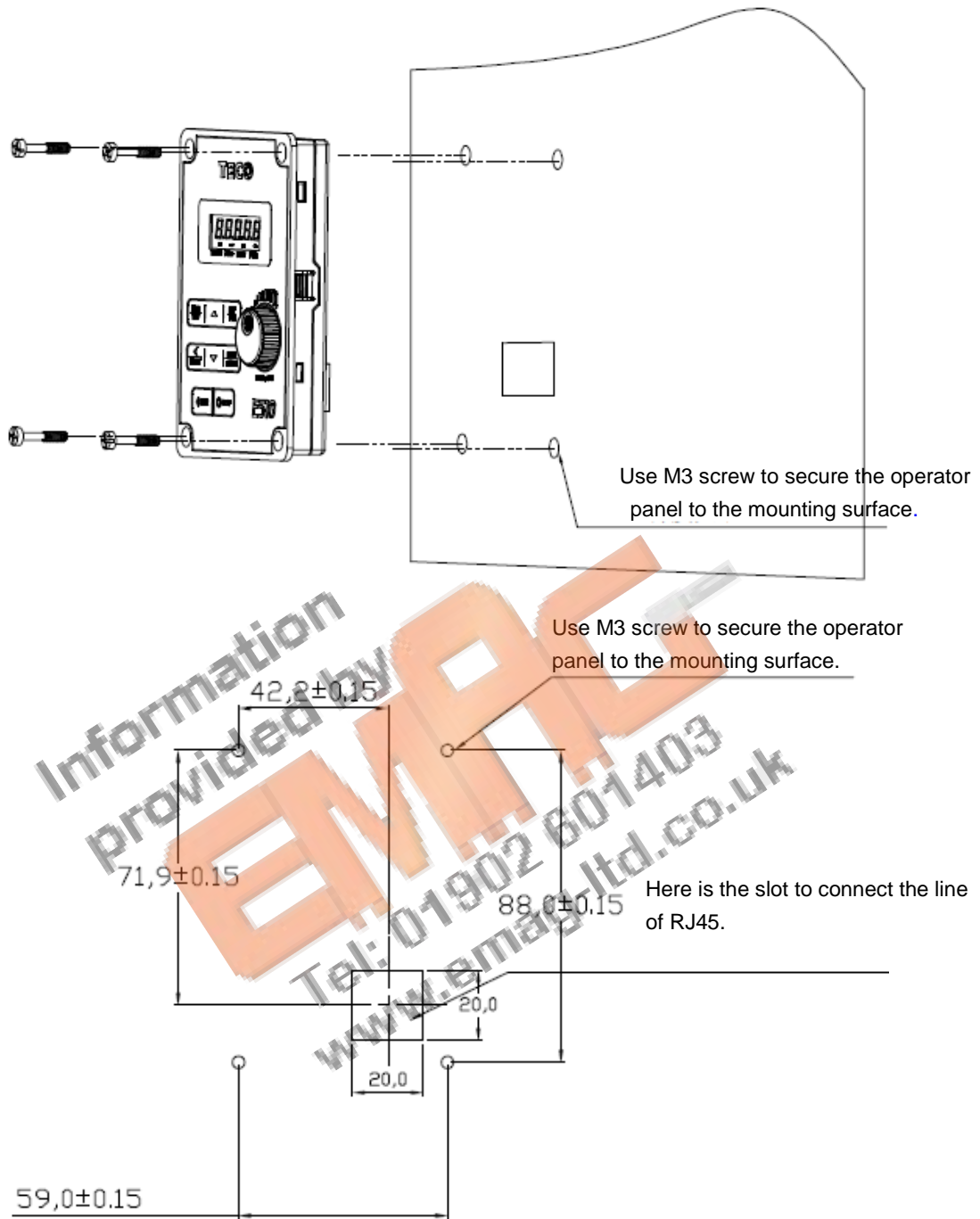

### 3.9.2 Description of Protective Cover

For remote installation of the operator panel, to avoid ingress of dust, use the supplied protective cover.

Step1: Loosen the four screws of the operator panel.

Step 2: Take out the operator panel.

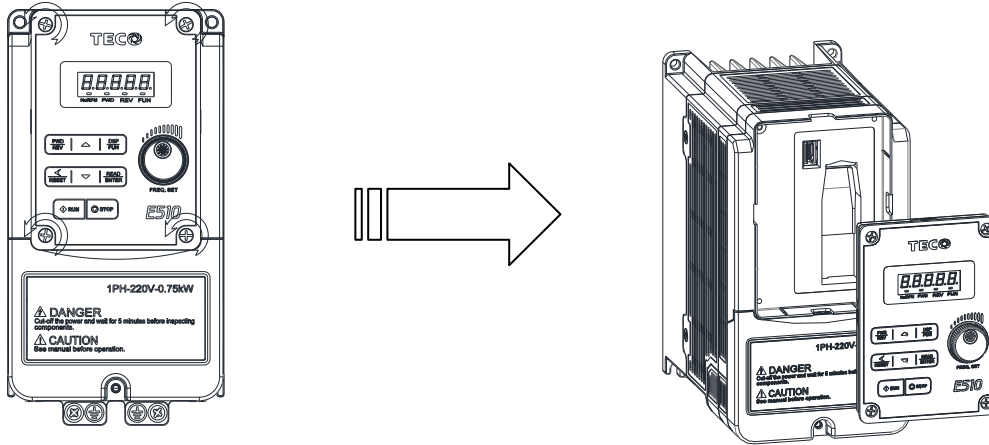

Step 3: Mount the self-adhesive protective cover as per diagram below. Push into position to locate..

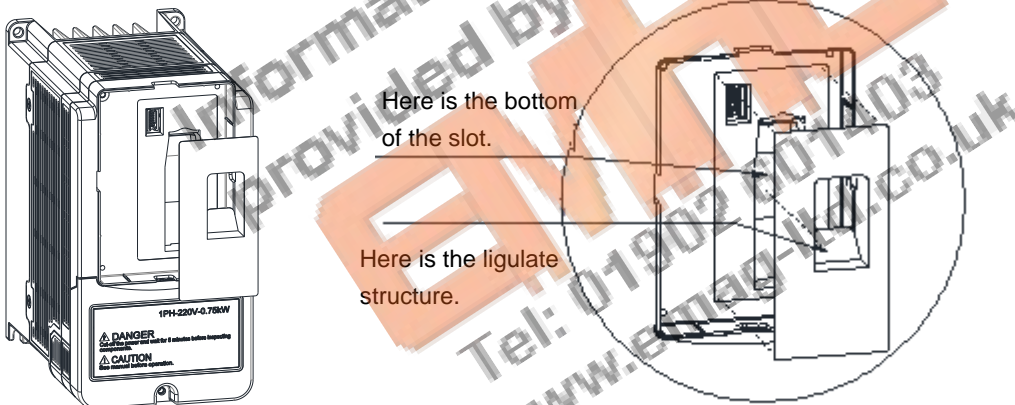

Step 4: Installation is completed.

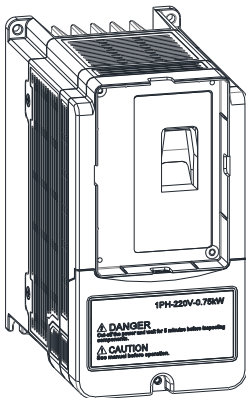



# Chapter 4 Software Index

## 4.1 Keypad Description

### 4.1.1 Operator Panel Functions

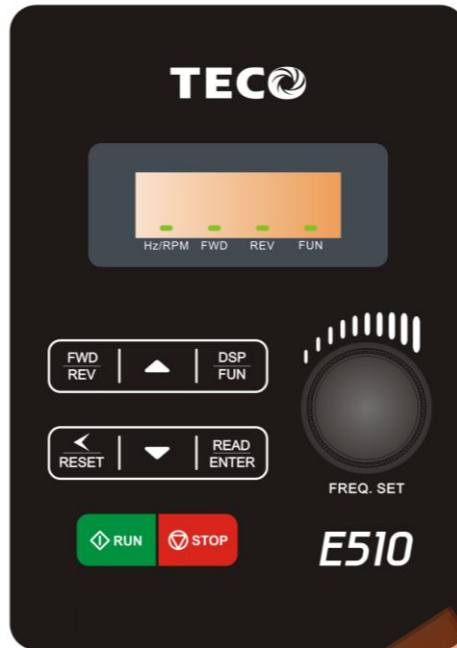

Type	Item	Function
Digital display & LEDs	Main digital displays	Frequency Display, Parameter, voltage, Current, Temperature, Fault messages.
	LED Status	Hz/RPM: ON when the frequency or line speed is displayed. OFF when the parameters are displayed. FWD: ON while the inverter is running forward. Flashes while stopped. REV: ON while the inverter is running reverse. Flashes while stopped. FUN: ON when the parameters are displayed. OFF when the frequency is displayed.
Variable Resistor	FREQ SET	Used to set the frequency
Keys On Keypad (8 buttons)	RUN	RUN: Run at the set frequency.
	STOP	STOP: Decelerate or Coast to Stop.
	▲	Increment parameter number and preset Values.
	▼	Decrement parameter number and preset Values.
	FWD/REV (Dual function keys)	FWD: Forward Run REV: Reverse Run
	DSP/FUN (Dual function keys)	DSP: Switch between available displays FUN: Used to examine the parameter content
	READ/ENTER (Dual function keys)	READ:ENTER: Used to display the preset Value of parameters and for saving the changed parameter Values.
	</ RESET (Dual function keys)	"<"Left Shift: used while changing the parameters or parameter Values RESET: Use to Reset alarms or resettable faults

## 4.1.2 Digital display Description

### Alpha numerical display format

Digit	LED	Letter	LED	Letter	LED	Symbol	LED
0		A		n		-	
1		b		o		°	
2		C		P		_	
3		d		q		.	
4		E		r			
5		F		S			
6		G		t			
7		H		u			
8		J		v			
9		L		Y			

### Digital tube lights flashing instructions

Actual output frequency	Set frequency	
Digits are lit Continually	Preset digits flashing	Selected digit flashing

## LED display examples

Display	Description
	In stop mode shows the set frequency In run mode shows the actual output frequency
	Selected Parameter
	Parameter Value
	Output Voltage
	Output Current in Amps
	DC Bus voltage
	Temperature
	PID feedback Value
	Error display
	Analogue Current / Voltage AI1 / AI2 . Range ( 0~1000)

## LED Status description

	LED Indicator light status			
Frequency / Line speed Indicator	Hz/RPM	ON while displaying frequency or linear speed		
Menu mode indicator	FUN	ON while not displaying frequency or line speed	FUN	Flashing while fire mode enabled
FWD indicator	FWD	ON while running forward	FWD	Flashing while stopped in Forward mode.
REV indicator	REV	ON while running reverse	REV	Flashing while stopped in Reverse mode

### 4.1.3 Digital display set up

On power up digital display screens will be as shown below.

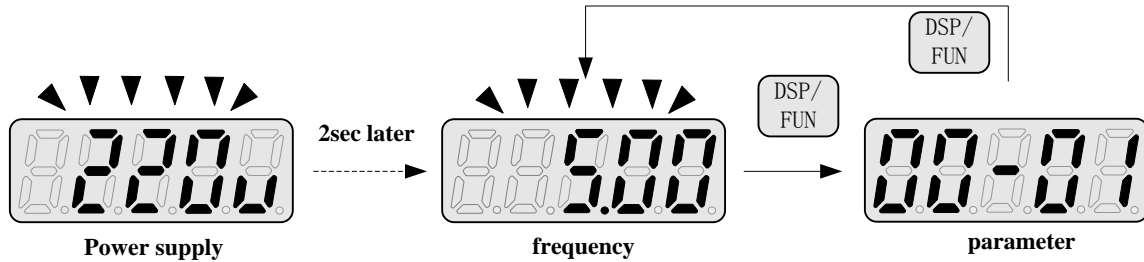

#### User selectable display formats:

12- 00	Display Mode
Range	0 0 0 0 0
	High Low
	Each of the above 5 digits can be set to any of the selections below from 0 to 8
	<b>【0】</b> :Disable display <b>【1】</b> :output Current <b>【2】</b> :output Voltage <b>【3】</b> :DC voltage <b>【4】</b> :Temperature <b>【5】</b> :PID feedback <b>【6】</b> :AI1 <b>【7】</b> :AI2 <b>【8】</b> :count Value

The highest bit of 12-00 sets the power on the display, other bits set the selected display from range 0-7.as listed above.

**Example1: Set parameter 12- 00= 【10000】 to obtain display format shown below.**

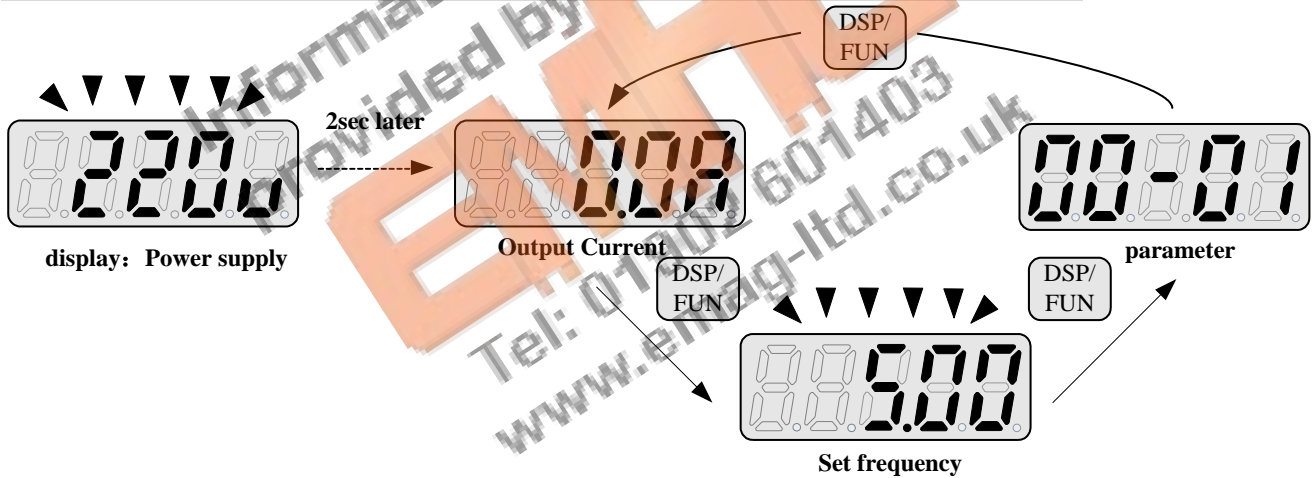

**Example 2. Set parameter 12- 00= [12345] to obtain the display format shown below.**

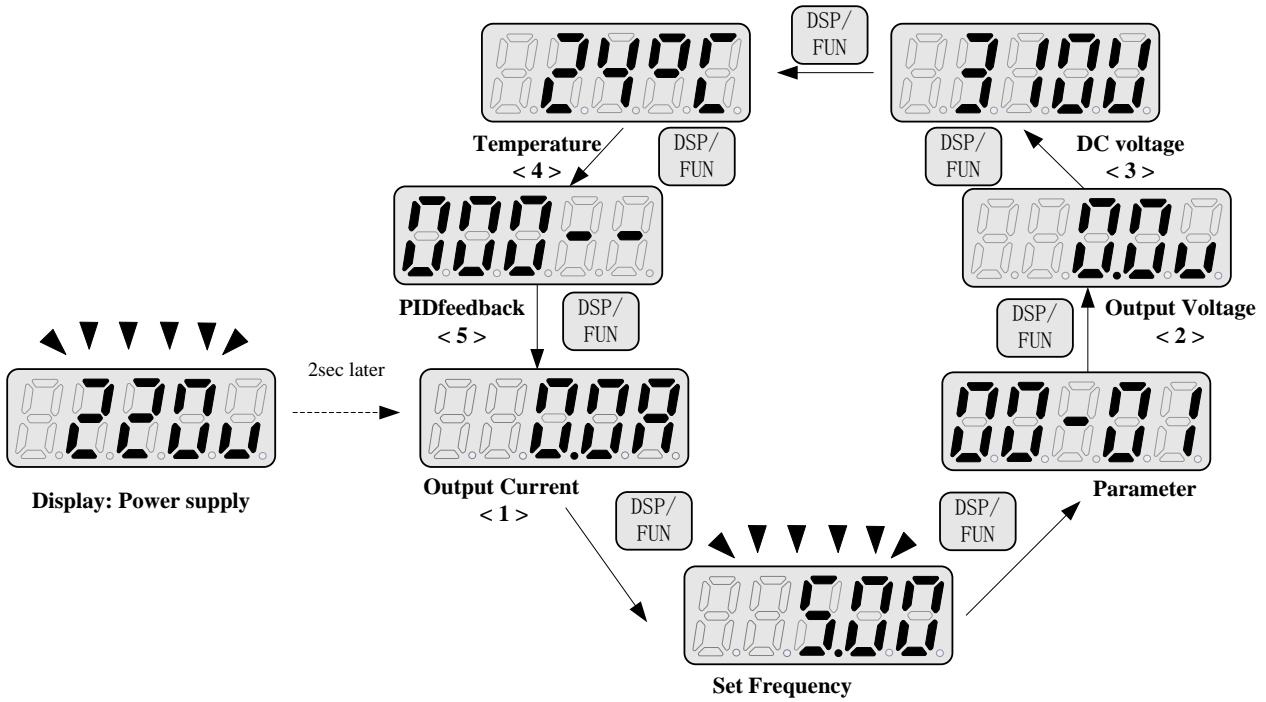

Increment/ Decrement key functions:

1. “▲”/ “▼”:



Quick pressing of these keys will Increment or Decrement the selected digit by one. Extended pressing will Increment or Decrement the selected digit continuously.

#### 4.1.4 Example of keypad operation

**Example1: Modifying Parameters**

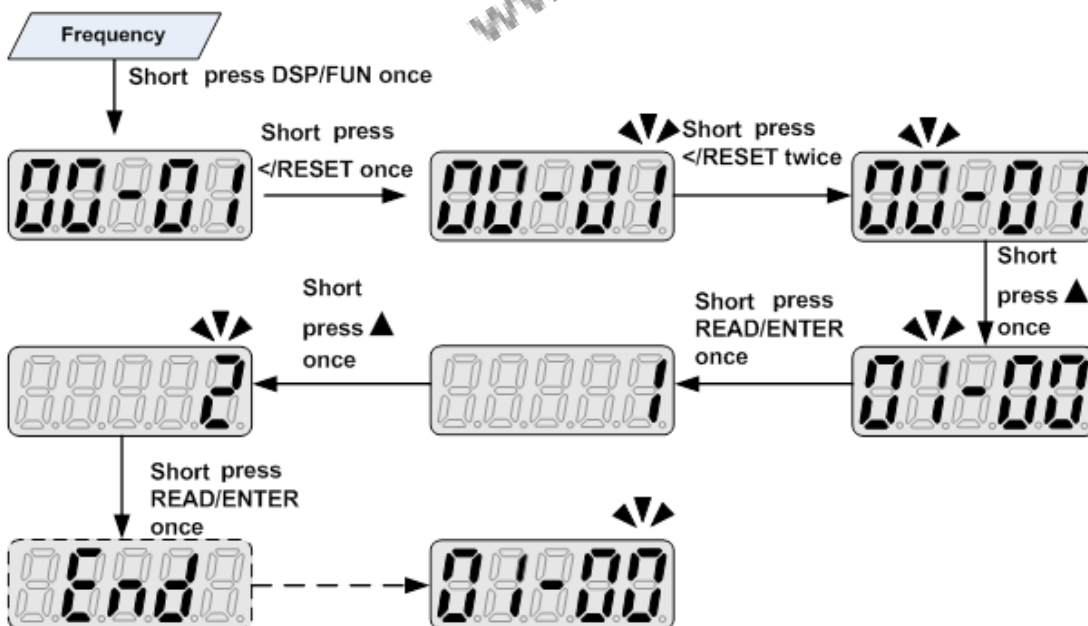



**Example2: Modifying the frequency from keypad in run and stop modes.**

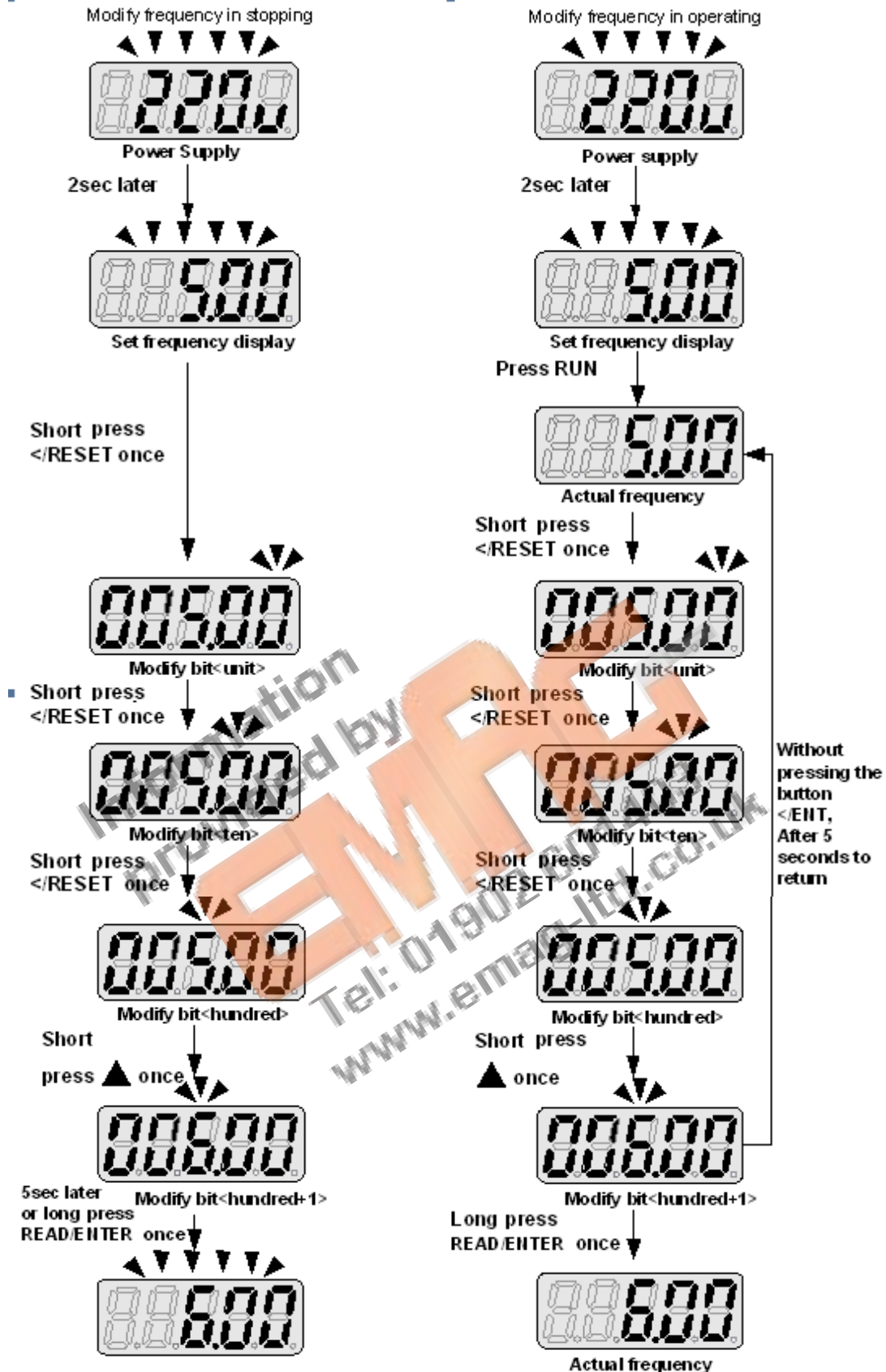

**Note:** Frequency command setting will be limited to the range set by parameters for lower & upper frequency.

### 4.1.5 Operation Control

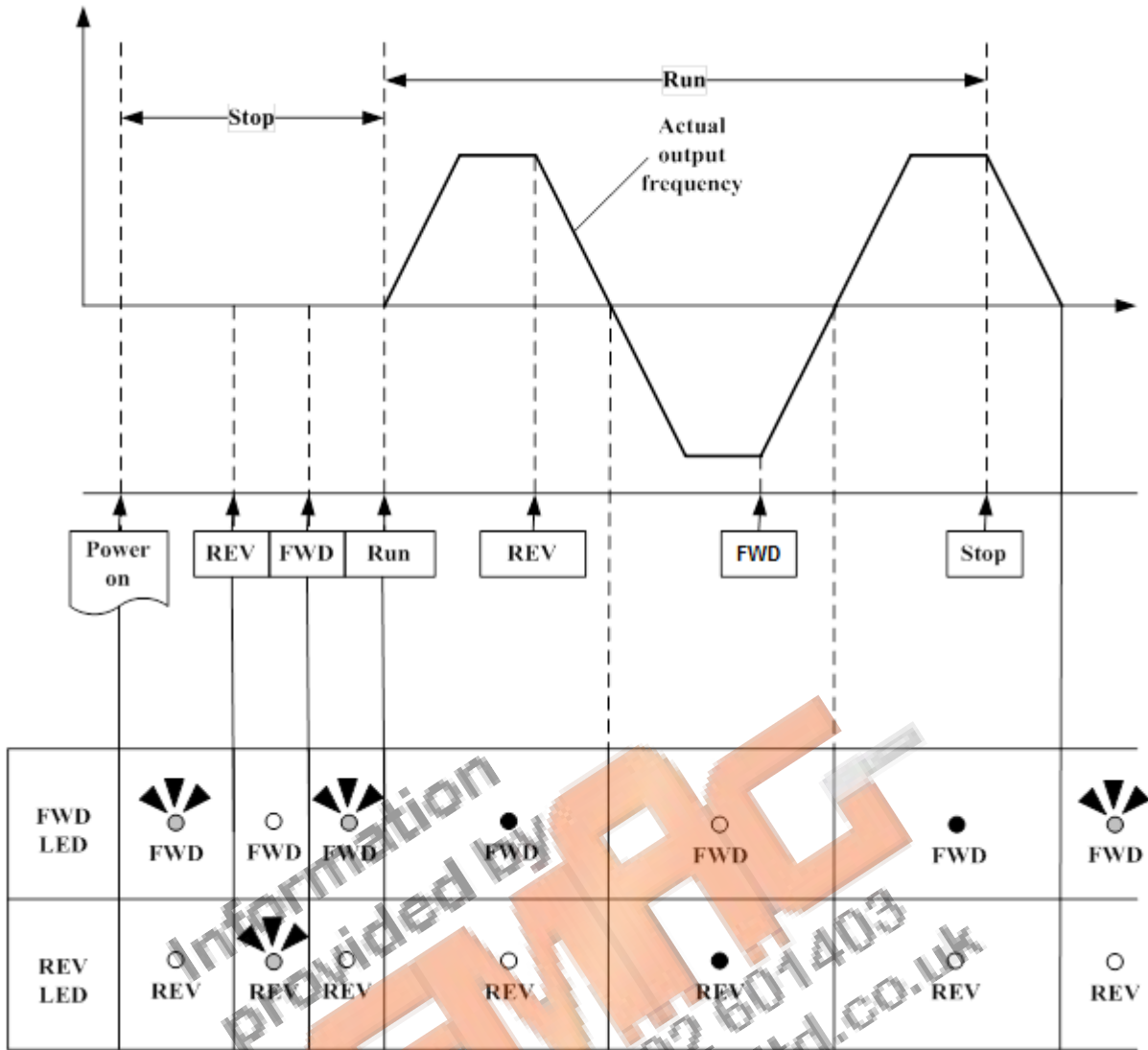

## 4.2 Programmable Parameter Groups

Parameter Group No.	Description
Group 00	Basic Parameters
Group 01	V/F Pattern Selections and Setup
Group 02	Motor Parameters
Group 03	Multi Function Digital Inputs/Outputs
Group 04	Analog Signal Inputs/Output
Group 05	Preset Frequency Selections
Group 06	Auto Run Function(Auto Sequencer)
Group 07	Start/Stop Command Setup
Group 08	Drive and Motor Protection
Group 09	Communication Function Setup
Group 10	PID Function Setup
Group 11	Performance Control Functions
Group 12	Digital Display & Monitor Functions
Group 13	Inspection & Maintenance Functions
Group 14	PLC Setting Function
Group 15	PLC Monitoring Function

Parameter notes for Parameter Groups	
*1	Parameter can be adjusted during running mode
*2	Cannot be modified in communication mode
*3	Does not change with factory reset
*4	Read only
*5	Available for above V1.1
*6	Available for above V1.3
*7	Available for above V1.7

Group 00- Basic parameters					
No.	Description	Range	Factory Setting	Unit	Note
00-00	Control Mode Selection	0:V/F Mode	0	-	
		1:Vector Mode			
00-01	Reserved				
00-02	Main Run Command Source Selection	0:Keypad	0	-	
		1:External Run/Stop Control			
		2:Communication			
		3:PLC			
00-03	Alternative Run Command Source Selection	0:Keypad	0	-	
		1:External Run/Stop Control			
		2:Communication			
00-04	Operation Modes for External Terminals	0:Forward/Stop-Reverse/Stop	0	-	
		1:Run/Stop- Reverse/Forward			
		2: 3 Wire Control Mode-Run/Stop			
00-05	Main Frequency Command Source Selection	0:UP/DOWM of Keypad	0	-	
		1:Potentiometer on Keypad			
		2:External AI1 Analog Signal Input			
		3:External AI2 Analog Signal Input			
		4:External Up/Down Frequency Control			
		5:Communication Setting Frequency			
		6:PID Ouput Frequency			
7:Pulse Input	*6				
00-06	Alternative Frequency Command Source Selection	0:UP/DOWM of Keypad	4	-	
		1:Potentiometer on Keypad			
		2:External AI1 Analog Signal Input			
		3:External AI2 Analog Signal Input			
		4:External Up/Down Frequency Control			
		5:Communication Setting Frequency			
		6:PID Ouput Frequency			
7:Pulse Input	*6				
00-07	Main and Alternative Frequency Command Modes	0:Main or Alternative Frequency 1:Main Frequency+ Alternative Frequency	0	-	
00-08	Communication Frequency Command	0.00~650.00	60.00	Hz	*4
00-09	Frequency Command Save on Power Down	0: Disable	0	-	
		1: Enable			
00-10	Initial Frequency Selection (keypad mode)	0:by Current Frequency Command	0	-	
		1:by 0 Frequency Command			
		2:by 00-11			
00-11	Initial Frequency Setpoint	0.00~650.00	50.00/60.00	Hz	
00-12	Frequency Upper Limit	0.01~650.00	50.00/60.00	Hz	
00-13	Frequency Lower Limit	0.00~649.99	0.00	Hz	
00-14	Acceleration Time 1	0.1~3600.0	10.0	Sec	*1
00-15	Deceleration Time 1	0.1~3600.0	10.0	Sec	*1
00-16	Acceleration Time 2	0.1~3600.0	10.0	Sec	*1
00-17	Deceleration Time 2	0.1~3600.0	10.0	Sec	*1
00-18	Jog Frequency	0.00~650.00	2.00	Hz	*1
00-19	Jog Acceleration Time	0.1~3600.0	0.5	Sec	*1
00-20	Jog Deceleration Time	0.1~3600.0	0.5	Sec	*1

Group 01- V/F Pattern selection & Setup					
No.	Description	Range	Factory Setting	Unit	Note
01-00	Volts/Hz Patterns	0~18	0/9	-	
01-01	V/F Max voltage	200V:170.0~264.0 400V:323.0~528.0	220.0/440.0	Vac	
01-02	Max Frequency	0.20 ~ 650.00	50.00/60.00	Hz	
01-03	Max Frequency Voltage Ratio	0.0 ~ 100.0	100.0	%	
01-04	Mid Frequency 2	0.10 ~ 650.00	25.00/30.00	Hz	
01-05	Mid Frequency Voltage Ratio 2	0.0 ~ 100.0	50.0	%	
01-06	Mid Frequency 1	0.10 ~ 650.00	10.00/12.00	Hz	
01-07	Mid Frequency Voltage Ratio 1	0.0 ~ 100.0	20.0	%	
01-08	Min Frequency	0.10 ~ 650.00	0.50/0.60	Hz	
01-09	Min Frequency Voltage Ratio	0.0 ~ 100.0	1.0	%	
01-10	Volts/Hz Curve Modification (Torque Boost)	0 ~ 10.0	0.0	%	*1
01-11	V/F start Frequency	0.00~10.00	0.00	Hz	
01-12	Slip compensation gain	0.05~10.00	0.10	S	
01-13	V/F Mode Select	0 : Mode 0 1 : Mode 1	0	-	

Group 02- Motor parameters					
No.	Description	Range	Factory Setting	Unit	Note
02-00	Motor No Load Current	0~[(Parameter 02-01)-0.1]	-	Amps(AC)	*4
02-01	Motor Rated Current (OL1)	0.2~100	-	A	*4
02-02	Motor rated Slip Compensation	0.0 ~ 200.0	0.0	%	*1
02-03	Motor rated speed	0~39000	-	Rpm	*4
02-04	Motor rated voltage	200V: 170.0~264.0 400V: 323.0~528.0	220.0/440.0	V	
02-05	Motor rated power	0.1~37.0	-	KW	
02-06	Motor rated frequency	0~650.0	50.0/60.0	Hz	
02-07	Motor pole number	2~16	4	-	
02-08 ~ 02-13	Reserved				
02-14	Auto Tune	0: Disable 1: Start Auto tune function.	0		
02-15	Stator resistance gain	----			*3*4
02-16	Rotor resistance gain	----			*3*4



Group 03- External Digital Inputs and Relay Output Functions					
No.	Description	Range	Factory Setting	Unit	Note
03-00	Multifunction Input Term. S1	0:Forward/Stop Command	0	-	
03-01	Multifunction Input Term. S2	1:Reverse/Stop Command	1	-	
03-02	Multifunction Input Term. S3	2:Preset Speed 0(5-02)	2	-	
03-03	Multifunction Input Term. S4	3:Preset Speed 1(5-03)	3	-	
03-04	Multifunction Input Term. S5	4:Preset Speed 2(5-05)	4	-	
03-05	Multifunction Input Term. S6	5:Preset Speed 3(5-09)	17		
		6:Jog Forward Command			
		7:Jog Reverse Command			
		8:Up Command			
		9:Down Command			
		10:Acc/Dec 2			
		11:Acc/Dec Disabled			
		12:Main/Alternative run source select			
		13:Main/ Alternative Frequency Command select			
		14:Rapid Stop ( Decel to stop )			
		15:Base Block			
		16:Disabl PID Function			
		17: Fault Reset			
		18:Auto Run Mode Enable			
		19:Speed Search			
		20:Energy Saving (only V/F)			
		21:Reset PID integral value to Zero			
22:Counter Input					
23:Counter reset					
24:PLC Input					
25:Pulse Input-Width Measure (S3)	*6				
26:Pulse Input-Frequenct Measure (S3)	*6				
27:Enable KEB Function					
28:Fire mode function (Valid for software issued after rev. 1.1)					
03-06	Up/Down frequency step	0.00~5.00	0.00	Hz	
03-07	Up/Down Keep Frequency Status after Stop Command	0:When Up/Down is used, the preset frequency is held as the inverter stops, and the UP/Down function is disabled	0	-	
		1:When Up/Down is used, the preset frequency is reset to 0 Hz as the inverter stops.			
		2:When Up/Down is used, the preset frequency is held as the inverter stops, and the UP/Down is available.			
03-08	S1 ~ S6 scan confirmation	1~200 Number of Scan cycles	10	2ms	
03-09	S1~ S5 switch type select	xxxx0:S1 NO xxx1:S1 NC	00000	-	
		xxx0x:S2 NO xxx1x:S2 NC			
		xx0xx:S3 NO xx1xx:S3 NC			
		x0xxx:S4 NO x1xxx:S4 NC			
		0xxxx:S5 NO 1xxxx:S5 NC			

Group 03- External Digital Inputs and Relay Output Functions					
No.	Description	Range	Factory Setting	Unit	Note
03-10	S6 switch type select	xxxx0:S6 NO xxx1:S6 NC	00000	-	
03-11	Output Relay RY1 ( Terminals R1A,R1B, R1C )	0:Run	0	-	
03-12	Output Relay RY2. ( Terminals R2A, R2B )	1:Fault	1		
		2:Setting Frequency Reached			
		3:Frequency Reached. Set by (3-13±3-14)			
		4:Output Frequency Detection1(> 3-13)			
		5:Output Frequency Detection2(< 3-13)			
		6:Auto Restart			
		7:Momentary AC Power Loss			
		8:Rapid Stop			
		9:Base Block			
		10:Motor Overload Protection(OL1)			
		11:Drive Overload Protection(OL2)			
		12:Over-torque Threshold Level (OL3)			
		13:Preset Output Current Reached (03-15~16)			
		14:Brake Control (03-17~18)			
		15:PID Feedback Signal Loss			
		16: Single pre-set count (3-22)			
		17: Dual pre-set count (3-22~23)			
		18:PLC Status Indicator (00-02)			
		19:PLC control			
		20:Zero Speed			
03-13	Frequency Reached Level	0.00~650.00	0.00	Hz	*1
03-14	Frequency Reached Detection Range (±)	0.00~30.00	2.00	Hz	*1
03-15	Preset output current reached	0.1~15.0	0.1	A	
03-16	Preset output Current detection delay Time	0.1~10.0	0.1	Sec	
03-17	Brake Release level	0.00~20.00	0.00	Hz	
03-18	Brake Engage Level	0.00~20.00	0.00	Hz	
03-19	Relay Output function type	0:A (Normally open) 1:B (Normally close)	0	-	
03-20	Internal / external multi-function input terminal selection	0~63	0	-	
03-21	Action to set the internal multi-function input terminals	0~63	0	-	
03-22	Pre-set count 1	0~9999	0	-	
03-23	Pre-set count 2	0~9999	0	-	
03-24	Output under current detection	0:Disable	0	-	
		1:Enable			
03-25	Output under current detection level	5%~100%	20%	%	
03-26	Output under current detection delay time	0.0~50.0s	20.0	Sec	

Group 03- External Digital Inputs and Relay Output Functions					
No.	Description	Range	Factory Setting	Unit	Note
03-27	Pulse Frequency	0.01~0.20	0.1	kHz	*6
03-28	Pulse Frequency Gain	0.01~9.99	1.00		*6

※ "NO" indicates normally open, "NC" indicates normally closed.

Information  
provided by  
**EMAG**  
Tel: 01902 601403  
www.emag-ltd.co.uk

Group 04- Analog signal inputs / Analog output					
No.	Description	Range	Factory Setting	Unit	Note
04-00	Analog Input Signal Type Select (AI1/AI2)	AI1 AI2	1	-	
		(0): 0~10V (0~20mA) 0~10V (0~20mA)			
		(1): 0~10V (0~20mA) 2~10V (4~20mA)			
		(2): 2~10V (4~20mA) 0~10V (0~20mA)			
04-01	AI1 Signal Verification Scan Rate	1~200	50	2ms	
04-02	AI1 Gain	0 ~ 1000	100	%	*1
04-03	AI1 Bias	0 ~ 100	0	%	*1
04-04	AI1 Bias Selection	0: Positive 1: Negative	0	-	*1
04-05	AI1 Slope	0: Positive 1: Negative	0	-	*1
04-06	AI2 Signal Verification Scan Rate	1~200	50	2ms	
04-07	AI2 Gain	0 ~ 1000	100	%	*1
04-08	AI2 Bias	0 ~ 100	0	%	*1
04-09	AI2 Bias Selection	0: Positive 1: Negative	0	-	*1
04-10	AI2 Slope	0: Positive 1: Negative	0	-	*1
04-11	Analog Output (AO) Mode	0: Output Frequency 1: Frequency Command 2: Output Voltage 3: DC Bus Voltage 4: Motor Current (100% rated current)	0	-	*1
04-12	Analog Output (AO) Gain	0 ~ 1000	100	%	*1
04-13	Analog Output (AO) Bias	0 ~ 100	0	%	*1
04-14	AO Bias Selection	0: Positive 1: Negative	0	-	*1
04-15	AO Slope	0: Positive 1: Negative	0	-	*1
04-16	F-Gain Function	0: Invalid 1: Effective	0	-	*1

Group 05- Preset Frequency Selections					
No.	Description	Range	Factory Setting	Unit	Note
05-00	Preset Speed Control Mode Selection	0: Common Accel/Decel Accel/Decel 1 or 2 apply to all speeds	0	-	
		1: Individual Accel/Decel for each preset speed 0-15 apply to the selected preset speeds (Acc0/Dec0~Acc15/Dec15)			
05-01	Preset Speed 0 (Keypad Freq)	0.00 ~ 650.00	5.00	Hz	
05-02	Preset Speed1 (Hz)		5.00	Hz	*1
05-03	Preset Speed2 (Hz)		10.00	Hz	*1
05-04	Preset Speed3 (Hz)		20.00	Hz	*1
05-05	Preset Speed4 (Hz)		30.00	Hz	*1
05-06	Preset Speed5 (Hz)		40.00	Hz	*1
05-07	Preset Speed6 (Hz)		50.00	Hz	*1
05-08	Preset Speed7 (Hz)		50.00	Hz	*1
05-09	Preset Speed8 (Hz)		0.00	Hz	*1
05-10	Preset Speed9 (Hz)		0.00	Hz	*1
05-11	Preset Speed10 (Hz)		0.00	Hz	*1
05-12	Preset Speed11 (Hz)		0.00	Hz	*1
05-13	Preset Speed12 (Hz)		0.00	Hz	*1
05-14	Preset Speed13 (Hz)		0.00	Hz	*1
05-15	Preset Speed14 (Hz)		0.00	Hz	*1
05-16	Preset Speed15 (Hz)		0.00	Hz	*1
05-17	Preset Speed0-Acctime		0.1 ~ 3600.0	10.0	Sec
05-18	Preset Speed0-Dectime	10.0		Sec	*1
05-19	Preset Speed1-Acctime	10.0		Sec	*1
05-20	Preset Speed1-Dectime	10.0		Sec	*1
05-21	Preset Speed2-Acctime	10.0		Sec	*1
05-22	Preset Speed2-Dectime	10.0		Sec	*1
05-23	Preset Speed3-Acctime	10.0		Sec	*1
05-24	Preset Speed3-Dectime	10.0		Sec	*1
05-25	Preset Speed4-Acctime	10.0		Sec	*1
05-26	Preset Speed4-Dectime	10.0		Sec	*1
05-27	Preset Speed5-Acctime	10.0		Sec	*1
05-28	Preset Speed5-Dectime	10.0		Sec	*1
05-29	Preset Speed6-Acctime	10.0		Sec	*1
05-30	Preset Speed6-Dectime	10.0		Sec	*1
05-31	Preset Speed7-Acctime	10.0		Sec	*1
05-32	Preset Speed7-Dectime	10.0		Sec	*1
05-33	Preset Speed8-Acctime	10.0		Sec	*1
05-34	Preset Speed8-Dectime	10.0		Sec	*1
05-35	Preset Speed9-Acctime	10.0		Sec	*1
05-36	Preset Speed9-Dectime	10.0		Sec	*1
05-37	Preset Speed10-Acctime	10.0		Sec	*1
05-38	Preset Speed10-Dectime	10.0	Sec	*1	
05-39	Preset Speed11-Acctime	10.0	Sec	*1	



Group 05- Preset Frequency Selections					
No.	Description	Range	Factory Setting	Unit	Note
05-40	Preset Speed11-Dectime		10.0	Sec	*1
05-41	Preset Speed12-Acctime		10.0	Sec	*1
05-42	Preset Speed12-Dectime		10.0	Sec	*1
05-43	Preset Speed13-Acctime		10.0	Sec	*1
05-44	Preset Speed13-Dectime		10.0	Sec	*1
05-45	Preset Speed14-Acctime		10.0	Sec	*1
05-46	Preset Speed14-Dectime		10.0	Sec	*1
05-47	Preset Speed15-Acctime		10.0	Sec	*1
05-48	Preset Speed15-Dectime		10.0	Sec	*1

Group 06- Auto Run Function (Auto Sequencer)					
No.	Description	Range	Factory Setting	Unit	Note
06-00	Auto Run Mode Selection (Sequencer)	0: Disabled. 1: Single cycle. (Continues to run from the Unfinished step if restarted). 2: Periodic cycle. (Continues to run from the unfinished step if restarted). 3: Single cycle, then holds the speed Of final step to run. (Continues to run from the unfinished step if restarted). 4: Single cycle. (Starts a new cycle if restarted). 5: Periodic cycle. (Starts a new cycle if restarted). 6: Single cycle, then hold the speed of final step to run. (Starts a new cycle if restarted).	0	-	
06-01	Auto _ Run Mode Frequency Command 1	0.00~650.00	0.00	Hz	*1
06-02	Auto _ Run Mode Frequency Command 2		0.00	Hz	*1
06-03	Auto _ Run Mode Frequency Command 3		0.00	Hz	*1
06-04	Auto _ Run Mode Frequency Command 4		0.00	Hz	*1
06-05	Auto _ Run Mode Frequency Command 5		0.00	Hz	*1

Group 06- Auto Run Function (Auto Sequencer)					
No.	Description	Range	Factory Setting	Unit	Note
06-06	Auto _ Run Mode Frequency Command 6		0.00	Hz	*1
06-07	Auto _ Run Mode Frequency Command 7		0.00	Hz	*1
06-08	Auto _ Run Mode Frequency Command 8		0.00	Hz	*1
06-09	Auto _ Run Mode Frequency Command 9		0.00	Hz	*1
06-10	Auto _ Run Mode Frequency Command10		0.00	Hz	*1
06-11	Auto _ Run Mode Frequency Command 11		0.00	Hz	*1
06-12	Auto _ Run Mode Frequency Command 12		0.00	Hz	*1
06-13	Auto _ Run Mode Frequency Command 13		0.00	Hz	*1
06-14	Auto _ Run Mode Frequency Command 14		0.00	Hz	*1
06-15	Auto _ Run Mode Frequency Command 15		0.00	Hz	*1
06-16	Auto_ Run Mode Running Time Setting 0		0.0	Sec	
06-17	Auto_ Run Mode Running Time Setting 1	0.0 ~ 3600.0	0.0	Sec	
06-18	Auto_ Run Mode Running Time Setting 2		0.0	Sec	
06-19	Auto_ Run Mode Running Time Setting 3		0.0	Sec	
06-20	Auto_ Run Mode Running Time Setting 4		0.0	Sec	
06-21	Auto_ Run Mode Running Time Setting 5		0.0	Sec	
06-22	Auto_ Run Mode Running Time Setting 6		0.0	Sec	
06-23	Auto_ Run Mode Running Time Setting 7		0.0	Sec	
06-24	Auto_ Run Mode Running Time Setting 8		0.0	Sec	
06-25	Auto_ Run Mode Running Time Setting 9		0.0	Sec	
06-26	Auto_ Run Mode Running Time Setting 10		0.0	Sec	

Group 06- Auto Run Function (Auto Sequencer)					
No.	Description	Range	Factory Setting	Unit	Note
06-27	Auto_ Run Mode Running Time Setting 11		0.0	Sec	
06-28	Auto_ Run Mode Running Time Setting 12		0.0	Sec	
06-29	Auto_ Run Mode Running Time Setting 13		0.0	Sec	
06-30	Auto_ Run Mode Running Time Setting 14		0.0	Sec	
06-31	Auto_ Run Mode Running Time Setting 15		0.0	Sec	
06-32	Auto_ Run Mode Running Direction 0	0: Stop 1: Forward 2: Reverse	0	-	
06-33	Auto_ Run Mode Running Direction 1		0	-	
06-34	Auto_ Run Mode Running Direction 2		0	-	
06-35	Auto_ Run Mode Running Direction 3		0	-	
06-36	Auto_ Run Mode Running Direction 4		0	-	
06-37	Auto_ Run Mode Running Direction 5		0	-	
06-38	Auto_ Run Mode Running Direction 6		0	-	
06-39	Auto_ Run Mode Running Direction 7		0	-	
06-40	Auto_ Run Mode Running Direction 8		0	-	
06-41	Auto_ Run Mode Running Direction 9		0	-	
06-42	Auto_ Run Mode Running Direction10		0	-	
06-43	Auto_ Run Mode Running Direction 11		0	-	
06-44	Auto_ Run Mode Running Direction12		0	-	
06-45	Auto_ Run Mode Running Direction13		0	-	
06-46	Auto_ Run Mode Running Direction 14		0	-	
06-47	Auto_ Run Mode Running Direction 15	0	-		

※Frequency of the step 0 is set by parameter 05-01, keypad frequency.

Group 07- Start/Stop Command Setup					
No.	Description	Range	Factory Setting	Unit	Note
07-00	Momentary Power Loss and Restart	0: Momentary Power Loss and Restart Disable 1: Momentary Power Loss and Restart Enable	0	-	
07-01	Auto Restart Delay Time	0.0~800.0	0.0	Sec	
07-02	Number of Auto Restart Attempts	0~10	0	-	
07-03	Reset Mode Setting	0: Enable Reset Only when Run Command is Off 1: Enable Reset when Run Command is On or Off	0	-	
07-04	Direct Running on Power Up	0: Enable Direct run on power up 1: Disable Direct run on power up	1	-	
07-05	Delay-ON Timer	1.0~300.0	1.0	Sec	
07-06	DC Injection Brake Start Frequency	0.10 ~ 10.00	1.5	Hz	
07-07	DC Injection Brake Level (Current Mode)	0.0 ~ 150.0	50.0	%	
07-08	DC Injection Brake Time	0.0 ~ 25.5	0.5	Sec	
07-09	Stopping Method	0: Deceleration to stop 1: Coast to stop	0	-	
07-10	Starting Methods	0: Normal Start 1: Speed Search	0	-	
07-11	Starting method for auto restart after fault	0: Speed Search 1: Normal start	0	-	
07-12	Power Loss Ride Through Time	0.0 ~ 2.0	0.5	Sec	
07-13	Main Circuit Low Voltage Detection Level	150.0~210.0 300.0~420.0	190.0/380.0	Vac	
07-14	Kinetic Energy Back-up Deceleration Time	0.0~25.0: KEB Deceleration Time	0.0	Sec	
07-15	DC Injection Brake Mode	0 : Current Mode 1 : Voltage Mode	1	-	*6
07-16	DC Injection Brake Level (Voltage Mode)	0.0~10.0	4.0	%	*6

**Group 08- Drive & Motor Protection Functions**

No.	Description	Range	Factory Setting	Unit	Note
08-00	Trip Prevention Selection	xxxx0: Enable Trip Prevention During Acceleration xxxx1: Disable Trip Prevention During Acceleration xxx0x: Enable Trip Prevention During Deceleration xxx1x: Disable Trip Prevention During Deceleration xx0xx: Enable Trip Prevention in Run Mode xx1xx: Disable Trip Prevention in Run Mode x0xxx: Enable Over Voltage Prevention in Run Mode x1xxx: Disable Over Voltage Prevention in Run Mode	01000	-	*5
08-01	Trip Prevention Level During Acceleration (%)	50 ~ 200	200	% <sup>1</sup>	
08-02	Trip Prevention Level During Deceleration (%)	50 ~ 200	200		
08-03	Trip Prevention Level in Run Mode (%)	50 ~ 200	200		
08-04	Over Voltage Prevention Level in Run Mode	350.0~390.0/700.0~780.0	380.0/760.0	VD C	
08-05	Electronic Motor Overload Protection Operation Mode	0: Disable 1: Enable	1	-	*7
08-06	Operation After Overload Protection is Activated	0: Coast-to-Stop After Overload Protection is Activated 1: Drive Will Not Trip when Overload Protection is Activated (OL1)	0	-	
08-07	Over Heat Protection (cooling fan control)	0: Auto (Depends on temp.) 1: Operate while in RUN Mode 2: Always Run 3: Disabled	1	-	
08-08	AVR Function (Auto Voltage Regulation)	0: AVR Function is enabled 1: AVR Function is disabled 2: AVR Function is disabled for Stop 3: AVR Function is disabled for Deceleration. 4: AVR Function is disabled for Stop and Deceleration. 5: When VDC>360V, AVR Function is disabled for Stop and Deceleration.	4	-	*5
08-09	Input Phase Loss Protection	0: Disable 1: Enable	0	-	
08-10	Output Phase Loss Protection	0: Disable 1: Enable	0	-	
08-11	Motor Type Selection	0: Overload protection (Standard Motor) 1: Overload protection (Inverter Duty Motor)	0	-	
08-12	Motor Overload Protection Curve	0: Motor Overload Protection for General loads (OL=103 %) (150% for 1 Minutes) 1: Motor Over load Protection for HVAC (Fan & Pump) (OL=113%) (123% for 1 Minutes).	0	-	

<sup>1</sup> Base on the percentage of inverter rated current.

Group 08- Drive & Motor Protection Functions					
No.	Description	Range	Factory Setting	Unit	Note
08-13	Over Torque Detection Control	0: Over Torque Detection Disabled	0	-	
		1: Detected After the Setting Frequency			
		2: Detected When Running			
08-14	Over torque protection action	0: Stop Output After Over Torque Detection (Free Run to Stop)	0	-	
		1: Continue Running After Over Torque Detection (Display only OL3)			
08-15	Over Torque Detection Level	30~300	160	-	
08-16	Over Torque Detection Time	0.0~25.0	0.1	-	
08-17	Fire Mode	0: Disable	0	-	*5
		1: Enable			
08-18	Ground Fault Detection	0: Disable	0		
		1: Enable			

**Notes:** Regarding fire mode function, please refer to the conditions below,

1. Before the software rev. 1.1, the fire mode is functional when 08-17 = 1
2. After the software 1.1, the fire mode is functional when 03-00~03-05 = 【28】
3. The keypad display will indicate FIRE
4. Under fire mode function, the inverter will run at full speed

Group 09- Communication function setup					
No.	Description	Range	Factory Setting	Unit	Note
09-00	Assigned Communication Station Number	1 ~ 32	1	-	*2*3
09-01	RTU/ASCII Code Selection	0:RTU Code 1:ASCII Code	0	-	*2*3
09-02	Baud Rate Setting (bps)	0:4800 1:9600 2:19200 3:38400	2	bps	*2*3
09-03	Stop Bit Selection	0:1 Stop Bit 1:2 Stop Bits	0	-	*2*3
09-04	Parity Selection	0:Without Parity 1:With Even Parity 2:With Odd Parity	0	-	*2*3
09-05	Data Format Selection	0: 8-Bits Data 1: 7-Bits Data	0	-	*2*3
09-06	Communication Time-Out Detection Time	0.0 ~ 25.5	0.0	Sec	
09-07	Communication Time Out Operation Selection	0:Deceleration to Stop (00-15: Deceleration Time 1) 1:Coast to Stop 2:Deceleration to Stop (00-17: Deceleration Time 2) 3:Continue Operating	0	-	
09-08	Comm. Fault Tolerance Count.	1 ~ 20	3		
09-09	Wait Time of Inverter Transmission	5 ~ 65	5	ms	



Group 10- PID Function Setup					
No.	Description	Range	Factory Setting	Unit	Note
10-00	PID Target Value Selection (When 00-05\00-06=6 This Function is Enabled)	0: Potentiometer on Keypad 1: Analog Signal Input. (AI1) 2: Analog Signal Input. (AI2) 3: Frequency Set by Communication 4: Keypad Frequency Parameter 10-02	1	-	*1
10-01	PID Feedback Value Selection	0: Potentiometer on Keypad 1: Analog Signal Input. (AI1) 2: Analog Signal Input. (AI2) 3: Frequency Set by Communication	2	-	*1
10-02	PID Target(Keypad Input)	0.0~100.0	50.0	%	*1
10-03	PID Mode Selection	0: Disable 1: Deviation D Control. FWD Characteristic. 2: Feedback D Control FWD Characteristic. 3: Deviation D Control Reverse Characteristic. 4: Feedback D Control Reverse Characteristic.	0	-	
10-04	Feedback Gain Coefficient	0.00 ~ 10.00	1.00		*1
10-05	Proportional Gain	0.0 ~ 10.0	1.0		*1
10-06	Integral Time	0.0 ~ 100.0	10.0	Sec	*1
10-07	Derivative Time	0.00 ~ 10.00	0.00	Sec	*1
10-08	PID Offset	0: Positive 1: Negative	0	-	*1
10-09	PID Offset Adjust	0 ~ 109	0	%	*1
10-10	PID Output Lag Filter Time	0.0 ~ 2.5	0.0	Sec	*1
10-11	Feedback Loss Detection Mode	0: Disable 1: Enable - Drive Continues to Operate After Feedback Loss 2: Enable - Drive "STOPS" After Feedback Loss	0	-	
10-12	Feedback Loss Detection Level	0 ~ 100	0	%	
10-13	Feedback Loss Detection Delay Time	0.0 ~25.5	1.0	Sec	
10-14	Integration Limit Value	0 ~ 109	100	%	*1
10-15	Integral Value Resets to Zero when Feedback Signal Equals the Target Value	0: Disable 1: After 1 Second 30: After 30 Second (0~30)	0	-	
10-16	Allowable Integral value Error Margin (Units, 1 Unit = 1/8192)	0 ~ 100	0	-	
10-17	PID Sleep Frequency Level	0.00~650.00	0.00	Hz	
10-18	PID Sleep Function Delay Time	0.0 ~25.5	0.0	Sec	
10-19	PID Wake up frequency Level	0.00 ~ 650.00	0.00	Hz	
10-20	PID Wake up function Delay Time	0.0 ~ 25.5	0.0	Sec	
10-21	Max PID Feedback Setting Level	0 ~999	100	-	*1
10-22	Min PID Feedback Setting Level	0 ~999	0	-	*1

Group 11- Performance Control Functions					
No.	Description	Range	Factory Setting	unit	Note
11-00	Reverse Operation Control	0: Reverse Command is Enabled 1: Reverse Command is Disabled	0	-	
11-01	Carrier Frequency (kHz)	1~16	5	KHz	
11-02	Carrier Mode Selection	0: Mode0, 3Phase PWM modulation 1: Mode1, 2Phase PWM modulation 2: Mode2, 2Phase Random PWM Modulation	0	-	
11-03	Carrier Frequency Reduction by Temperature Rise	0:Disable 1:Enable	0	-	
11-04	S-Curve Acc 1	0.0 ~ 4.0	0.2	Sec	
11-05	S-Curve Acc 2	0.0 ~ 4.0	0.2	Sec	
11-06	S-Curve Dec 3	0.0 ~ 4.0	0.2	Sec	
11-07	S-Curve Dec 4	0.0 ~ 4.0	0.2	Sec	
11-08	Skip Frequency 1	0.00 ~ 650.00	0.00	Hz	*1
11-09	Skip Frequency 2	0.00 ~ 650.00	0.00	Hz	*1
11-10	Skip Frequency 3	0.00 ~ 650.00	0.00	Hz	*1
11-11	Skip Frequency Range Bandwith ( $\pm$ )	0.00 ~ 30.00	0.00	Hz	*1
11-12	Energy Saving Gain (V/F Mode)	0 ~ 100	80	%	
11-13	Regeneration Prevention Function	0:Disable 1:Enable 2:Enable (only during constant speed)	0	-	
11-14	Regeneration Prevention Voltage Level	200V:300.0~400.0	380.0	V	
		400V:600.0~800.0	760.0		
11-15	Regeneration Prevention Frequency Limit	0.00 ~ 15.00	3.00	Hz	
11-16	Regeneration Prevention Voltage Gain	0~200	100	%	
11-17	Regeneration Prevention Frequency Gain	0~200	100	%	

**Group 12 Digital Display & Monitor Functions**

No.	Description	Range	Factory Setting	Unit	Note
12-00	Extended Display Mode	00000~88888 Each digit can be set from 0 to 8 as listed below.	00000	-	*1
		0: Default Display (Frequency and Parameters)			
		1:Output Current			
		2:Output Voltage			
		3:DC Voltage			
		4:Temperature			
		5:PID Feedback			
		6:Analog Signal Input. (AI1)			
7:Analog Signal Input. (AI2)					
8:Count Status					
12-01	PID Feedback Display Format	0:Integer (xxx)	0	-	*1
		1:One Decimal Place (xx.x)			
		2:Two Decimal Places (x.xx)			
12-02	PID Feedback Display Unit Setting	0:xxx--	0	-	*1
		1:xxxpb(pressure)			
		2:xxxfl(flow)			
12-03	Custom Units (Line Speed) Value	0~65535	1500/1800	RPM	*1
12-04	Custom Units (Line Speed) Display Mode	0:Drive Output Frequency is Displayed	0	-	*1
		1:Line Speed.Integer.(xxxxx)			
		2:Line Speed.One Decimal Place. (xxxx.x)			
		3:Line Speed.Two Decimal Places (xxx.xx)			
		4:Line Speed.Three Decimal Places (xx.xxx)			
12-05	Inputs and Output Logic Status Display ( S1~S6, RY1 and RY2)	<p>The diagram shows a 6-digit display. The top row shows digits 1-6 with arrows pointing to labels S1, S2, S3, S4, S5, and S6. The bottom row shows digits 7-9 with arrows pointing to labels RY1, RY2, and PLC. The display shows '000000' in the top row and '000000' in the bottom row.</p>	-	-	*4
		<p>The diagram shows a 6-digit display. The bottom row shows digits 7-9 with arrows pointing to labels RY1, RY2, and PLC. The display shows '000000' in the bottom row.</p>			
12-06	Alarm Selections for Inverter Components Life Expectancy	xxxx0:Life Alarm of Inrush Current Suppression Circuit is Invalid	00000	-	*1
		xxxx1:Life Alarm of Inrush Current Suppression Circuit is Valid			
		xxx0x:Life Alarm of Control Circuit Capacitors is Invalid			
		xxx1x:Life Alarm of Control Circuit Capacitors is Valid			
xx0xx:Life Alarm of Main Circuit Capacitors is Invalid					
xx1xx:Life Alarm of Main Circuit Capacitors is Valid					

Group 12 Digital Display & Monitor Functions					
No.	Description	Range	Factory Setting	Unit	Note
12-07	Detect Main Circuit Capacitors	Reserved			
12-08	Display of Inrush Current Suppression Circuit	0~100	100	%	
12-09	Display of Control Circuit Capacitors	0~100	100	%	
12-10	Reserved				
12-11	Output Current when Fault Appeared	----	0	A	
12-12	Output Voltage when Fault Appeared	----	0	Vac	
12-13	Output Frequency when Fault Appeared	----	0	Hz	
12-14	DC Bus Voltage when Fault Appeared	----	0	Vac	
12-15	Frequency Command when Fault Appeared	----	0	Hz	

Group 13 Inspection & Maintenance Functions					
No.	Description	Range	Factory Setting	unit	Note
13-00	Drive Horsepower Code	----	-	-	*3
13-01	Software Version	----	-	-	*3*4
13-02	Fault Log (Latest 3 Faults)	----	-	-	*3*4
13-03	Accumulated Inverter Operation Time 1	0~23		hour	*3
13-04	Accumulated Inverter Operation Time 2	0~65535	----	day	*3
13-05	Accumulated Inverter Operation Time Mode	0: Power On time 1: Operation time	0	-	*3
13-06	Parameter Lock	0: Enable all Functions 1: Preset Speeds from 05-01 to 05-15 Can't be Changed 2: All Functions Can't be Changed Except for Preset speeds from 05-01 to 05-15 3: Disable All Functions Except 13-06	0	-	
13-07	Parameter Lock Code	00000~65535	00000	-	
13-08	Reset Drive to Factory Settings	1150: Reset to Factory Setting(50Hz System) 1160: Reset to Factory Setting(60 Hz System) 1112: Reset PLC	00000	-	

**Group 14 PLC Setting function**

No.	Description	Range	Factory Setting	unit	Note
14-00	Setting Value1 of T1	0~9999	0	-	
14-01	Setting Value1 of T1 (mode 7)	0~9999	0	-	
14-02	Setting Value1 of T2	0~9999	0	-	
14-03	Setting Value1 of T2 (mode 7)	0~9999	0	-	
14-04	Setting Value1 of T3	0~9999	0	-	
14-05	Setting Value1 of T3 (mode 7)	0~9999	0	-	
14-06	Setting Value1 of T4	0~9999	0	-	
14-07	Setting Value1 of T4 (mode 7)	0~9999	0	-	
14-08	Setting Value1 of T5	0~9999	0	-	
14-09	Setting Value1 of T5 (mode 7)	0~9999	0	-	
14-10	Setting Value1 of T6	0~9999	0	-	
14-11	Setting Value1 of T6 (mode 7)	0~9999	0	-	
14-12	Setting Value1 of T7	0~9999	0	-	
14-13	Setting Value1 of T7 (mode 7)	0~9999	0	-	
14-14	Setting Value1 of T8	0~9999	0	-	
14-15	Setting Value1 of T8 (mode 7)	0~9999	0	-	
14-16	Setting Value1 of C1	0~65535	0	-	
14-17	Setting Value1 of C2	0~65535	0	-	
14-18	Setting Value1 of C3	0~65535	0	-	
14-19	Setting Value1 of C4	0~65535	0	-	
14-20	Setting Value1 of C5	0~65535	0	-	
14-21	Setting Value1 of C6	0~65535	0	-	
14-22	Setting Value1 of C7	0~65535	0	-	
14-23	Setting Value1 of C8	0~65535	0	-	
14-24	Setting Value1 of AS1	0~65535	0	-	
14-25	Setting Value2 of AS1	0~65535	0	-	
14-26	Setting Value3 of AS1	0~65535	0	-	
14-27	Setting Value1 of AS2	0~65535	0	-	
14-28	Setting Value2 of AS2	0~65535	0	-	
14-29	Setting Value3 of AS2	0~65535	0	-	
14-30	Setting Value1 of AS3	0~65535	0	-	
14-31	Setting Value2 of AS3	0~65535	0	-	
14-32	Setting Value3 of AS3	0~65535	0	-	
14-33	Setting Value1 of AS4	0~65535	0	-	
14-34	Setting Value2 of AS4	0~65535	0	-	
14-35	Setting Value3 of AS4	0~65535	0	-	
14-36	Setting Value1 of MD1	0~65535	1	-	
14-37	Setting Value2 of MD1	0~65535	1	-	
14-38	Setting Value3 of MD1	1~65535	1	-	
14-39	Setting Value1 of MD2	0~65535	1	-	
14-40	Setting Value2 of MD2	0~65535	1	-	
14-41	Setting Value3 of MD2	1~65535	1	-	
14-42	Setting Value1 of MD3	0~65535	1	-	
14-43	Setting Value2 of MD3	0~65535	1	-	
14-44	Setting Value3 of MD3	1~65535	1	-	
14-45	Setting Value1 of MD4	0~65535	1	-	
14-46	Setting Value2 of MD4	0~65535	1	-	
14-47	Setting Value3 of MD4	1~65535	1	-	

Group 15 PLC Monitoring function					
No.	Description	Range	Factory Setting	unit	Note
15-00	Current Value of T1	0~9999	0	-	
15-01	Current Value of T1(mode 7)	0~9999	0	-	
15-02	Current Value of T2	0~9999	0	-	
15-03	Current Value of T2(mode 7)	0~9999	0	-	
15-04	Current Value of T3	0~9999	0	-	
15-05	Current Value of T3(mode 7)	0~9999	0	-	
15-06	Current Value of T4	0~9999	0	-	
15-07	Current Value of T4(mode 7)	0~9999	0	-	
15-08	Current Value of T5	0~9999	0	-	
15-09	Current Value of T5(mode 7)	0~9999	0	-	
15-10	Current Value of T6	0~9999	0	-	
15-11	Current Value of T6(mode 7)	0~9999	0	-	
15-12	Current Value of T7	0~9999	0	-	
15-13	Current Value of T7(mode 7)	0~9999	0	-	
15-14	Current Value of T8	0~9999	0	-	
15-15	Current Value of T8(mode 7)	0~9999	0	-	
15-16	Current Value of C1	0~65535	0	-	
15-17	Current Value of C2	0~65535	0	-	
15-18	Current Value of C3	0~65535	0	-	
15-19	Current Value of C4	0~65535	0	-	
15-20	Current Value of C5	0~65535	0	-	
15-21	Current Value of C6	0~65535	0	-	
15-22	Current Value of C7	0~65535	0	-	
15-23	Current Value of C8	0~65535	0	-	
15-24	Current Value of AS1	0~65535	0	-	
15-25	Current Value of AS2	0~65535	0	-	
15-26	Current Value of AS3	0~65535	0	-	
15-27	Current Value of AS4	0~65535	0	-	
15-28	Current Value of MD1	0~65535	0	-	
15-29	Current Value of MD2	0~65535	0	-	
15-30	Current Value of MD3	0~65535	0	-	
15-31	Current Value of MD4	0~65535	0	-	
15-32	Current Value of TD	0~65535	0	μs	



## 4.3 Parameter Function Description

### 00 - Basic Parameters Group

<b>00- 00</b>	<b>Control Mode Selection</b>
<b>Range</b>	<b>【0】 :V/F Mode</b> <b>【1】 :Vector Mode</b>

To select the appropriate vector or V/F control mode according to the load characteristics.

- If V/F mode is selected, please set parameters, group1 to comply with the load features.
- Vector is best suited to control the general load or rapidly-changed torque load.

<b>00- 02</b>	<b>Main Run Command Source Selection</b>
<b>Range</b>	<b>【0】 :Keypad</b> <b>【1】 :External Run/Stop Control</b> <b>【2】 :Communication</b> <b>【3】 :PLC</b>

- Parameter 00 - 02 sets the inverter operation command source. For switching between 00-02 and 00-03, use any of the external inputs S1 to S6 and set the relevant parameters (03-00~03-05) to **【12】**. Refer to parameter group3 for details.

※Note: 00- 02= **【3】** , **RUN key**: Enable the built-in PLC run operation; **STOP key**: Enable the built-in PLC stop operation.

<b>00- 03</b>	<b>Alternative Run Command Source Selection</b>
<b>Range</b>	<b>【0】 :Keypad</b> <b>【1】 :External Run/Stop Control</b> <b>【2】 :Communication</b>

- Parameter 00- 03 sets the inverter Alternative Run operation source. For switching between 00-02 and 00-03, use any of the external inputs S1 to S6 and set the relevant parameter (03-00~03-05) to **【12】** . Refer to parameter group3 for details.

<b>00- 04</b>	<b>Operation Modes for External Terminals</b>
<b>Range</b>	<b>【0】 :Forward/Stop-Reverse/Stop</b> <b>【1】 :Run/Stop- Reverse/ Forward</b> <b>【2】 :3 Wire Control Mode - Run/Stop</b>

- 00-04 is valid when run command is set to external mode by 00- 02/00- 03 =1.

#### **2 Wire Operation Mode,**

Set 00-04= **【0/1】** first, before setting (03-00,03-04) to **【0】** or **【1】**

00- 04= **【0】** , Set external terminals (03-00 to 03-05) function to 0 for FWD/Stop or Set to 1 for REV/Stop..

00- 04= **【1】** , Set external terminals (03-00 to 03-05) function to 0 for Run/Stop or Set to 1 for FWD/REV

#### **3 Wire Operation Mode,**

00-04 = **【2】** Terminals S1, S2, S3 are used in a combination to enable 3 wire run/stop mode.

Settings for 03-00, 03-01,03-02 will not be effective..(refer to group 03)

<b>00- 05</b>	<b>Main Frequency Command Source Selection</b>
<b>00- 06</b>	<b>Alternative Frequency Command Source Selection</b>
<b>Range</b>	<b>【0】 :Up/Down of Keypad</b> <b>【1】 :Potentiometer on Keypad</b> <b>【2】 :External AI1 Analog Signal Input</b> <b>【3】 :External AI2 Analog Signal Input</b> <b>【4】 :External Up/Down Frequency Control</b> <b>【5】 :Communication Setting Frequency</b> <b>【6】 :PID Output Frequency</b> <b>【7】 :Pulse Input</b>

- Parameter 00 - 05/00- 06 sets the inverter frequency command source.
- When 00-05/00-06 = **【6】** , frequency command source is output of the PID.

※Note: 00-05 ( Main Frequency Command Source) and 00- 06 (Alternative Frequency Command Source)

can not be the same. Otherwise the panel will display Err2.

<b>00- 07</b>	<b>Main and Alternative Frequency Command Modes</b>
<b>Range</b>	<b>【0】 : Main or Alternative Frequency. 【1】 : Main Frequency + Alternative Frequency</b>

- When 00 - 07 = **【0】** , the frequency source is set by the Main frequency parameter 00-05 ( Default) or by the Alternative frequency parameter 00-06.  
Use any of the external terminals S1 to S6 and set the relevant parameter 03-00 to 03-05 = **【13】** to switch from Main to Alternative source..
- When 00 - 07 = **【1】** , The frequency command will be the result of setting of main and alternative frequencies.

<b>00- 08</b>	<b>Communication Frequency Command</b>
<b>Range</b>	<b>【0.00~650.00】 Hz</b>

- This parameter can be used to set frequency command
- This parameter can be used to read the set frequency in communication mode
- This parameter is only effective in the communication mode.

<b>00- 09</b>	<b>Frequency Command save on power down (Communication mode)</b>
<b>Range</b>	<b>【0】 : Disable 【1】 : Enable</b>

- 00-09= **【0】** Keypad frequency is saved.
- 00-09= **【1】** Frequency set by communication is saved.

<b>00-10</b>	<b>Initial Frequency Selection</b>
<b>Range</b>	<b>【0】 :By Current Freq Command 【1】 :By Zero Freq Command 【2】 :By 00-11</b>

<b>00-11</b>	<b>Initial Frequency Setpoint</b>
<b>Range</b>	<b>【0.00~650.00】 Hz</b>

- This parameter is only effective in keypad mode
- When 00-10= **【0】** ,the initial frequency will be current frequency.
- When 00-10= **【1】** ,the initial frequency will be 0.
- When 00-10= **【2】** ,the initial frequency will be as set by parameter 00-11..

<b>00-12</b>	<b>Frequency Upper limit</b>
<b>Range</b>	<b>【0.01~650.00】 Hz</b>
<b>00-13</b>	<b>Frequency Lower limit</b>
<b>Range</b>	<b>【0.00~649.99】 Hz</b>

- When 00-13 and the command frequency are both set to 0.00, if RUN is pressed "Stpo" is displayed.
- When Frequency command is higher than preset in 00-13 inverter output will ramp up from 0.00 to the command frequency.
- When 00-13> 0, and the frequency command value ≤ 00-13, inverter output will ramp up from preset in lower limit to the command frequency.

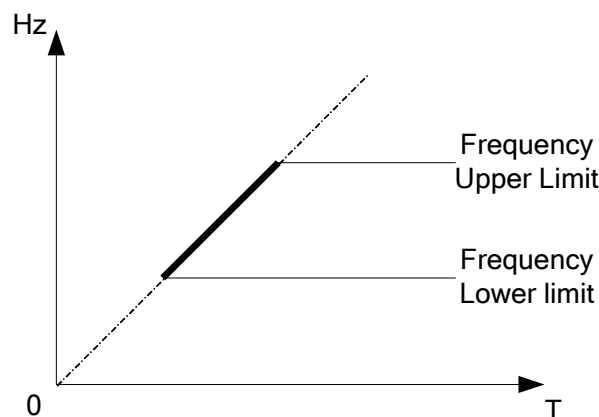

<b>00-14</b>	<b>Acceleration Time 1</b>
<b>Range</b>	<b>【0.1~3600.0】 s</b>
<b>00-15</b>	<b>Deceleration Time 1</b>
<b>Range</b>	<b>【0.1~3600.0】 s</b>
<b>00-16</b>	<b>Acceleration Time 2</b>
<b>Range</b>	<b>【0.1~3600.0】 s</b>
<b>00-17</b>	<b>Deceleration Time 2</b>
<b>Range</b>	<b>【0.1~3600.0】 s</b>

- Preset Acceleration and Deceleration times set by above parameters are the time taken for the output frequency to ramp up or ramp down between the Upper and the lower frequency limits.
- When 01-00=18, Maximum output frequency= the setting value of parameter 01-02;  
When 01-00≠18, Maximum output frequency =50.00 (or 60.00)
- Actual acceleration and deceleration time is calculated as follows:

$$\text{Actual acceleration time} = \frac{(00-14) \times (\text{set frequency} - \text{the minimum starting frequency})}{\text{Maximum output frequency}}$$

$$\text{Actual deceleration time} = \frac{(00-15) \times (\text{set frequency} - \text{the minimum starting frequency})}{\text{Maximum output frequency}}$$

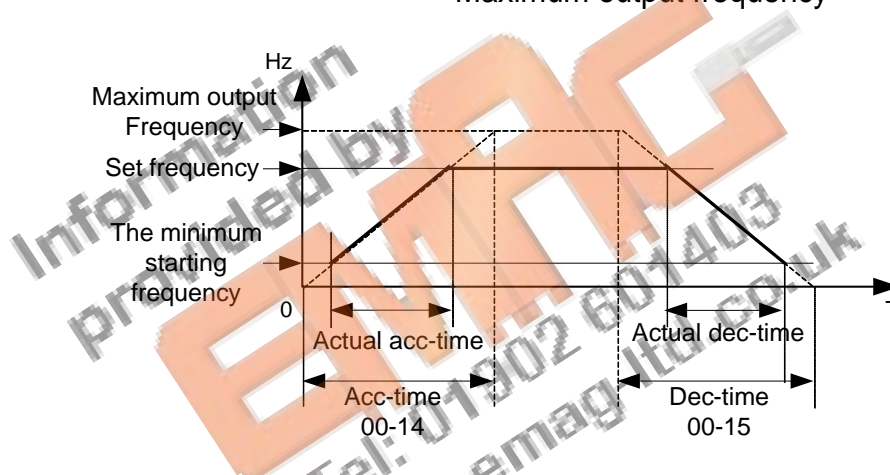

<b>00-18</b>	<b>Jog Frequency</b>
<b>Range</b>	<b>【0.00~650.00】 Hz</b>
<b>00-19</b>	<b>Jog Acceleration Time</b>
<b>Range</b>	<b>【0.1~3600.0】 Sec</b>
<b>00-20</b>	<b>Jog Deceleration Time</b>
<b>Range</b>	<b>【0.1~3600.0】 Sec</b>

- The JOG function is operational by using the multi-function input terminals S1 to S6 and setting the relevant parameters 03-00~03-05 to **【6】 JOG FWD** or **【7】 JOG REV**. Refer to parameter group 3.

## 01- V/F Pattern selections & setup

<b>01- 00</b>	<b>Volts/Hz Patterns (V/F)</b>
<b>Range</b>	<b>【0~18】</b>

- Set 01-00 to one of the following preset V/f selections 【0~17】 according to the required application.
- Parameters 01-02~01-09 are not applicable.
- Six fixed V/f patterns are shown below. 【1~8】 for 50 Hz systems and 【9~17】 for 60 Hz

TYPE	50Hz		60Hz	
Func tion	01-00	V/F pattern	01-00	V/F pattern
General Use	= 【0】		= 【9】	
High start torque	= 【1】 = 【2】 = 【3】		= 【10】 = 【11】 = 【12】	
Decreasing torque	= 【4】 = 【5】		= 【13】 = 【14】	
Decreasing torque	= 【6】 = 【7】 = 【8】		= 【15】 = 【16】 = 【17】	

(V) 100% is the maximum output voltage. B, C point preset % settings will be as table below:

01- 00	B(Xb)	C(Xc)
0 / 9	7.5%	4.5%
1 / 10	10.0%	7.0%
2	11.0%	8.5%
3	12.0%	9.5%
4	17.5%	4.0%
5	25.0%	5.0%
11	11.0%	8.0%
12	12.0%	9.0%
13	20.5%	7.0%
14	28.5%	8.0%
6 / 15	45.0%	1.0%
7 / 16	55.0%	1.0%
8 / 17	65.0%	1.0%

- Setting 01-00 = [18] provides a flexible V/F curve which can be selected by experienced users by setting parameters (01-02~01-09).

01- 01	<b>V/F Max Voltage</b>
Range	<b>【200V:170.0~264.0, 400V: 323.0~528.0】 V</b>
01- 02	<b>Maximum Frequency</b>
Range	<b>【0.20 ~ 650.00】 Hz</b>
01- 03	<b>Maximum Frequency Voltage Ratio</b>
Range	<b>【0.0 ~ 100.0】 %</b>
01- 04	<b>Medium Frequency 2</b>
Range	<b>【0.10 ~ 650.00】 Hz</b>
01- 05	<b>Medium Frequency Voltage Ratio 2</b>
Range	<b>【0.0 ~ 100.0】 %</b>
01- 06	<b>Medium Frequency 1</b>
Range	<b>【0.10 ~ 650.00】 Hz</b>
01- 07	<b>Medium Frequency Voltage Ratio 1</b>
Range	<b>【0.0 ~ 100.0】 %</b>
01- 08	<b>Minimum Frequency</b>
Range	<b>【0.10 ~ 650.00】 Hz</b>
01- 09	<b>Minimum Frequency Voltage Ratio</b>
Range	<b>【0.0 ~ 100.0】 %</b>

- Max output frequency depends on parameter 01-00 , for 01-00= **【18】** It can be set by parameter 01-02.
- For 01-00 ≠ **【18】** , the maximum output frequency will depending on parameter 00-12, frequency upper limit.

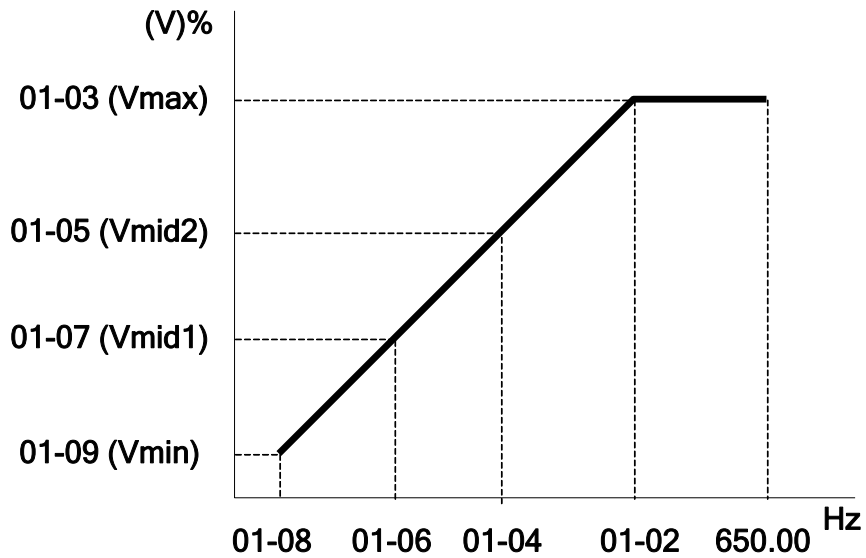

<b>01-10</b>	<b>Volts/Hz Curve Modification (Torque Boost)</b>
<b>Range</b>	<b>【0 ~ 10.0】 %</b>

- Inverter output V / F curve settings for points B, C can be adjusted by parameter 01-10 to improve the output torque.
- Calculation of B, C point voltage: B point voltage =  $X_b \times$  maximum output voltage, C point voltage =  $X_c \times$  maximum output voltage ( $X_b, X_c$  see P4-30). When 01-10 = 0, the torque improvement is disabled.

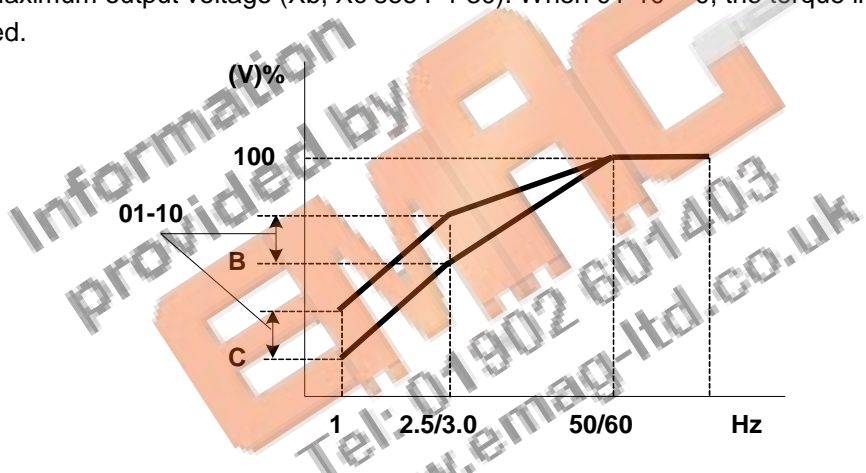

<b>01-11</b>	<b>V/F Start Frequency</b>
<b>Range</b>	<b>【0.00 ~10.00】 Hz</b>
<b>01-12</b>	<b>Slip Compensation Gain</b>
<b>Range</b>	<b>【0.05 ~10.00】 s</b>

V/F Start Frequency is for occasion where Start Frequency higher than zero Hz is needed.

<b>01-13</b>	<b>V/F Mode Select</b>
<b>Range</b>	<b>【0】 : Close Loop 【1】 : Open Loop</b>

- 0:** make use of CT to estimate motor speed, enhancing accuracy
- 1:** no estimation of motor speed; open loop control based on V/F curve.



## 02- Motor parameters

<b>02- 00</b>	<b>Motor No Load Current</b>
<b>Range</b>	<b>【0~ 【 (Parameter 02-01)-0.1】 】</b>
<b>02- 01</b>	<b>Motor Rated Current</b>
<b>Range</b>	<b>【0.2~100】</b>
<b>02- 02</b>	<b>Motor Rated Slip Compensation</b>
<b>Range</b>	<b>【0.0 ~ 200.0】 (%)</b>
<b>02- 03</b>	<b>Motor Rated Speed</b>
<b>Range</b>	<b>【0~39000】</b>

When the load causes the actual motor speed to be reduced below the speed set by inverter output frequency (Slip) , parameter 02-02 Slip compensation can be used to correct the speed.

$$\text{Slip compensation boost} = \frac{\text{Output Current}-(02-00)}{(02-01)-(02-00)} \times (02-02) \times \text{Rate motor slip}$$

Motor slip= Motor synchronization speed - Motor Rated Speed

$$(02-02)\text{approximate Value} = \frac{\text{Motor synchronization speed}-\text{Rated speed}}{\text{Motor synchronization speed}}$$

Motor synchronization speed (Marked on the motor nameplate)

$$\text{Motor synchronization speed(RPM)} = \frac{120}{\text{Motor Poles}} \times \text{Motor rate frequency(50/60Hz)}$$

Example: 4 poles, 60Hz induction motor synchronization speed =  $\frac{120}{4} \times 60 = 1800(\text{RPM})$

※Note: 02- 00/02- 01 differs with the inverter capacities (13- 00),It should be regulated according to actual conditions.

<b>02- 04</b>	<b>Motor Rated Voltage</b>
<b>Range</b>	<b>【200V: 170.0~264.0 / 400V: 323.0~528.0】</b>
<b>02- 05</b>	<b>Motor Rated Power</b>
<b>Range</b>	<b>【0.1~37.0】</b>
<b>02- 06</b>	<b>Motor Rated Frequency</b>
<b>Range</b>	<b>【0~650.0】</b>
<b>02- 07</b>	<b>Motor Pole Number</b>
<b>Range</b>	<b>【2~ 16】</b>
<b>02- 14</b>	<b>Auto Tune</b>
<b>Range</b>	<b>【0】 : Disable 【1】 : Enable</b>
<b>02- 15</b>	<b>Stator Resistance Gain</b>

<b>Range</b>	----
<b>02- 16</b>	<b>Rotor Resistance Gain</b>
<b>Range</b>	----

- In vector mode, selected by parameter 00-00= **【1】** , set the motor name plate data in parameters 02-01, 02-03~02-06 then activate the out auto tune function by setting parameter 02-14 = 1.
- Auto tune function will set the inverter to run with the specific motor connected to obtain the best motor performance.
- During the Auto tune. “AT” will be displayed on the inverter and there will be an automatic motor parameter measurements which will be stored in parameters 02-15~02-16.
- After successful auto tune function the display will return to command frequency display. Parameter 02-14 will reset to 0.
- Auto tune function must be carried out again if the motor is replaced.

### 03- External Digital Inputs and Relay Output Functions

<b>03- 00</b>	<b>Multifunction Input Term. S1</b>
<b>03- 01</b>	<b>Multifunction Input Term. S2</b>
<b>03- 02</b>	<b>Multifunction Input Term. S3</b>
<b>03- 03</b>	<b>Multifunction Input Term. S4</b>
<b>03- 04</b>	<b>Multifunction Input Term. S5</b>
<b>03- 05</b>	<b>Multifunction Input Term. S6</b>
<b>Range</b>	<p><b>【0】</b> :Forward/Stop Command----- (Parameters 00- 02/00-03=1&amp; 00-04)</p> <p><b>【1】</b> :Reverse/Stop Command----- (Parameters 00- 02/00-03=1&amp; 00-04)</p> <p><b>【2】</b> :Preset Speed 0 -----( Parameter (5- 02))</p> <p><b>【3】</b> :Preset Speed 1----- ( Parameter (5-03))</p> <p><b>【4】</b> :Preset Speed 2----- ( Parameter (5-05))</p> <p><b>【5】</b> :Preset Speed 3----- ( Parameter (5-09))</p> <p><b>【6】</b> :JOG Forward Command----- ( Parameters 00-18~00-20)</p> <p><b>【7】</b> :JOG Reverse Command----- ( Parameters 00-18~00-20)</p> <p><b>【8】</b> :Up Command----- ( Parameters 00- 05/00- 06=4&amp; 03-06/03-07)</p> <p><b>【9】</b> :Down Command----- ( Parameters 00- 05/00- 06=4&amp; 03-06/03-07)</p> <p><b>【10】</b> : 2<sup>nd</sup> Acc/Dec Times</p> <p><b>【11】</b> : Disable Acc/Dec</p> <p><b>【12】</b> : Main/ Alternative Run Source Select----( Parameters 00- 02/00- 03)</p> <p><b>【13】</b> : Main/ Alternative Frequency Command Select----( Parameters 00- 05/00- 06)</p> <p><b>【14】</b> : Rapid Stop (controlled deceleration stop)</p> <p><b>【15】</b> : Base Block (Coast to stop)</p> <p><b>【16】</b> : Disable PID Function -----( Parameter Goup10)</p> <p><b>【17】</b> : Reset</p> <p><b>【18】</b> : Enable Auto Run Mode----- ( Parameter Goup6)</p> <p><b>【19】</b> : Speed Search</p> <p><b>【20】</b> : Energy Saving(V/F)</p> <p><b>【21】</b> : Reset PID integral value to Zero</p> <p><b>【22】</b> : Counter Input</p> <p><b>【23】</b> : Counter Reset</p> <p><b>【24】</b> : PLC Input</p> <p><b>【25】</b> : Pulse Input-Width Measure (S3)</p> <p><b>【26】</b> : Pulse Input-Frequent Measure (S3)</p> <p><b>【27】</b> : Enable KEB Function</p> <p><b>【28】</b> : Fire mode function (Valid for software issued after rev. 1.1 )</p>

Set up examples and descriptions for Parameters 03-00 to 03-05 are noted in the following pages sections 1 to 13.

1. For setting parameters 03- 00~03- 05 to **【0, 1】** External Run/Stop Control, refer to 00- 04.

1A) 2-wire method. Mode 1.

Example: FWD/STOP and REV/STOP from two inputs ( S1&S2)

Set 00- 04= **【0】** ; S1:03- 00= **【0】** (FWD/STOP); S2:03- 01= **【1】** (REV/STOP);

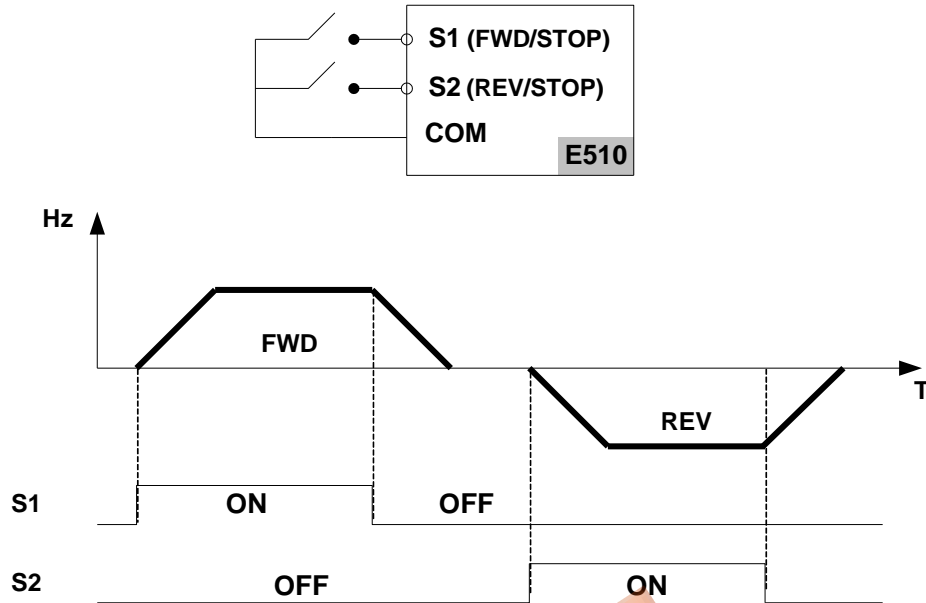

※**Note:** If both forward and reverse commands are ON, it will be treated as a STOP.

1B) 2-wire method. Mode 2.

Example: RUN/STOP and REV/FWD from two inputs (S1&S2)

Set 00- 04= **【1】** ; S1:03- 00= **【0】** (RUN/STOP); S2:03- 01= **【1】** (REV/FWD);

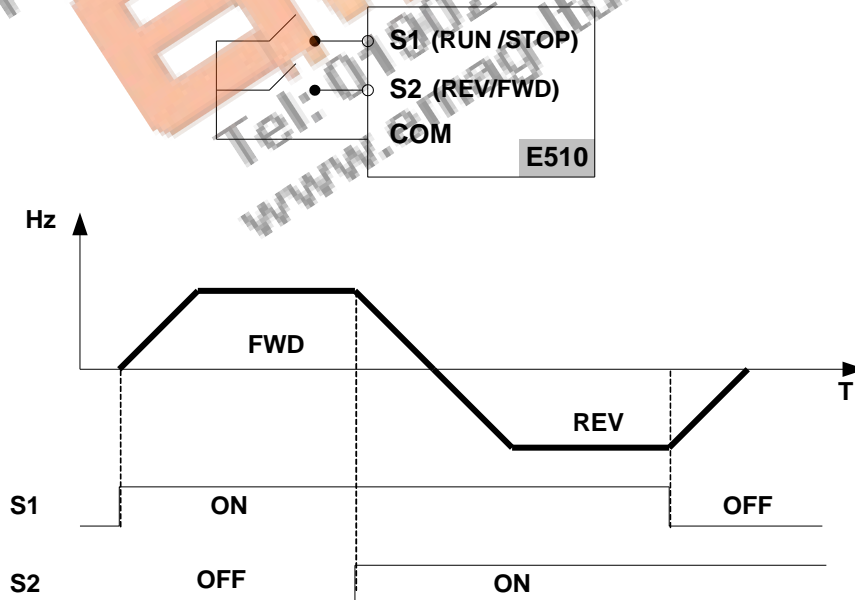

1C) 3-wire method.

Example:- Two separate push buttons for RUN & STOP and two position switch for FWD/ REV

Set 00- 04 =2. ( 3 wire control mode), then terminals S1, S2 and S3 are dedicated to this function and Preset selections for parameters 03-00, 03-01 and 03-02. are not relevant.

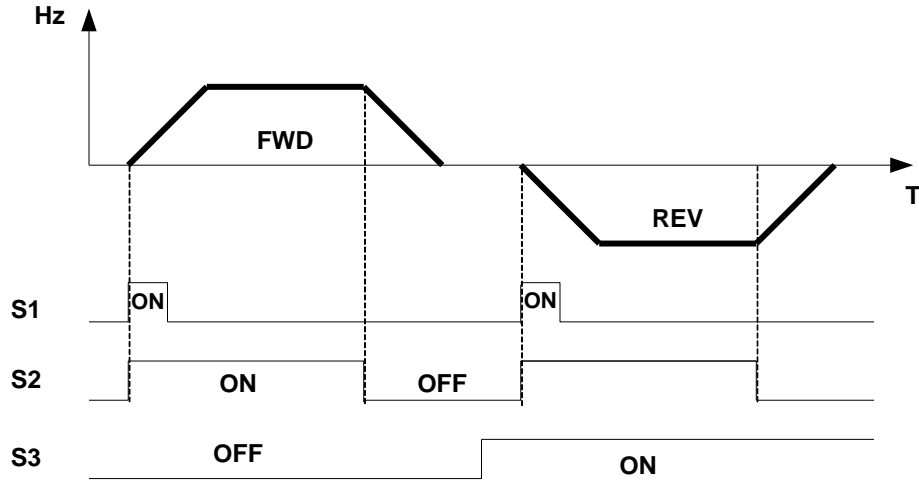
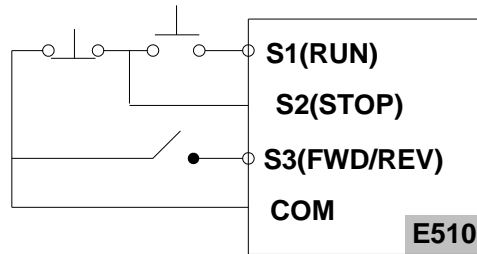

**2. 03- 00-03- 05= [ 5, 4, 3, 2 ] Preset speed selections**

Combination of any four terminals from S1~ S6 can be used to select preset speeds 0 to 15 according to the table below.

Preset speed 0-15 and the related acceleration/decelerating times should be set in parameter group 5.

For example timing diagram refer to Group 5 description

Preset speed	Function setting and state of any four (A, B, C,D) of terminal S1 ~ S6				Frequency	Acc-time	Dec-time
	terminal A=5	terminal B=4	terminal C=3	terminal D=2			
speed 0	OFF	OFF	OFF	OFF	05- 01	05- 17	05-18
speed 1	OFF	OFF	OFF	ON	05- 02	05- 19	05-20
speed 2	OFF	OFF	ON	OFF	05- 03	05- 21	05-22
speed 3	OFF	OFF	ON	ON	05- 04	05- 23	05-24
speed 4	OFF	ON	OFF	OFF	05- 05	05- 25	05-26
speed 5	OFF	ON	OFF	ON	05- 06	05- 27	05-28
speed 6	OFF	ON	ON	OFF	05- 07	05- 29	05-30
speed 7	OFF	ON	ON	ON	05- 08	05- 31	05-32
speed 8	ON	OFF	OFF	OFF	05- 09	05- 33	05-34
speed 9	ON	OFF	OFF	ON	05- 10	05- 35	05-36
speed 10	ON	OFF	ON	OFF	05- 11	05- 37	05-38
speed 11	ON	OFF	ON	ON	05- 12	05- 39	05-40
speed 12	ON	ON	ON	ON	05- 13	05- 41	05-42
speed 13	ON	ON	ON	ON	05- 14	05- 43	05-44
speed 14	ON	ON	ON	ON	05- 15	05- 45	05-46
speed 15	ON	ON	ON	ON	05- 16	05- 47	05-48

### 3. 03-00-03-05=【6,7】 Forward/ Reverse JOG

When an input terminal is set to function 【6】 and is turned on, inverter will work in jog forward mode.

When an input terminal is set to function 【7】 and is turned on, inverter will work in jog reverse mode.

Note: If jog forward and jog reverse function is enabled at the same time, inverter will enter stop mode.

### 4. 03-00-03-05=【8,9】 UP/DOWN

When an input terminal is set to function 【8】 and turned on, frequency command will increased according to the UP/DOWN and increment/decrement step set in parameter 03-06.

If the input is kept on continuously, the frequency command increases accordingly until the upper frequency limit is reached.

When an input terminal is set to function 【9】 and is turned on, frequency command decreases according to the UP/DOWN increment/decrement step set in parameter 03-06.

If the input is kept on continuously, the frequency command decreases accordingly and in relation to settings for parameter 03-06 and 3-07 until Zero speed is reached.

Refer to group 3 parameter description.

※Note: The UP/DOWN target frequency is determined by the time that the signal is kept on, including the acceleration /deceleration time.

### 5. 03-00-03-05=【10】 2<sup>nd</sup> Acc/Dec time

When an input terminal is set to function 【10】 and is turned on, the actual acceleration and deceleration time will be according to the time for 2<sup>nd</sup> Accel/Decel set in parameters 00-16 and 00-17.

if the input is turned off, the acceleration and deceleration times will be according to the default accel/decal 1 set in parameters 00-14 & 00-15.

Example: 00-12 (Frequency upper limit)=50HZ(Defaults)

03-00 (Terminal S1)= 8

03-06 (up/down frequency step)=0

00-14 (accelerating time 1)=5S

00-16 (accelerating time 2) =10S(Defaults)

When s1 is ON for 5 s, the actual accelerating time of inverter will be 2.5s.

Explain:

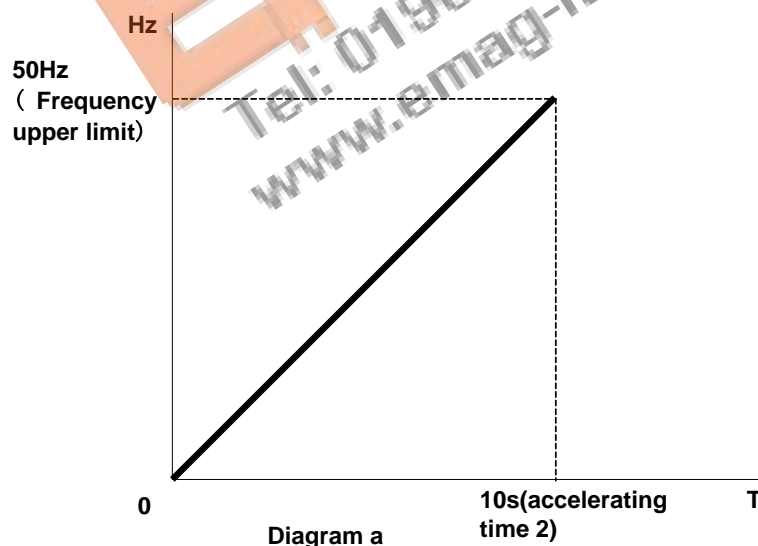

Diagram a: Target frequency is determined by the Frequency upper limit, the on-time and accelerating time 2..

$$\text{Target frequency} = \frac{\text{upper frequency}}{\text{accelerating time 2}} \times \text{on-time of S1} = \frac{50\text{Hz}}{10\text{S}} \times 5\text{S} = 25\text{Hz}$$

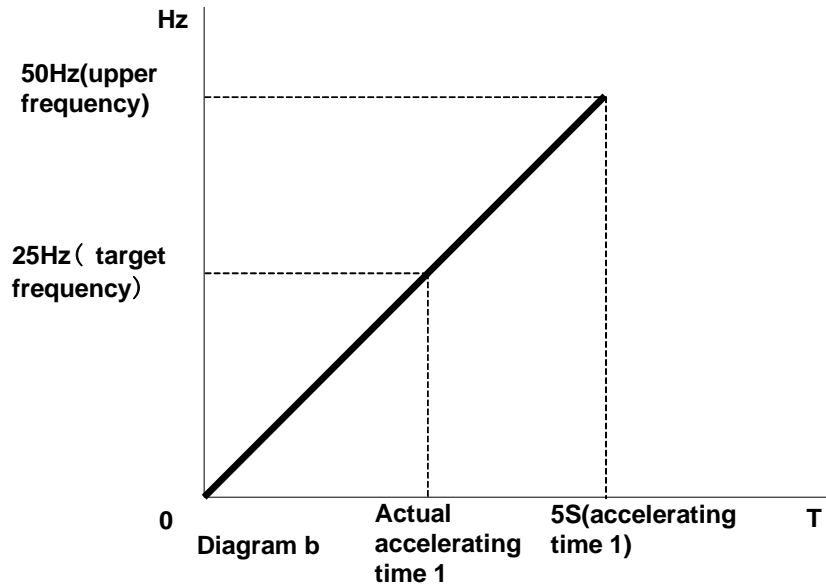

Diagram b: The actual accelerating time :

$$\text{actual accelerating time} = \frac{\text{target frequency}}{\text{upper frequency}} \times \text{accelerating time 1} = \frac{25\text{Hz}}{50\text{Hz}} \times 5\text{S} = 2.5\text{s}$$

**6. 03- 00-03- 05= 【11】 Disable Acc/Dec function**

When an input terminal is set to function 【11】 and is turned on, acceleration and deceleration function will be disabled and the frequency at the time is maintained. ( constant speed mode)  
If the input is turned off , acceleration and deceleration function is enabled again.

For an example see the following diagram.

Accel/Decel & Enable/Disable timing diagram using terminal S1 and parameter 03-00 = 11.

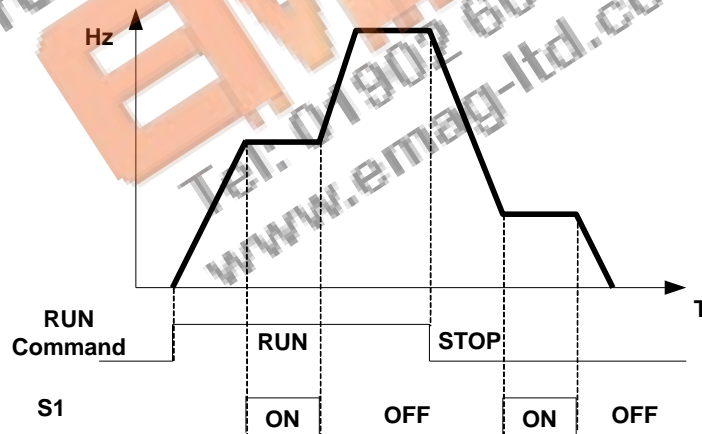

**7. 03- 00-03- 05= 【12】 Main/ / Alternative Run Source Select**

When an input terminal is set to function 【12】 and is turned on, the run command source is according to parameter 00-03(Alternative Run source).If the Input is off it will be according to 00-02 ( Main run source).

**8. 03- 00-03- 05= 【13】 Main/ Alternative Frequency Source Select**

When an input terminal is set to function 【13】 and is turned on, the frequency source is according to parameter 00-06(Alternative Frequency source).If the Input is off it will be according to 00-05 ( Main Frequency Source).

**9. 03- 00-03- 05= 【14】 Rapid Stop (controlled deceleration stop)**

When an input terminal is set to function 【14】 and is turned on , inverter decelerates to stop according to deceleration time 2.

**10. 03- 00-03- 05= 【15】 Base Block (Coast to stop)**

When an input terminal is set to function 【15】 and is turned on, inverter output is turned off.



### 11. 03-00-03-05=【16】Disable PID Function

When an input terminal is set to function 【16】 and is turned on, PID functions is disabled, if it is turned off , PID function is enabled again.

### 12. 03-00-03-05=【17】Reset

When a failure that can be manually reset occurs ,turn on a terminal with function 【17】 , the failure will be reset. (Same function as the Reset button on keypad).

### 13. 03-00-03-05=【18】Auto \_ Run Mode

When an input terminal is set to function 【18】 , the programmable auto- sequencer function is enabled, Refer to description of parameter group 6.

### 14. 03-00-03-05=【19】Speed Search Stop

When starting, the inverter detects the current speed of the motor, and then accelerates from the current speed to target speed.

### 15. 03-00-03-05=【20】Energy-saving operation

FAN, PUMP or other high inertia loads need greater starting torque, but once the operational speed is reached they need much less torque. In this mode the output voltage to the motor is reduced to match the required torque demand, hence providing a saving in energy.

The output voltage gradually declines as the input is ON. It will gradually increase (to the original voltage) when the input is OFF.

※Note: The acceleration and deceleration speed of energy saving operation is the same as the speed of speed search.

### 16. 03-00-03-05=【21】Reset PID Integral value to Zero

When input is engaged, PID integral value is reset to zero.

### 17. 03-00-03-05=【22】Counter Input

Use any of the multi-function inputs (S1 ~S6) and set the relevant parameter (03-00 ~03-05) to 22. Count Status can be displayed on the inverter by setting parameter 12-00 =8

Count display set  
by 12-00= 8

c0000 c0001 c0002 c0003 c0004 c0005 c0006 c0007

Count Input  
Multi-function input



### 18. 03-00-03-05=【23】Counter Reset

Counter counts can be reset to 0 at any time by using an external input connected to one of the multi-function inputs (S1~S6) and by setting the relevant parameter (03-00 ~03-05) to 23.

### 19. 03-00-03-05=【24】PLC Input

When anyone of the external terminals S1 to S6 set to 24 and turned on, the PLC program inputs will be enabled.

### 20. 03-02=【25】Pulse Input-Width Measure (S3)

When 03-02=25, S3 is the input port of pulse width measurement functions. Parameters setting and applying are as the followings:

00-05=7 ( Pulsed Speed Control )

03-27= 0.01~0.20KHz ( Pulse Input Frequency )

03-28=0.01~9.99 ( Inverter Frequency  $_F$ = duty cycle \* (00-12) \*(03-28) Hz , and below the Frequency Upper limit)

To adjust speed through pulse input duty cycle, set parameters as follows:

00-05=7; 03-02=25; 03-27=pulse input frequency; 03-28=1 (as per actual need)

When pulse input frequency is 200Hz, set 03-27=0.20 (must be correct). Along with the duty cycle of this 200Hz pulse input, inverter frequency is varied.

Example 1:

Pulse input frequency is 200Hz (03-27=0.20), duty cycle is 50%, frequency upper limit is 50Hz

(00-12=50.00), and 03-28=1

Inverter frequency is  $50\% \times 50.00 \times 1 = 25.00\text{Hz}$

Example 2:

Pulse input frequency is 100Hz (03-27=0.10), duty cycle is 30%, frequency upper limit is 50Hz (00-12=50.00), and 03-28=2

Inverter frequency is  $30\% \times 50.00 \times 2 = 30.00\text{Hz}$

Example 3:

Pulse input frequency is 100Hz (03-27=0.10), duty cycle is 15%, frequency upper limit is 650Hz (00-12=650.00), and 03-28=5

Inverter frequency is  $15\% \times 650.00 \times 5 = 487.50\text{Hz}$

**Note: In this mode, the frequency range of pulse input is 0.01 kHz to 0.20 kHz.**

### 21) 03- 02= 【26】 Pulse Input-Frequency Measure (S3)

When 03-02=26, S3 is the input port of the frequency measurement function. Parameters setting and applying are as the followings:

00-05=7 (Pulsed Speed Control)

03-02=26 (S3 is the pulse input- frequency measurement)

03-28=0.01~9.99

(Inverter Frequency  $_F=f*(3-28)$  Hz, and below the Frequency Upper limit.

f: Pulse Input Frequency.)

To adjust speed through pulse input frequency, set parameters as follows:

00-05=7; 03-02=26; 03-28=1 (as per actual need); 03-27 is not used.

Along with the pulse input frequency, inverter frequency is varied.

Example 1:

Pulse input frequency is 20Hz, frequency upper limit is 50Hz (00-12=50.00), and 03-28=1

Inverter frequency is 20.00Hz

Example 2:

Pulse input frequency is 45Hz, frequency upper limit is 50Hz (00-12=50.00), and 03-28=1

Inverter frequency is 45.00Hz

Example 3:

Pulse input frequency is 55Hz, frequency upper limit is 50Hz (00-12=50.00), and 03-28=1

Inverter frequency is 50.00Hz

Example 4:

Pulse input frequency is 200Hz, frequency upper limit is 650Hz (00-12=650.00), and 03-28=2

Inverter frequency is  $200 \times 2 = 400.00\text{Hz}$

**Note: In this mode, the frequency range of pulse input is 0.01 kHz to 0.20 kHz.**

※ Pulse input can only select S3 and when S3 is the terminal of pulse input, PLC output ground need to connect to COM from TM2.

**When 03-02 = 25 (Pulse Input -pulse width measurement), input configuration has to be NPN.**

**When 03-02 = 26 (Pulse Input - frequency measurement), input configuration can be either NPN or PNP.**

### 22) 03- 00-03- 05= 【27】 Enable KEB Function

Once the KEB enable input is activated the deceleration time to stop will be according to parameter 07-14.

### 23) 03- 00-03- 05= 【28】 Fire Mode Function

Fire Mode function can be used for applications where following a fire it is necessary for a motor to continue running, without interruption by the normal Inverter protection functions.

Example of such application is smoke extract fans used in buildings for fire evacuation.

#### Caution

- The correct use of this function is the responsibility of the installer of the fire safety system. Teco will bare no responsibility for direct or indirect damages or loss incurred as a result of use of this function.
- When inverter damage is caused by use of Fire Mode, inverter will lose its warranty.

Fire Mode function is enabled by setting parameter 08-17 = 1

- The fire Mode function is activated by using one of the external multifunction inputs S1 to S6 and setting the relevant parameter for the selected input by 03-00~03-05 = **【28】**
- Fire mode can also be enabled by setting the functions of S1 to S6 by communication method.
- Once Fire Mode is activated following takes place:-

1. The operator panel indicates FIRE, and the FIRE will be recorded in inverter fault log.
2. The inverter will run at full speed up to the maximum of inverter running frequency as set in 00-12, unless the main power is lost or cut off or the inverter itself breaks down.
3. When Fire Mode is activated, all protectional functions and alarms, such as ES, BB, OV, OC etc, will be ignored. STOP key on the operator panel becomes ineffective.
4. To reset fire mode: turn power off, remove fire mode input signal, and power on.

<b>03- 06</b>	<b>Up/Down Frequency Step</b>
<b>Range</b>	<b>【0.00~5.00】 Hz</b>

**Example: S1: 03- 00= 【8】 Up frequency command, S2: 03- 01= 【9】 Down frequency command, 03- 06= 【Δ】 Hz**

Mode1: UP or DOWN input terminals are turned on for less than 2 sec, for every On operation frequency changes by Δ Hz.

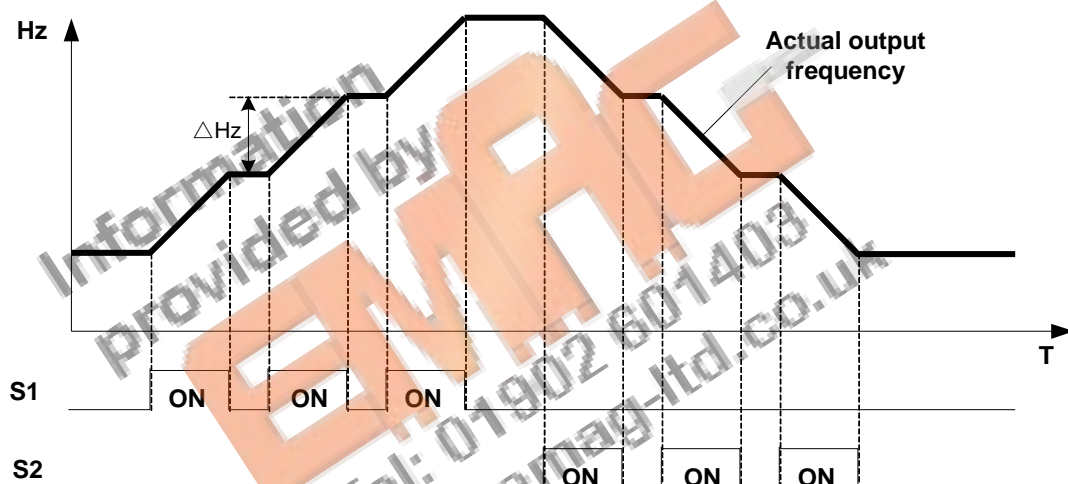

Mode 2: If UP or DOWN input terminals are turned on for more than 2 sec, the original UP/DOWN mode is restored output frequency ramps up or down as long as the input is kept ON.

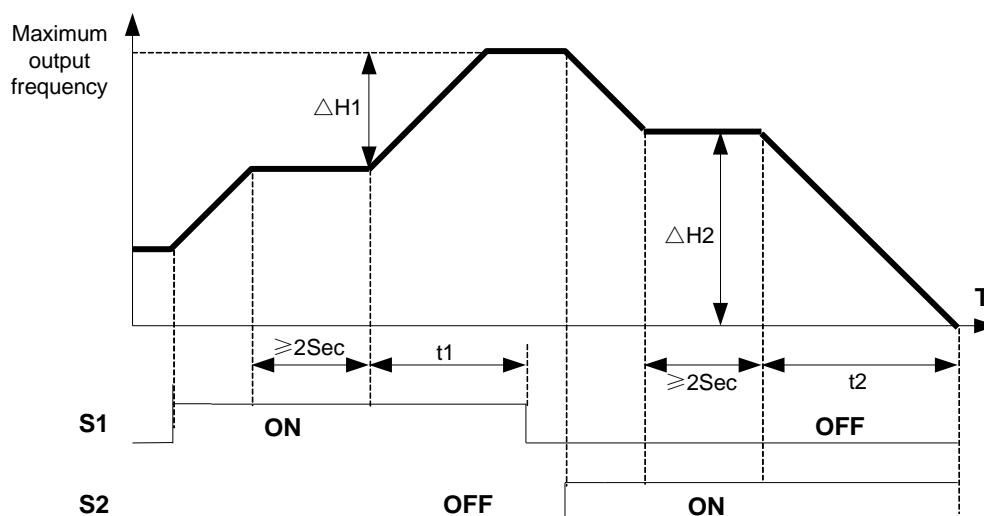

<b>03- 07</b>	<b>Up/Down Keep Frequency Status after Stop Command</b>
<b>Range</b>	<p><b>【0】</b> : After a stop command in Up/Down mode, the preset frequency is held as the inverter stops, and the UP/Down function is disabled.</p> <p><b>【1】</b> After a stop command in Up/Down mod, the preset frequency is reset to 0 Hz as the inverter stops.</p> <p><b>【2】</b>: After a stop command in Up/Down mode,, the preset frequency is held as the inverter stops, and the UP/Down function remains enabled.</p>

- 03 - 07 = **【0】** , When run signal is removed (Stop Command), the output frequency is stored in parameter 05-01( Key pad Frequency).
- 03 - 07 = **【0】** In stop mode since frequency can not be increased or decreased from Up/Down terminals then keypad can be used to change the frequency by modifying parameter 05-01.
- Set 03 - 07 = **【1】** , In Up/down frequency mode inverter will ramp up from 0Hz on Run command and Ramp down to 0 Hz on stop command.

<b>03- 08</b>	<b>Multifunction terminals S1~S6 scan time</b>
<b>Range</b>	<b>【1~200】 2ms</b>

- Multifunction input terminal On/Off periods will be scanned for the number of cycles according to the set value in parameter 03-08. If the signal status for ON or OFF period is less than the set period it will be treated as noise.
- Scan period unit is 2ms.
- Use this parameter if unstable input signal is expected, however setting long scan time periods results in slower response times.

※Note: Terminal SF is for safety switch, SF can cut off the inverter voltage output.

<b>03- 09</b>	<b>S1~S5 Input Type Selection NO &amp; NC</b>
<b>Range</b>	<p><b>【xxxx0】</b> :S1 NO      <b>【xxxx1】</b> :S1 NC</p> <p><b>【xxx0x】</b> :S2 NO      <b>【xxx1x】</b> :S2 NC</p> <p><b>【xx0xx】</b> :S3 NO      <b>【xx1xx】</b> :S3 NC</p> <p><b>【x0xxx】</b> :S4 NO      <b>【x1xxx】</b> :S4 NC</p> <p><b>【0xxxx】</b> :S5 NO      <b>【1xxxx】</b> :S5 NC</p>
<b>03- 10</b>	<b>S6 Input Type Selection NO &amp; NC</b>
<b>Range</b>	<b>【xxxx0】</b> :S6 NO <b>【xxxx1】</b> :S6 NC

- “NO”: Normally open, “NC”: Normally closed. . Select as required
- For selecting Normally Open (NO) or Normally Closed (NC) set the relevant digit in parameter 03-09/03-10 to 0 or 1 as required.
- In order to enable parameters 03-09/03-10, please set 03-20 = 1 (internal control) beforehand.
- Set Parameter 03-09 first before you use the Parameters 00-02/00-03=1 to set the inverter run mode to External multifunction inputs.
- For example, to select S1,S2 as NC, while S3,S4,S5 as NO, set 03-09 = 00011

<b>03-11</b>	<b>Multifunction Output Relay RY 1 functions. ( Terminals R1C,R1B, R1A )</b>
<b>03-12</b>	<b>Multifunction Output Relay RY 2 functions. ( Terminals R2B, R2A )</b>
<b>Range</b>	<p><b>【0】</b> :Run</p> <p><b>【1】</b> :Fault</p> <p><b>【2】</b> :Set Frequency within the preset range. -----( refer to 03-14)</p> <p><b>【3】</b>:Set Frequency reached. As set by (3-13±3-14) ----- ( refer to 03-13/03-14)</p> <p><b>【4】</b> :Output Frequency Detection 1 (&gt; 03-13) -----( refer to 03-13)</p> <p><b>【5】</b> :Output Frequency Detection 2 (&lt; 03-13) -----( refer to 03-13)</p> <p><b>【6】</b> :Auto-restart</p> <p><b>【7】</b> :Momentary AC Power Loss----- ( refer to 07-00)</p> <p><b>【8】</b> :Rapid Stop ( Decelerate to Stop)</p> <p><b>【9】</b> :Base Block Stop Mode</p> <p><b>【10】</b> :Motor Overload Protection (OL1)</p> <p><b>【11】</b> :Drive Overload Protection (OL2)</p> <p><b>【12】</b> :Over Torque Threshold Level (OL3)</p> <p><b>【13】</b> :Preset Current level Reached ----- ( refer to 03-15/03-16)</p> <p><b>【14】</b> :Preset Brake Frequency Reached ----- (refer to 03-17/03-18)</p>

	<b>【15】 :PID Feedback Signal Loss</b> <b>【16】 :Single pre-set count (3-22)</b> <b>【17】 :Dual pre-set count (3-22~23)</b> <b>【18】 :PLC status indicator (00-02)</b> <b>【19】 :PLC control</b> <b>【20】 :Zero Speed</b>
<b>03-13</b>	<b>Frequency Reached Level</b>
<b>Range</b>	<b>【0.00~650.00】 Hz</b>
<b>03-14</b>	<b>Frequency Reached Detection Range (±)</b>
<b>Range</b>	<b>【0.00~30.00】 Hz</b>

**Output relay RY function descriptions:**

- 1) 03-11/03-12 = **【0】** . RY will be ON with Run signal.
- 2) 03-11/03-12 = **【1】** . RY will be ON with inverter Faults.
- 3) 03-11/03-12 = **【2】** . RY will be ON when Preset frequency (03-13) – Preset frequency Detection Range (03-14) is reached.

When Output Freq. = Preset Freq. Reached Setting (03-13) - Preset Freq. Reached Detection Range (03-14), Relay Output will be ON

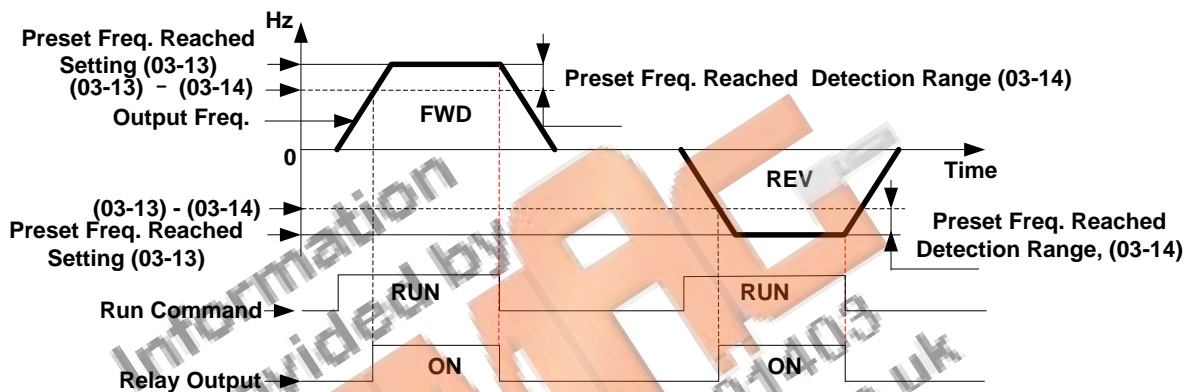

Example: Sets 03-13=30 and 03-14=5, Relay will ON when output frequency reached 25Hz to 30Hz.

- 4) 03-11= **【3】** .RY will be ON when preset frequency level (03-13) +/- preset Frequency Detection Range (03-14) is reached.



When, Freq. Detection Range Lower Limit < Setting Freq. < Freq. Detection Range Upper Limit  
 And, Detection Range Lower Limit < Output Freq. < Freq. Detection Range Upper Limit,  
 Relay output will be ON (Allowable tolerance  $\pm 0.01$ )

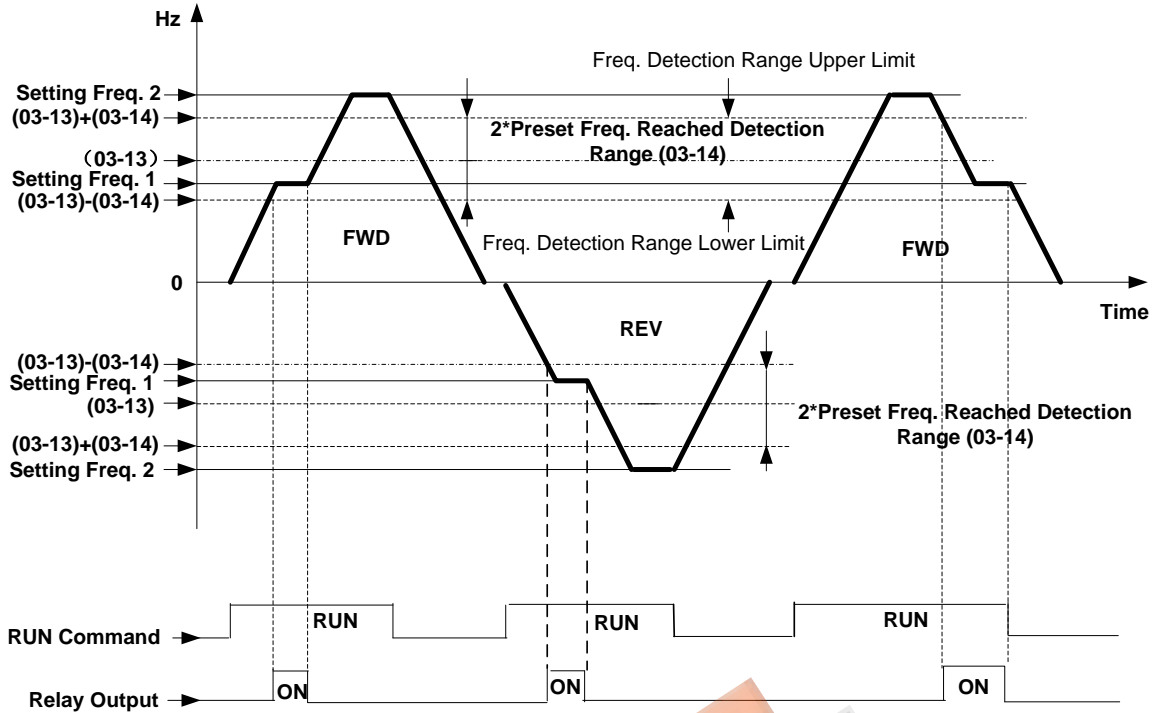

5) 03-11= **【4】** . RY will be on as soon as the output frequency > preset frequency reached Setting (03-13)

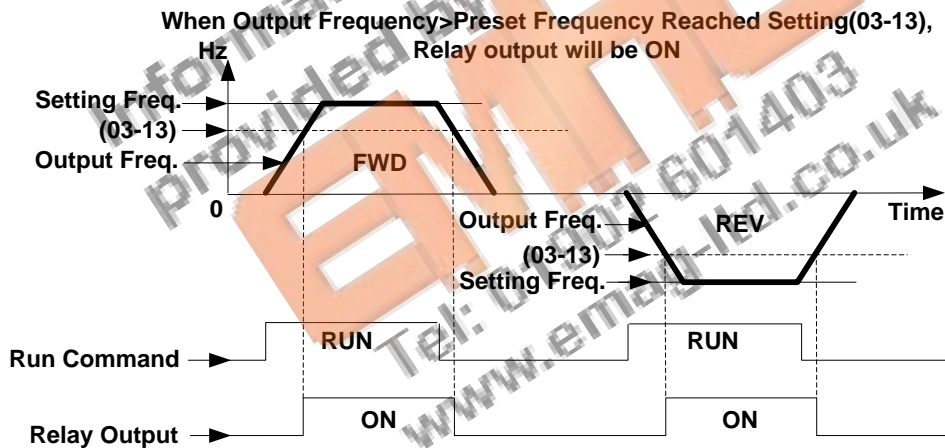

6) 03-11= **【5】** . RY will be on as soon as the output frequency < Preset Frequency Reached Setting (03-13)

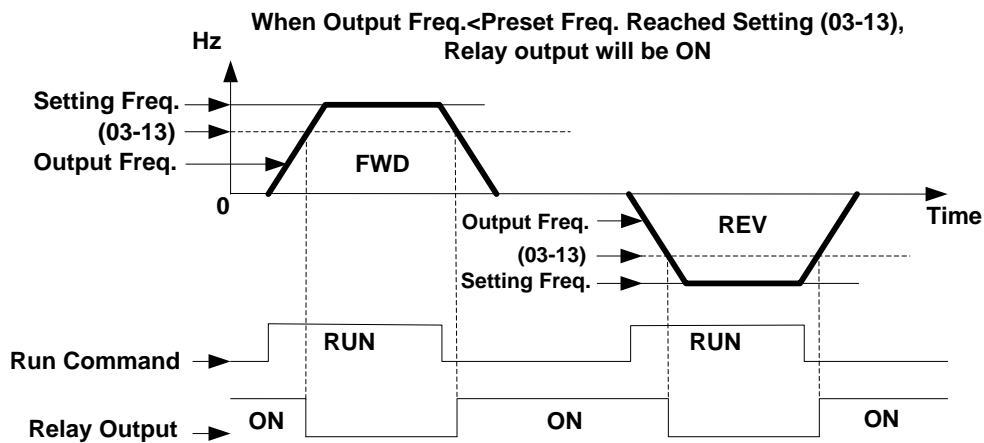



7) 03-11/03-12= 【20】 Zero Speed

Off	Output Frequency => Minimum Frequency (01-08,Fmin)
On	Output Frequency < Minimum Frequency (01-08,Fmin)

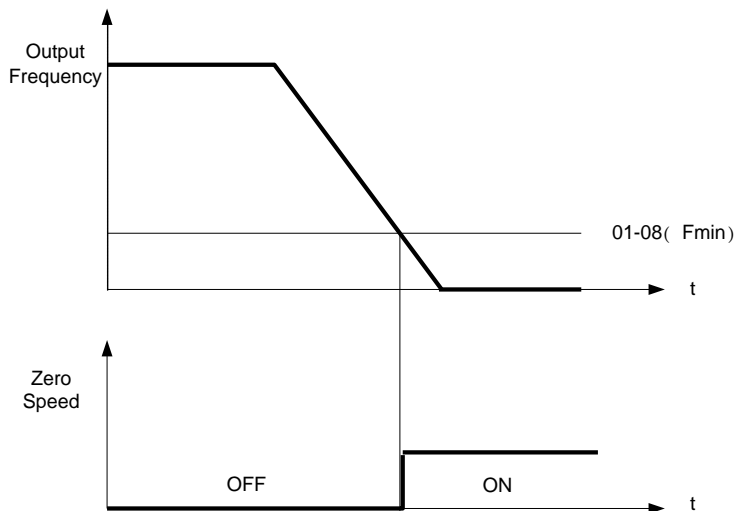

03-15	Preset output current reached
Range	【0.1~15.0】 A
03-16	Preset output Current detection delay Time
Range	【0.1~10.0】 Sec

- 03-11= 【13】 RY1 will be on as soon as the output current value > preset current setting (03-15).
- 03-15: Setting range (0.1~15.0 Amps ) as required according to the rated motor current.
- 03-16: Setting range (0.1~10.0) unit: seconds

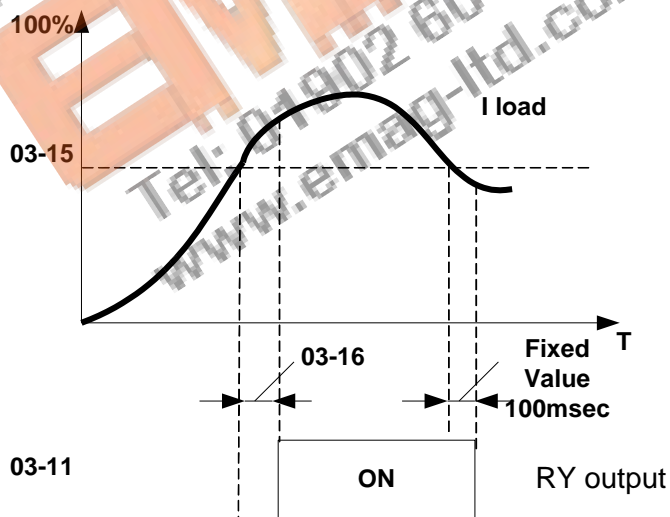

03-17	Brake Release Level
Range	【0.00~20.00】 Hz
03-18	Brake Engage Level
Range	【0.00~20.00】 Hz

- If 03-11 = 【14】
- In accelerating mode, RY will be ON as soon as the actual output frequency reaches the external Brake release level set in parameter 03-17.
- In decelerating mode, RY will be OFF as soon as the actual output frequency reaches the external Brake engage level set in parameter 03-18.



Timing diagram for  $03-17 \leq 03-18$  is shown below:

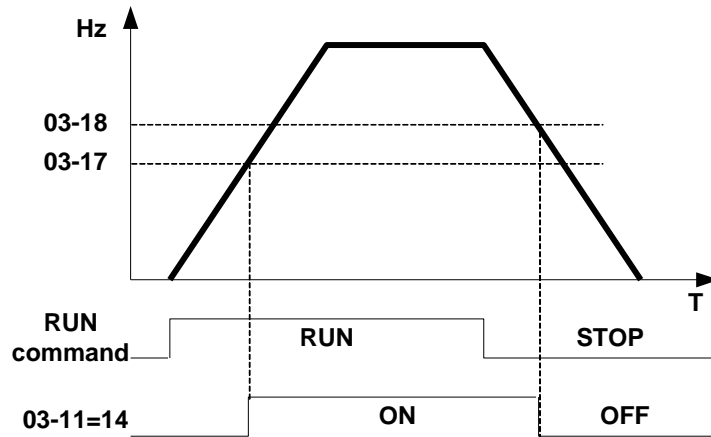

Timing diagram for  $03-17 \geq 03-18$  is shown below:

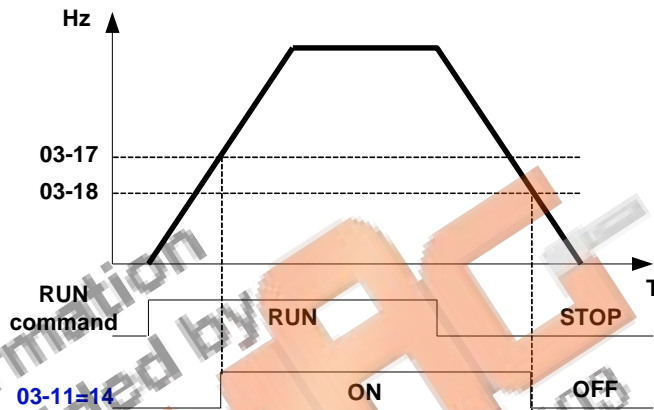

<b>03- 19</b>	<b>Relay Output Status Type</b>
<b>Range</b>	<b>【0】 :A (Normally open)</b> <b>【1】 :B (Normally close)</b>

- When 03-19=0,
- When the set conditions of 03-11,03-12 are met , relay contact is closed, otherwise it will be open..
- When 03-19=1,
- When the set conditions of 03-11,03-12 are met ,relay contact will open,Otherwise it will be closed.

<b>03- 20</b>	<b>Internal / External Multi-Function Input Terminal Selection</b>
<b>Range</b>	<b>【0-63】</b>
<b>03- 21</b>	<b>Action to Set the Internal Multi-Function Input Terminals</b>
<b>Range</b>	<b>【0-63】</b>

- Parameter 03-20 determines if external/ internal control for multi-function inputs S1-S6 is selected. The corresponding contact is set to 1 when internal multi-tunction input is selected and it is set to 0 when the external one is selected.
- The input selection is according to the decimal value set.

DI	S6	S5	S4	S3	S2	S1
<b>Binary</b>	$2^5$	$2^4$	$2^3$	$2^2$	$2^1$	$2^0$
<b>Decimal</b>	<b>32</b>	<b>16</b>	<b>8</b>	<b>4</b>	<b>2</b>	<b>1</b>

**The definition of bits in 03-20:**

03- 20= 0   0   0   0   0   0  
          S6   S5   S4   S3   S2   S1

**0:** external control according to 03-00 to 03-05.

**1:** internal ON/OFF status control according to 03-21.

**The definition of bits in 03-21:**

03- 21= 0   0   0   0   0   0  
          S6   S5   S4   S3   S2   S1

**0:** internal multi-function input terminal is OFF.

**1:** internal multi-function input terminal is ON.

For example, it is required to set the ON/OFF status of terminals S2, S4, S6 internally.

1. Set 03-20 = 42 (2+8+32) to select S2, S4, and S6, which is binary 101010.
2. Set 03-21 = 10 (2+8), which is binary 001010, meaning S2 and S4 are ON.

Information  
provided by  
**EMAG**  
Tel: 01902 601403  
[www.emag-ltd.co.uk](http://www.emag-ltd.co.uk)

<b>03- 22</b>	<b>Pre-set count 1</b>
<b>Range</b>	<b>【0~9999】</b>
<b>03- 23</b>	<b>Pre-set count 2</b>
<b>Range</b>	<b>【0~9999】</b>

- The internal counter function can be used to count external pulses and activate RY1 & RY2 output relays to indicate the pre-set counts reached set in parameters 03-22 & 03-23.
- Internal counter counts can be checked against a single pre-set value or a dual pre-set value.
- For **single pre-set count**, set parameter 03-22 to the required pre-set count.

To activate relays RY1 or RY2 for a single pre-set count set parameter 03-11 (RY1) or 03-12 (RY2) as required to 16.

Pulse inputs at the selected terminal will increment the internal counter until the pre-set count in parameter 03-22 is reached then the selected Ry1 or Ry2 relay will be **turned ON**.

Removing the input signal when the pre-set count is reached the counter is reset to zero and the selected relay will be **turned off**.

- For **Dual pre-set count**, set 03-23 to **turn ON** the selected relay and Set parameter 03-22 to **turn off** the selected Relay.

To activate relays RY1 or RY2 for a Dual pre-set count set parameter 03-11 (RY1) or 03-12 (RY2) as required to 17.

Pulse inputs at the selected terminal will increment the internal counter until the pre-set count in parameter 03-23 is reached then the selected Ry1 or Ry2 relay will be turned ON. Then as the pulse input is continued, the counts will be incremented until the pre-set count set in parameter 03-22 is reached as soon as the input pulse is removed the counter is rest to zero and the selected Relay is turned off.

03-22 pre-set value must be  $\geq$  pre-set value of 03-23

➔ Example diagram for single&dual preset counts using RY1&RY2

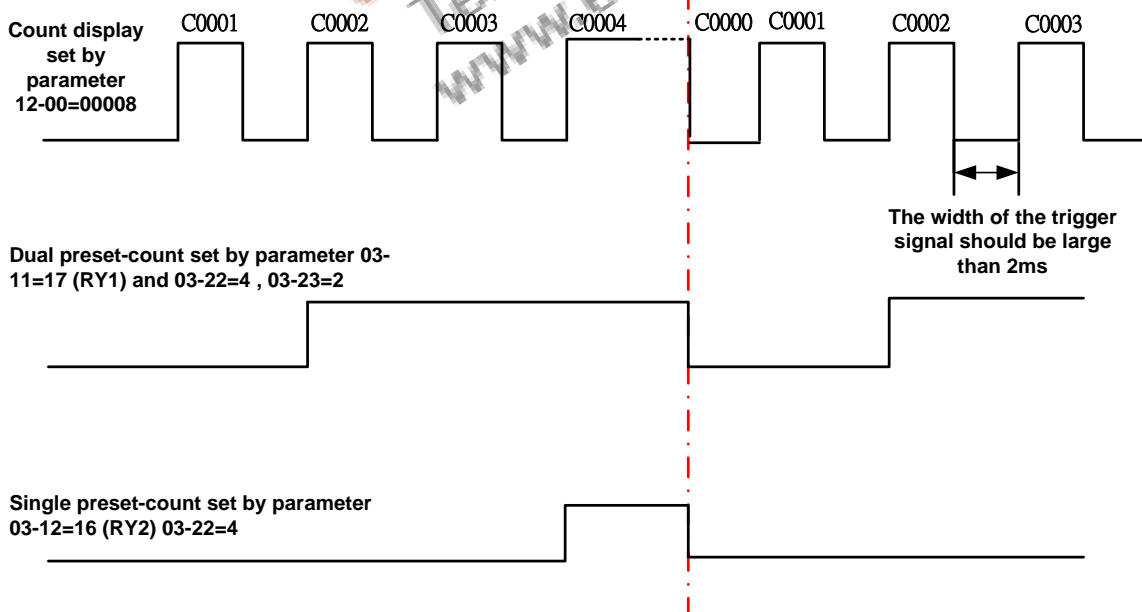

<b>03- 24</b>	<b>Output Under Current Detection</b>
<b>Range</b>	<b>【0】 :disable 【1】 :enable</b>
<b>03- 25</b>	<b>Output Under Current Detection Level</b>
<b>Range</b>	<b>【5%~100%】</b>
<b>03- 26</b>	<b>Output under Current Detection Delay Time</b>
<b>Range</b>	<b>【0.0~50.0s】</b>

- When 03-24 = 1, if output current is less than under current detection level, for a preset time 03-26 then ud-C fault will be displayed.

<b>03- 27</b>	<b>Pulse Frequency</b>
<b>Range</b>	<b>【0.01~0.20】</b>
<b>03- 28</b>	<b>Pulse Frequency Gain</b>
<b>Range</b>	<b>【0.01~9.99】</b>

Information  
provided by  
**EMAG**  
Tel: 01902 601403  
[www.emag-ltd.co.uk](http://www.emag-ltd.co.uk)

## 04- External Analog Signal Input / Output Functions

04- 00	Analog Voltage & Current Input Selections AI1/AI2	
Range	AI1	AI2
	<b>【0】</b> : 0~10V (0~20mA)	0~10V (0~20mA)
	<b>【1】</b> : 0~10V (0~20mA)	2~10V (4~20mA)
	<b>【2】</b> : 2~10V (4~20mA)	0~10V (0~20mA)
	<b>【3】</b> : 2~10V (4~20mA)	2~10V (4~20mA)

➤ Use JP2/JP3 to set analog signal type to voltage or current input. Parameter 04-00 must be set according to JP2/JP3 setting.

➤ Analog input scaling formula as shown below.

### ■ Current Input Mode

$$AI (0\sim 20mA) : F (Hz) = \frac{I (mA)}{20(mA)} \times (00 - 12)$$

$$AI (4\sim 20mA) : F (Hz) = \frac{I - 4(mA)}{20 - 4(mA)} \times (00 - 12), I \geq 4$$

### ■ Voltage Input Mode

$$AI (0\sim 10V) : F (Hz) = \frac{V(v)}{10(v)} \times (00 - 12)$$

$$AI(2\sim 10V) : F (Hz) = \frac{V - 2(v)}{10 - 2(v)} \times (00 - 12), V \geq 2$$

04- 01	AI1 Signal Verification Scan Rate
Range	<b>【1~200】</b> 2msec
04- 02	AI1 Gain
Range	<b>【0 ~ 1000】</b> %
04- 03	AI1 Bias
Range	<b>【0~ 100】</b> %
04- 04	AI1 Bias Selection
Range	<b>【0】</b> : Positive <b>【1】</b> : Negative
04- 05	AI1 Slope
Range	<b>【0】</b> : Positive <b>【1】</b> : Negative
04- 06	AI2 signal verification Scan Rate
Range	<b>【1~200】</b> 2msec
04- 07	AI2 Gain
Range	<b>【0 ~ 1000】</b> %
04- 08	AI2 Bias
Range	<b>【0 ~ 100】</b> %
04- 09	AI2 Bias Selection
Range	<b>【0】</b> : Positive <b>【1】</b> : Negative
04-10	AI2 Slope
Range	<b>【0】</b> : Positive <b>【1】</b> : Negative

➤ Set 04- 01 and 04- 06 for analog signal verification.

Inverter reads the average values of A/D signal once per (04- 01/04- 06 x 2ms). Set scan intervals according to the application and with consideration for signal instability or interference effects on the signal by external sources. Long scan times will result in slower response time.



(1) **Positive Bias type** (04-04= 0) and effects of modifying Bias amount by parameter 04-03 and Slope type with parameter 04-05 are shown in Fig 1&2.

Figure1:

	04- 02	04- 03	04- 04	04- 05
A	100%	50%	0	0
B	100%	0%	0	0

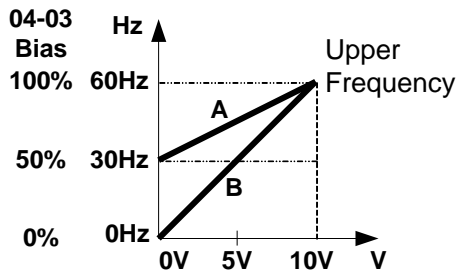
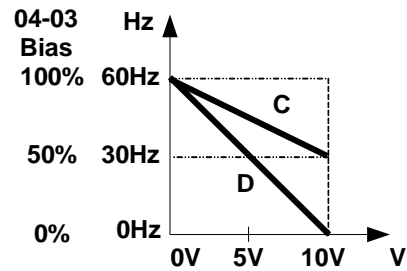

Figure2:

	04- 02	04- 03	04- 04	04- 05
C	100%	50%	0	1
D	100%	0%	0	1



(2)**Negative Bias type** and effects of modifying Bias amount by parameter 04-03 and Slope type with parameter 04-05 are shown in Fig 3&4.

Figure3:

	04- 02	04- 03	04- 04	04- 05
E	100%	20%	1	0

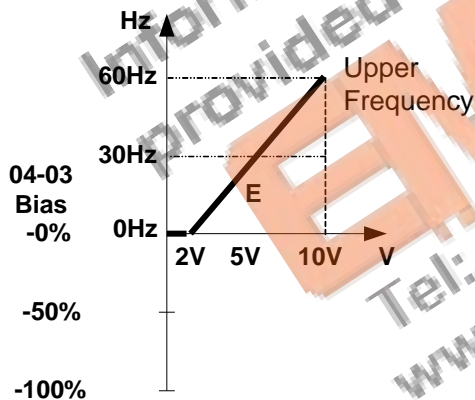
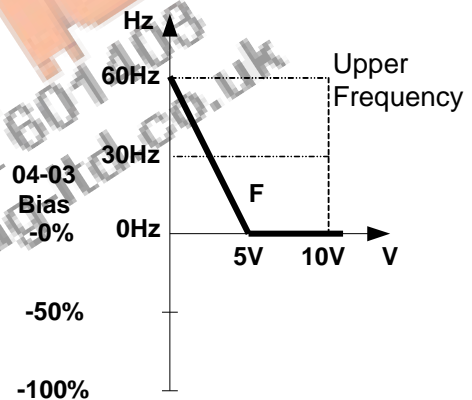

Figure4:

	04- 02	04- 03	04- 04	04- 05
F	100%	50%	1	1



(3) Offset bias set to 0% (04-03) and effect of modifying Analog Gain (04-02), Bias type (04-04) and slope type (04-05) are shown in shown Fig 5&6.

Figure5:

	04- 02	04- 03	04- 04	04- 05
A'	50%	0%	0/1	0
B'	200%	0%	0/1	0

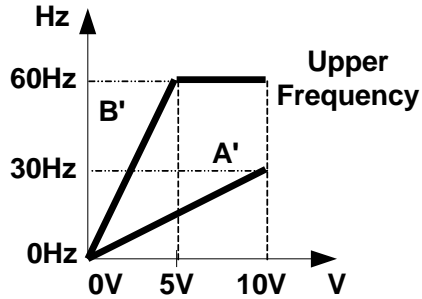
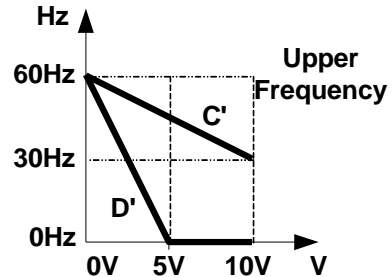

Figure6:

	04- 02	04- 03	04- 04	04- 05
C'	50%	0%	0/1	1
D'	200%	0%	0/1	1



(4) Various other examples of analog input scaling and modification are shown in following figures 7,8,9 & 10.

Figure7:

	04- 02	04- 03	04- 04	04- 05
a	50%	50%	0	0
b	200%	50%	0	0

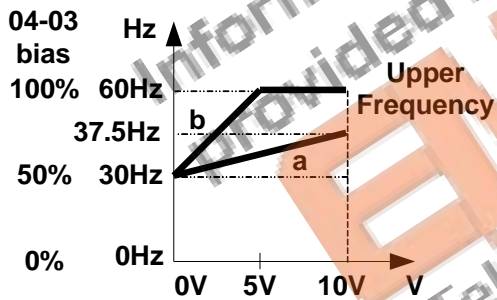

Figure8:

	04- 02	04- 03	04- 04	04- 05
c	50%	50%	0	1
d	200%	50%	0	1

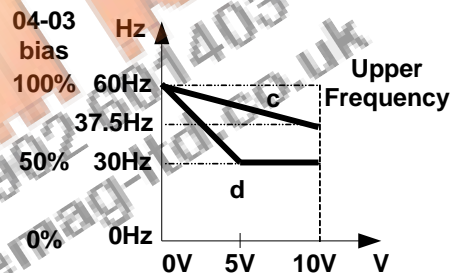

Figure9:

	04- 02	04- 03	04- 04	04- 05
e	50%	20%	1	0
f	200%	20%	1	0

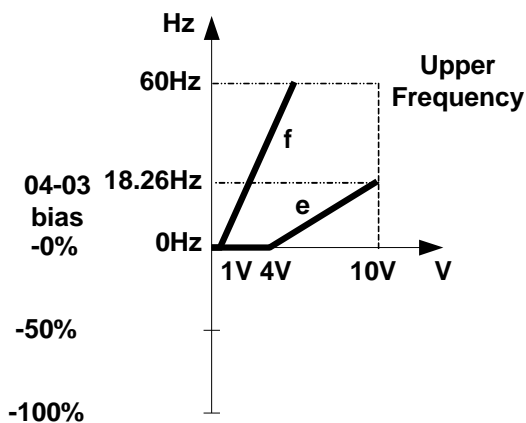
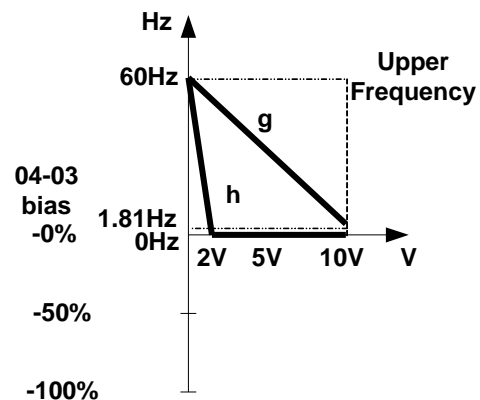

Figure10:

	04- 02	04- 03	04- 04	04- 05
g	50%	50%	1	1
h	200%	0%	0	1



<b>04-11</b>	<b>Analog Output (AO) Function Selection.</b>
<b>Range</b>	<b>【0】</b> :Output Frequency <b>【1】</b> :Frequency Command <b>【2】</b> :Output Voltage <b>【3】</b> :DC Bus Voltage <b>【4】</b> :Output Current

Example: Set 04-11 required according to the table below.

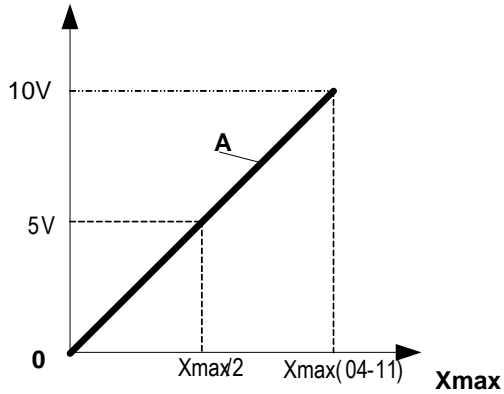

04-11	A	Xmax
<b>【0】</b>	Output frequency	upper frequency limit
<b>【1】</b>	Frequency Setting	upper frequency limit
<b>【2】</b>	Output voltage	Motor Rated Voltage
<b>【3】</b>	DC Bus Voltage	220V: 0~400V 440V: 0~800V
<b>【4】</b>	Output current	rated current of inverter

<b>04-12</b>	<b>AO Gain</b>
<b>Range</b>	<b>【0 ~ 1000】 %</b>
<b>04-13</b>	<b>AO Bias</b>
<b>Range</b>	<b>【0 ~ 100】 %</b>
<b>04-14</b>	<b>AO Bias Selection</b>
<b>Range</b>	<b>【0】 : positive      【1】 : Negative</b>
<b>04-15</b>	<b>AO Slope</b>
<b>Range</b>	<b>【0】 : positive      【1】 : Negative</b>
<b>04-16</b>	<b>F-Gain</b>
<b>Range</b>	<b>【0】 : Invalid      【1】 : Effective</b>

- Select the Analog output type for the multifunction analog output on terminal (TM2) as required by parameter 04-11. Output format is 0-10V dc.  
The output voltage level can be scaled and modified by parameters 04-12 to 04-15 If necessary.
- The modification format will be same as the examples shown previously for Analog Voltage Input (AI1) parameters 4-02 to 4-05.  
Note: the max output voltage is 10V due to the hardware of the circuit.  
Use external devices that require a maximum of 10V dc signal.

➤ F-Gain Functions:

F- Gain function provides the facility for setting the frequency reference to more than one inverter set by a master potentiometer then the master frequency can be scaled by three individual potentiometers for each inverter as show in the diagram below.

To use this function set Parameter 04-16=1 and set parameter 00-05 =2 (external Analog input AI1) and AI2 will be the scaling potentiometer.

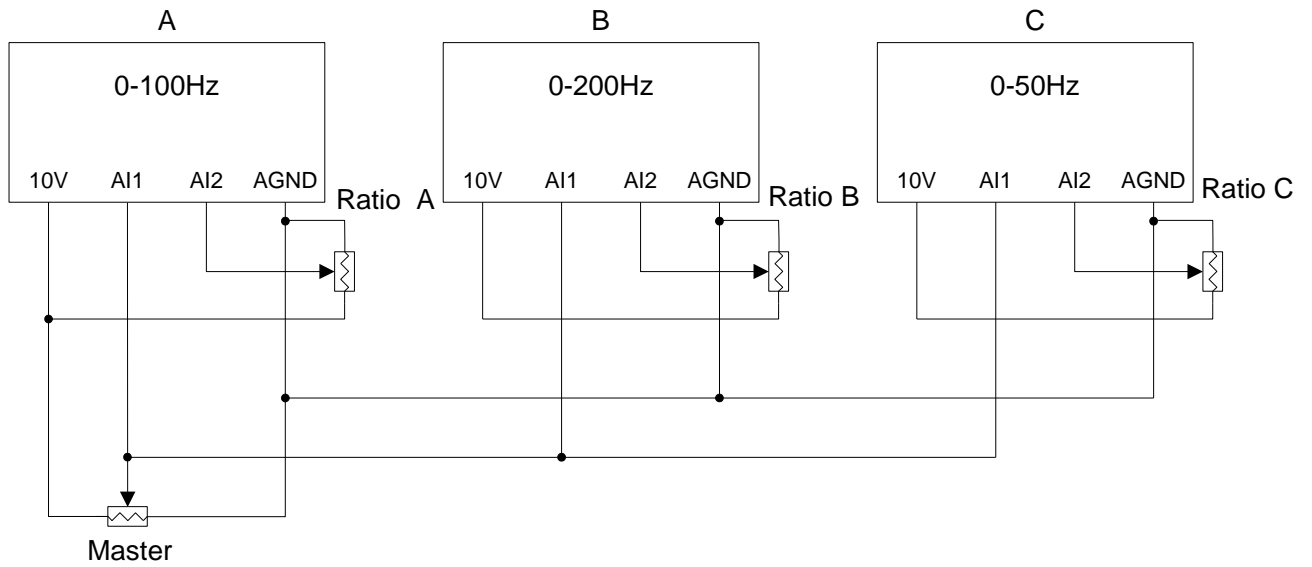

Parameter Preset:

A	B	C
00-05=2	00-05=2	00-05=2
00-12=100	00-12=200	00-12=50
04-16=1	04-16=1	04-16=1

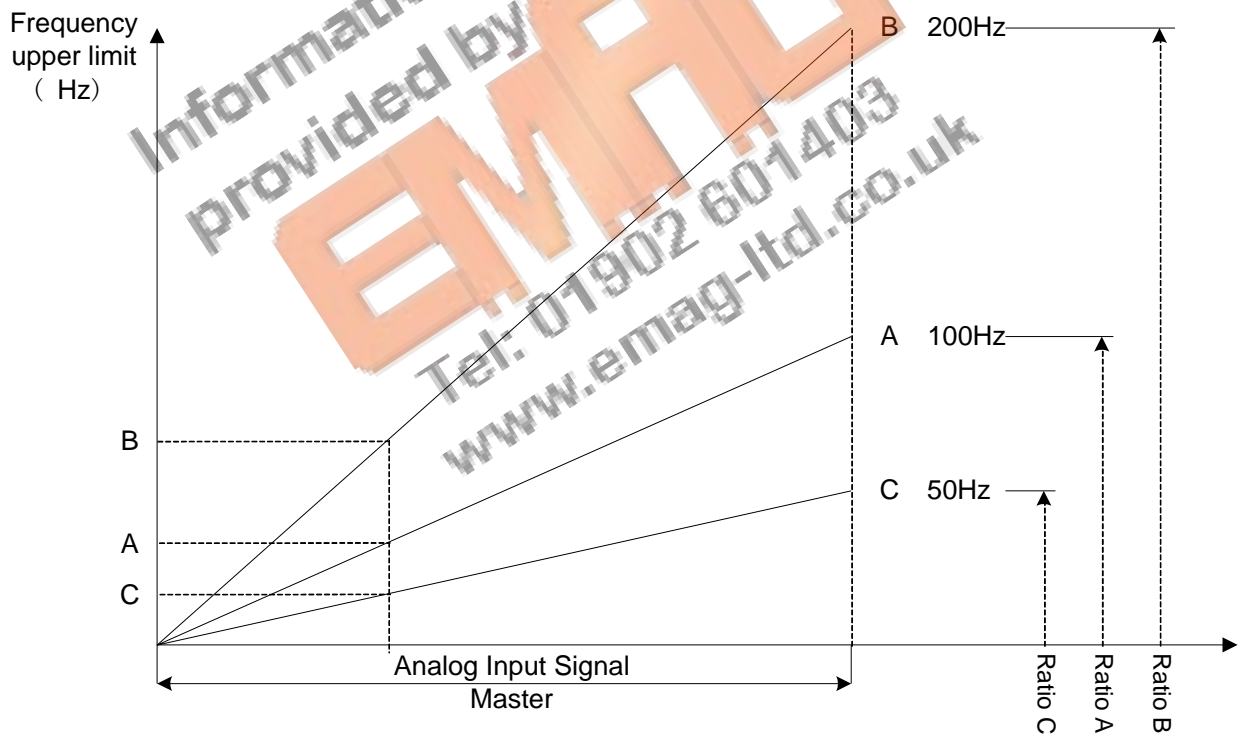

## 05- Preset Frequency Selections

05- 00	Presets Speed Control mode Selection
Range	<b>【0】</b> : Common Accel/Decel <b>【1】</b> : Individual Accel/Decel for each preset speed 0-15

05- 01	Presets Speed 0 (Keypad Freq)
05- 02	Presets Speed 1
05- 03	Presets Speed 2
05- 04	Presets Speed 3
05- 05	Presets Speed 4
05- 06	Presets Speed 5
05- 07	Presets Speed 6
05- 08	Presets Speed 7
05- 09	Presets Speed 8
05- 10	Presets Speed 9
05- 11	Presets Speed 10
05- 12	Presets Speed 11
05- 13	Presets Speed 12
05- 14	Presets Speed 13
05- 15	Presets Speed 14
05- 16	Presets Speed 15
Range	<b>【0.00 ~ 650.00】</b> Hz
05-17	Presets Speed 0 Acceleration time
05-18	Presets Speed 0 Deceleration time
05-19	Presets Speed 1 Acceleration time
05- 20	Presets Speed 1 Deceleration time
05- 21	Presets Speed 2 Acceleration time
05- 22	Presets Speed 2 Deceleration time
05- 23	Presets Speed 3 Acceleration time
05- 24	Presets Speed 3 Deceleration time
05- 25	Presets Speed 4 Acceleration time
05- 26	Presets Speed 4 Deceleration time
05- 27	Presets Speed 5 Acceleration time
05- 28	Presets Speed 5 Deceleration time
05- 29	Presets Speed 6 Acceleration time
05- 30	Presets Speed 6 Deceleration time
05- 31	Presets Speed 7 Acceleration time
05- 32	Presets Speed 7 Deceleration time
05- 33	Presets Speed 8 Acceleration time
05- 34	Presets Speed 8 Deceleration time
05- 35	Presets Speed 9 Acceleration time
05- 36	Presets Speed 9 Deceleration time
05- 37	Presets Speed 10 Acceleration time
05- 38	Presets Speed 10 Deceleration time
05- 39	Presets Speed 11 Acceleration time
05- 40	Presets Speed 11 Deceleration time
05- 41	Presets Speed 12 Acceleration time
05- 42	Presets Speed 12 Deceleration time
05- 43	Presets Speed 13 Acceleration time
05- 44	Presets Speed 13 Deceleration time
05- 45	Presets Speed 14 Acceleration time
05- 46	Presets Speed 14 Deceleration time
05- 47	Presets Speed 15 Acceleration time
05- 48	Presets Speed 15 Deceleration time
Range	<b>【0.1 ~ 3600.0】</b> Sec

- When 05- 00 = 【0】 , Accel /Decel 1 or 2 set by parameters 00-14/00-15 or 00-16/00-17 apply to all speeds.
- When 05- 00 = 【1】 , When 05- 00 = 【1】 Individual Accel/Decel apply to each preset speed 0-15. Parameters 05-17 to 05-48.
- Formula for calculating acceleration and deceleration time:

$$\text{Actual Acc time} = \frac{\text{Time of Accel1 or 2 x Preset Frequency}}{\text{Max Frequency}}$$

$$\text{Actual Dec time} = \frac{\text{Time of Accel1 or 2 x Preset Frequency}}{\text{Max Frequency}}$$

- Maximum output frequency = parameter 01-02 when programmable V/F is selected by 01- 00= 【18】
- Maximum output frequency = 50.00 hz or 60.00 hz when preset V/F patterns are selected by 01- 00≠ 【18】

Example : 01- 00≠ 【18】 ,01- 02= 【50】 hz, 05- 02= 【10】 hz(preset speed1),  
05-19= 【5】 s(Acc-time),05-20= 【20】 s(Dec-time)

$$\text{Preset speed 1 Actual Acc time} = \frac{(05-19) \times 10(\text{Hz})}{01-02} = 1(\text{s})$$

$$\text{Preset speed 1 Actual Dec time} = \frac{(05-20) \times 10(\text{Hz})}{01-02} = 4(\text{s})$$

- **Multi speed run/stop cycles with Individual accel/decel times. 05-00= 【1】**

- Two modes are shown below:-
- Mode1 = On/Off run command
- Mode2= Continuous run command

**Mode1 Example:**

00- 02= 【1】 (External Run/Stop Control).

00- 04= 【1】 (Operation Mode: Run/stop-forward/reverse).

S1: 03- 00= 【0】 (RUN/STOP )

S2: 03- 01= 【0】 (Forward/Reserve)

S3: 03- 02= 【2】 (Preset speed 1)

S4: 03- 03= 【3】 (Preset speed 2);

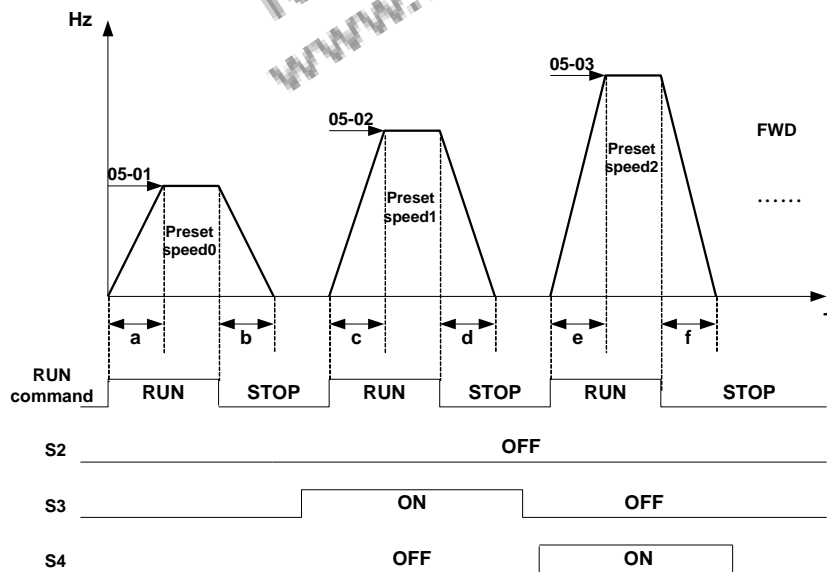

When the run command is On/Off, acceleration and deceleration times for each cycle can be calculated as below:- time unit is in seconds.



$$a = \frac{(05-17) \times (05-01)}{01-02}, b = \frac{(05-18) \times (05-01)}{01-02}, c = \frac{(05-19) \times (05-02)}{01-02}, d = \frac{(05-20) \times (05-02)}{01-02} \dots$$

Unit (sec)

- **Mode2 Example.** Continuous run command.
- Set S1 for Continuous Run
- Set S2 For Forward /Reverse direction selection
- Set multi function terminals S3,S4 & S5 for setting three different preset speeds

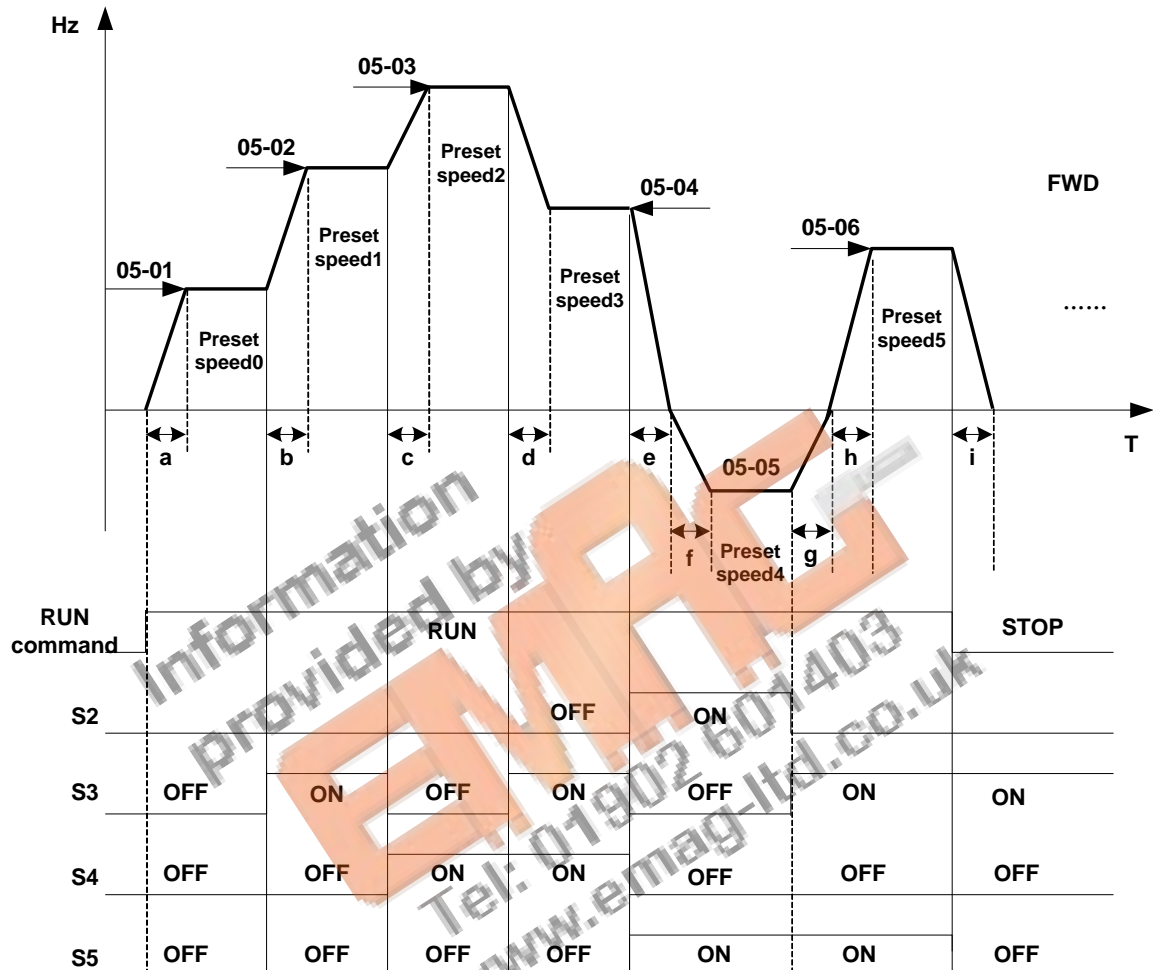

When the run command is continuous, acceleration and deceleration times for each segment can be calculated as below:-

$$a = \frac{(05-17) \times (05-01)}{01-02}, b = \frac{(05-19) \times [(05-02) - (05-01)]}{01-02}, c = \frac{(05-21) \times [(05-03) - (05-02)]}{01-02}$$

$$d = \frac{(05-24) \times [(05-03) - (05-04)]}{01-02}, e = \frac{(05-26) \times (05-05)}{01-02}, f = \frac{(05-25) \times (05-05)}{01-02},$$

$$g = \frac{(05-28) \times (05-05)}{01-02}, h = \frac{(05-27) \times (05-06)}{01-02}, i = \frac{(05-28) \times (05-06)}{01-02} \dots \text{Unit (sec)}$$

## 06- Auto Run(Auto Sequencer) Function

06- 00	Auto Run( sequencer) mode selection
Range	<p><b>【0】</b> :Disabled</p> <p><b>【1】</b> :Single cycle (Continues to run from the unfinished step if restarted).</p> <p><b>【2】</b> :Periodic cycle. (Continues to run from the unfinished step if restarted).</p> <p><b>【3】</b> :Single cycle, then holds the speed of final step to run. (Continues to run from the unfinished step if restarted).</p> <p><b>【4】</b> :Single cycle. (Starts a new cycle if restarted).</p> <p><b>【5】</b> :Periodic cycle. (Starts a new cycle if restarted).</p> <p><b>【6】</b> :Single cycle, then hold the speed of final step to run. (Starts a new cycle if restarted).</p>

Frequency of the step 0 is set by parameter 05-01 keypad Frequency.	
06- 01	Auto _ Run Mode Frequency Command 1
06- 02	Auto _ Run Mode Frequency Command 2
06- 03	Auto _ Run Mode Frequency Command 3
06- 04	Auto _ Run Mode Frequency Command 4
06- 05	Auto _ Run Mode Frequency Command 5
06- 06	Auto _ Run Mode Frequency Command 6
06- 07	Auto _ Run Mode Frequency Command 7
06- 08	Auto _ Run Mode Frequency Command 8
06- 09	Auto _ Run Mode Frequency Command 9
06- 10	Auto _ Run Mode Frequency Command 10
06- 11	Auto _ Run Mode Frequency Command 11
06- 12	Auto _ Run Mode Frequency Command 12
06- 13	Auto _ Run Mode Frequency Command 13
06- 14	Auto _ Run Mode Frequency Command 14
06- 15	Auto _ Run Mode Frequency Command 15
Range	<b>【0.00 ~ 650.00】</b> Hz

06- 16	Auto _ Run Mode Running Time Setting0
06- 17	Auto _ Run Mode Running Time Setting1
06- 18	Auto _ Run Mode Running Time Setting2
06- 19	Auto _ Run Mode Running Time Setting3
06- 20	Auto _ Run Mode Running Time Setting4
06- 21	Auto _ Run Mode Running Time Setting5
06- 22	Auto _ Run Mode Running Time Setting6
06- 23	Auto _ Run Mode Running Time Setting7
06-24	Auto _ Run Mode Running Time Setting8
06-25	Auto _ Run Mode Running Time Setting9
06-26	Auto _ Run Mode Running Time Setting10
06-27	Auto _ Run Mode Running Time Setting11
06-28	Auto _ Run Mode Running Time Setting12
06-29	Auto _ Run Mode Running Time Setting13
06-30	Auto _ Run Mode Running Time Setting14
06-31	Auto _ Run Mode Running Time Setting15
Range	<b>【0.00 ~ 3600.0】</b> Sec

06- 32	Auto _ Run Mode Running Direction 0
06- 33	Auto _ Run Mode Running Direction1
06- 34	Auto _ Run Mode Running Direction2
06- 35	Auto _ Run Mode Running Direction3
06- 36	Auto _ Run Mode Running Direction4
06- 37	Auto _ Run Mode Running Direction5

06- 38	Auto_ Run Mode Running Direction6
06- 39	Auto_ Run Mode Running Direction7
06- 40	Auto_ Run Mode Running Direction8
06- 41	Auto_ Run Mode Running Direction9
06- 42	Auto_ Run Mode Running Direction10
06- 43	Auto_ Run Mode Running Direction11
06- 44	Auto_ Run Mode Running Direction12
06- 45	Auto_ Run Mode Running Direction13
06- 46	Auto_ Run Mode Running Direction14
06- 47	Auto_ Run Mode Running Direction15
Range	<b>【0】 : STOP      【1】 : Forward      【2】 : Reverse</b>

- Auto Run (sequencer) mode has to be enabled by using one of the multifunctional inputs S1 to S6 and setting the relevant parameter 03-00 to 03-04 to selection **【18】** .
- Various Auto Run (sequencer) modes can be selected by parameter (06-00) as listed above.
- 15 Auto Run (sequencer) modes can be selected by parameters (06-01~06-39)
- Auto Run frequency commands1 to 15 are set with Parameters (06-01 ~ 06-07),
- Sequence run times are set with parameters (06-17 ~ 06-23)
- FWD/REV Direction for each sequence can be set with parameters (06-33 ~ 06-39).
- Auto sequence 0, frequency is set from keypad by parameter 05-01, sequence run time and direction are set by parameters 06-16 and 06-32.

**Auto RUN ( Auto Sequencer) examples are shown in the following pages:-**

**Example 1.** Single Cycle (06- 00=1,4)

The inverter will run for a single full cycle based on the specified number of sequences, then it will stop. In this example 4 sequences are set, three in forward direction and one in Reverse.

.Auto Run Mode      06- 00= **【1】** (or **【4】** ),  
Frequency            05-01= **【15】** Hz, 06- 01= **【30】** Hz, 06- 02= **【50】** Hz, 06- 03= **【20】** Hz  
Sequence Run Time 06-16= **【20】** s, 06-17= **【25】** s, 06-18= **【30】** s 06-19= **【40】** s,  
Direction            06-32= **【1】** ,    06-33= **【1】** ,    06-34= **【1】** (FWD), 06-35= **【2】** (REV),  
Unused Sequence Parameters    06-04~ 06-15= **【0】** Hz ,    06-20~06-31=**【0】**s , 06-36~06-47=**【0】**

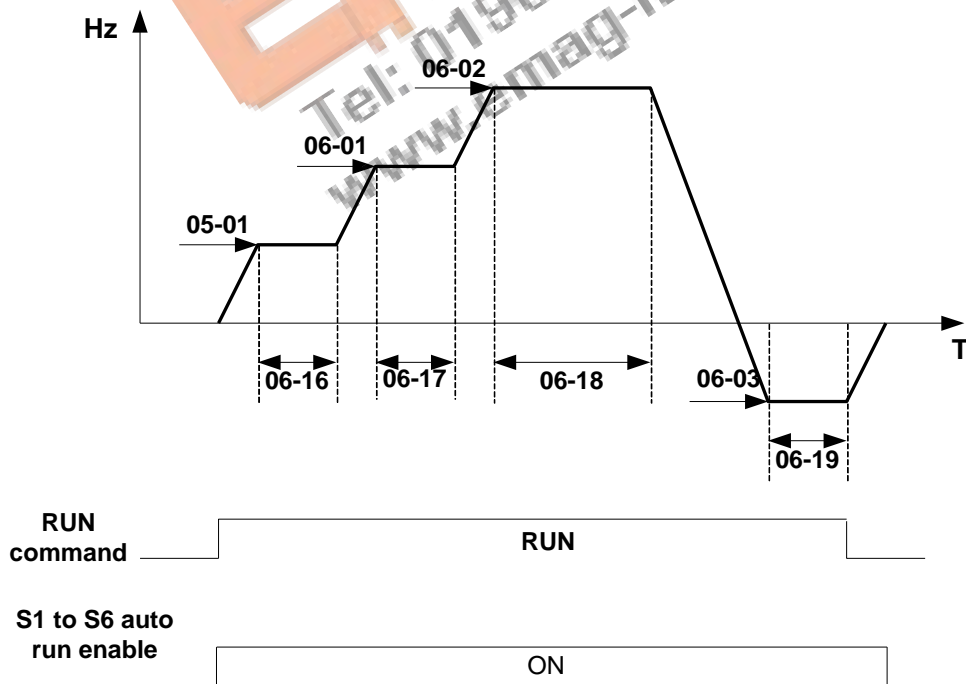

**Example 2: Periodic Cycle Run.**

Mode: 06- 00= **[ 2 ]** or **[ 5 ]**

The inverter will repeat the same cycle periodically.

All other Parameters are set same as Example 1. shown above

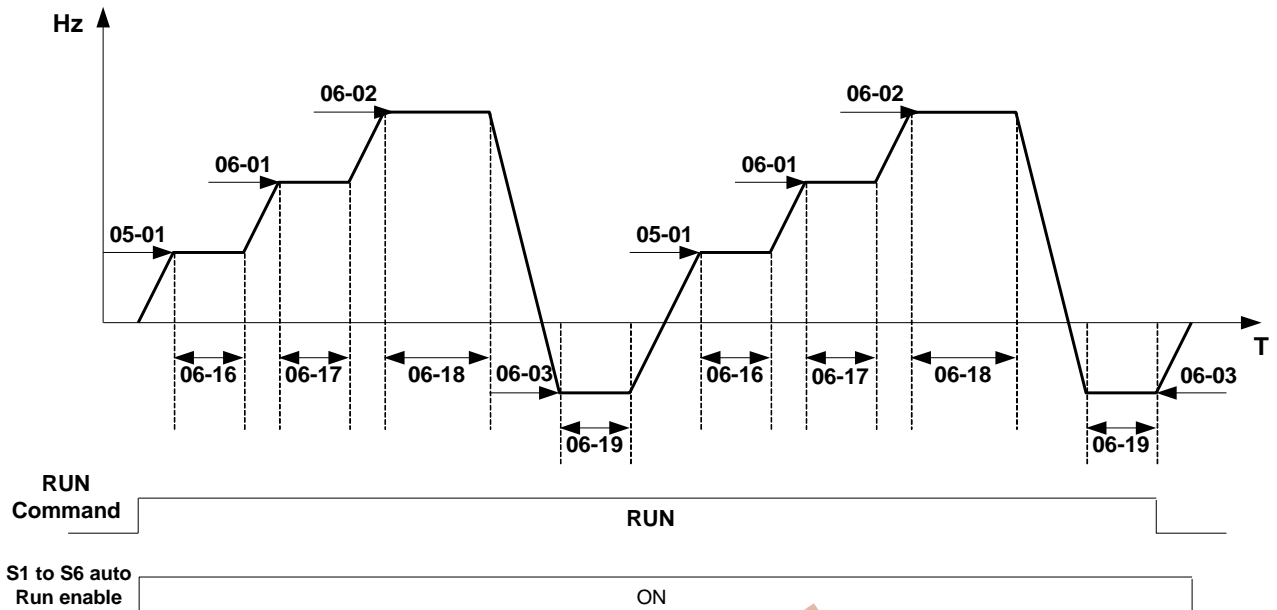

**Example 3. Auto\_Run Mode for Single Cycle 06-00= **[ 3 or 6 ]****

The speed of final step will be held to run.

Auto Run Mode 06- 00 = **[ 3 ]** (or **[ 6 ]**),

Frequency 05- 01= **[ 15 ]** Hz, 06- 01= **[ 30 ]** Hz, 06- 02= **[ 50 ]** Hz, 06- 15= **[ 20 ]** Hz,

Sequence Run Time 06-16= **[ 20 ]** s, 06-17= **[ 25 ]** s, 06-18= **[ 30 ]** s, 06-31= **[ 40 ]** s,

Direction 06-32= **[ 1 ]**, 06-33= **[ 1 ]**, 06-34= **[ 1 ]**, 06-47= **[ 1 ]** (FWD),

Unused Sequence Parameters 06-04~06- 15= **[ 0 ]** Hz , 06-19~06-30= **[ 0 ]** s , 06-35~06-46 = **[ 0 ]**

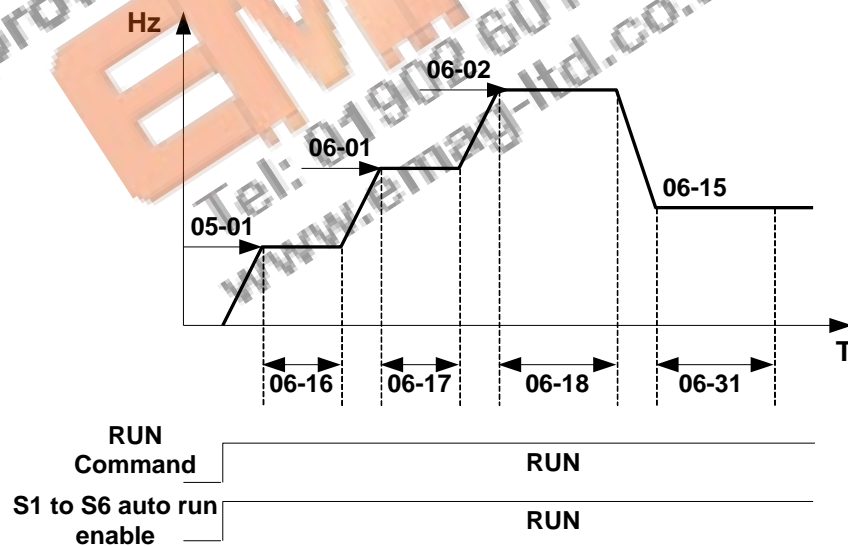

**Example 4&5 .**

**Auto\_Run Mode 06-00= **[ 1~3 ]**** . After a restart, it continues to run from the unfinished step.

**Auto\_Run Mode 6- 00= **[ 4~6 ]**** . After a restart, it will begin a new cycle.

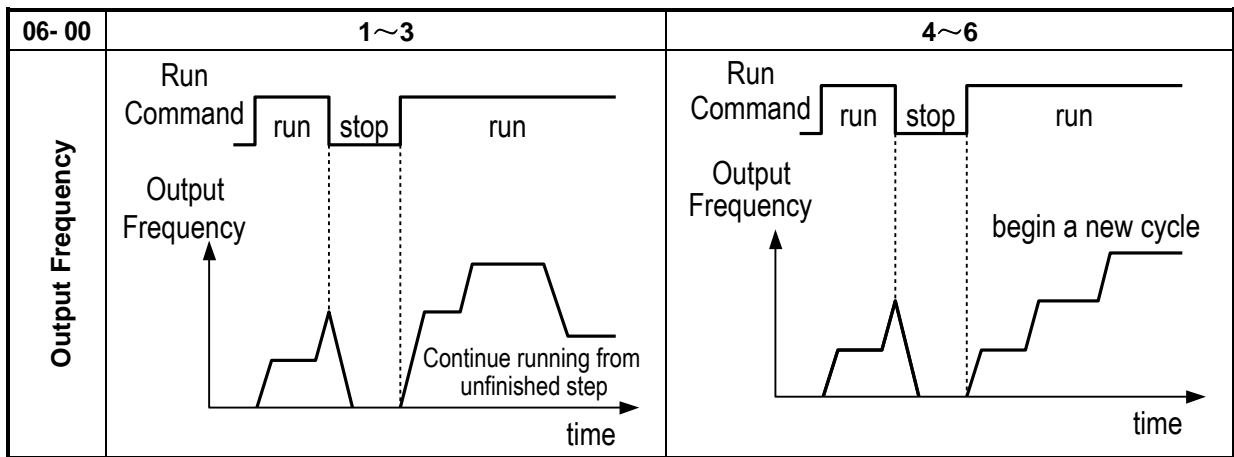

- ACC/DEC time in Auto run mode will be according to the setting of 00-14/00-15 or 00-16/00-17.
- For Auto sequence 0. The run frequency will be according to keypad frequency set by parameter 05-01. Parameters 06-16 and 06-32 are used to set the sequence Run time and Run direction.

### 07- Start/Stop Command Setup

07-00	<b>Momentary power loss and restart</b>
Range	<b>【0】 :Momentary Power Loss and Restart Disable</b> <b>【1】 :Momentary Power Loss and Restart Enable</b>

- If the input power supply due to sudden increase in supply demand by other equipment results in voltage drops below the under voltage level, the inverter will stop its output at once.
- When 07-00 = **【0】** .On power loss, the inverter will not start.
- When 07-00 = **【1】** .After a momentary power loss, inverter will restart with half frequency before power loss, and there is no limitation on number of restarts.
- On power loss, as long as the inverter CPU power is not completely lost, the momentary power loss restart will be effective, restart will be according to setting of parameters 00-02 & 07-04 and status of External run switch.

**Caution:-** After any power loss if the Run mode is set to External by parameter 00-02=1 and if Direct start on power up is also selected by parameter 07-04=0, please note that the inverter will run on resumption of power.

To ensure safety of operators and to avoid any damages to the machinery, all necessary safety measure must be considered, including disconnection of power to the inverter.

07-01	<b>Auto Restart Delay Time</b>
Range	<b>【0.0~800.0】 s</b>
07-02	<b>Number of Auto Restart Attempts</b>
Range	<b>【0~10】</b>

- 07-02= **【0】** : The inverter will not auto restart after trips due to fault.
- 07-02> **【0】** , 07-01= **【0】** .After a trip due to fault the inverter will run with half frequency before power loss, and restarts after an internal delay of 0.5 seconds.
- 07-02> **【0】** , 07-01> **【0】** , After a fault trip the inverter will run with half frequency before power loss, and restart with a delay according the preset in parameter 07-01.

**Note: Auto restart after a fault will not function while DC injection braking or decelerating to stop**

<b>07- 03</b>	<b>Reset Mode Setting</b>
<b>Range</b>	<b>【0】 :Enable Reset Only when Run Command is Off</b> <b>【1】 :Enable Reset when Run Command is On or Off</b>

- 07-03=0 Once the inverter is detected a fault, please turn Run switch Off and then On again to perform reset, otherwise restarting will not be possible.

<b>07- 04</b>	<b>Direct Running on Power Up</b>
<b>Range</b>	<b>【0】 :Enable Direct Running on Power Up</b> <b>【1】 :Disable Direct Running on Power Up</b>
<b>07- 05</b>	<b>Delay-ON Timer (Seconds)</b>
<b>Range</b>	<b>【1.0~300.0】 Sec</b>

- When direct run on power up is selected by 07-04=0 and the inverter is set to external run by (00-02/00-03=1), if the run switch is ON as power is applied, the inverter will auto start. It is recommend that the power is turned off and the run switch is also off to avoid possibility of injury to operators and damage to machines as the power is reapplied.

**Note: IF this mode is required all safety measures must be considered including warning labels.**

- When direct run on power up is disabled by 07-04=1 and if the inverter is set to external run by (00-02/00-03=1), if the run switch is ON as power is applied, the inverter will not auto start and the display will flash with STP1. It will be necessary to turn OFF the run switch and then turn ON again to start normally.

<b>07- 06</b>	<b>DC Injection Brake Start Frequency (Hz)</b>
<b>Range</b>	<b>【0.10 ~ 10.00】 Hz</b>
<b>07- 07</b>	<b>DC Injection Brake Level (%) (Current Mode)</b>
<b>Range</b>	<b>【0.0~ 150.0】 %</b>
<b>07- 08</b>	<b>DC Injection Brake Time(Seconds)</b>
<b>Range</b>	<b>【0.0 ~ 25.5】 Sec</b>

- 07- 08 / 07- 06 set the DC injection brake duration and the brake start frequency, as shown below:

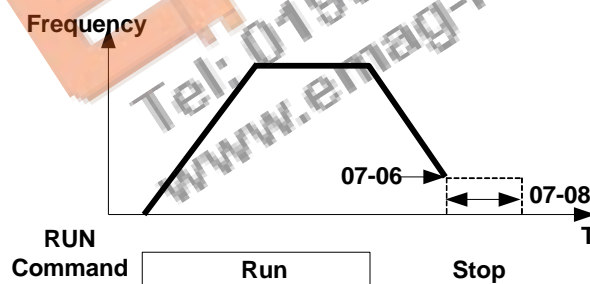

<b>07-09</b>	<b>Stopping Method</b>
<b>Range</b>	<b>【0】 : Deceleration to stop</b> <b>【1】 : Coast to stop</b>

- 07- 09 = **【0】** : After receiving stop command, the motor will decelerate to stop according to setting of 00-15, deceleration time 1.
- 07- 09 = **【1】** : After receiving stop command, the motor will free-run (Coast) to stop.

<b>07-10</b>	<b>Starting Methods</b>
<b>Range</b>	<b>【0】 : Normal Start</b> <b>【1】 : Speed Search</b>

- 07-10=0 : On starting, the inverter accelerates from 0 to target frequency in the set time.
- 07-10=1 : On starting, the inverter accelerates to target frequency from the detected speed of motor. ◦

<b>07-11</b>	<b>Starting method for auto restart after fault</b>
<b>Range</b>	<b>【0】 : Speed Search</b>



	<b>【1】 : Normal Start</b>
--	---------------------------

- 07-11=0 : When auto-restarting the inverter will detect the rotating speed of the motor. The Motor will be controlled to accelerate from the present speed to the target speed.
- 07-11=1 : The inverter restart from 0 speed to set frequency in acceleration time when auto-restart.

<b>07-12</b>	<b>Power loss ride trough time</b>
--------------	------------------------------------

<b>Range</b>	<b>【0.0 ~ 2.0】</b>
--------------	--------------------

- Power loss ride through allows continued operation after a momentary power failure as long as the power has recovered within the set time in parameter 07-12, otherwise Inverter will trip with LVC fault due to power loss.
  - On power recovery the inverter will carry out a speed search function after which the inverter output Frequency is ramped up the running frequency before the power failure.
- .Power loss recovery time setting depends on the Inverter rating; the range will be from 1 to 2 secs.
- When 07-00 = 0: Power loss ride through is disabled.
  - When 07-00 = 1: If the power loss time is less than setting in 07-12, the drive will restart with speed search after 0.5 seconds delay, and there is no limits on the number of restarts.

※ Caution

If there is a long power loss (loss time exceeds the set value of parameter 07-12) while power loss ride through function is selected by 07-00=1 and also the Run command is set to external switch 00-02=1, to avoid any danger to persons on power recovery, must ensure that the power and Run switch are in off position.

<b>07-13</b>	<b>Main Circuit Low Voltage Detection</b>
--------------	---

<b>Range</b>	<b>220V Class 【150.0~210.0】</b> <b>440V Class 【300.0~420.0】</b>
--------------	--

<b>07-14</b>	<b>Kinetic Energy Back-up Deceleration Time (KEB )</b>
--------------	--

<b>Range</b>	<b>【0.0】 : Disable</b> <b>【0.1~25.0】 : KEB Deceleration Time</b>
--------------	---

- **07-14 = 0** KEB function disable
- **07-14 ≠ 0** KEB function enable

Example: 220V system

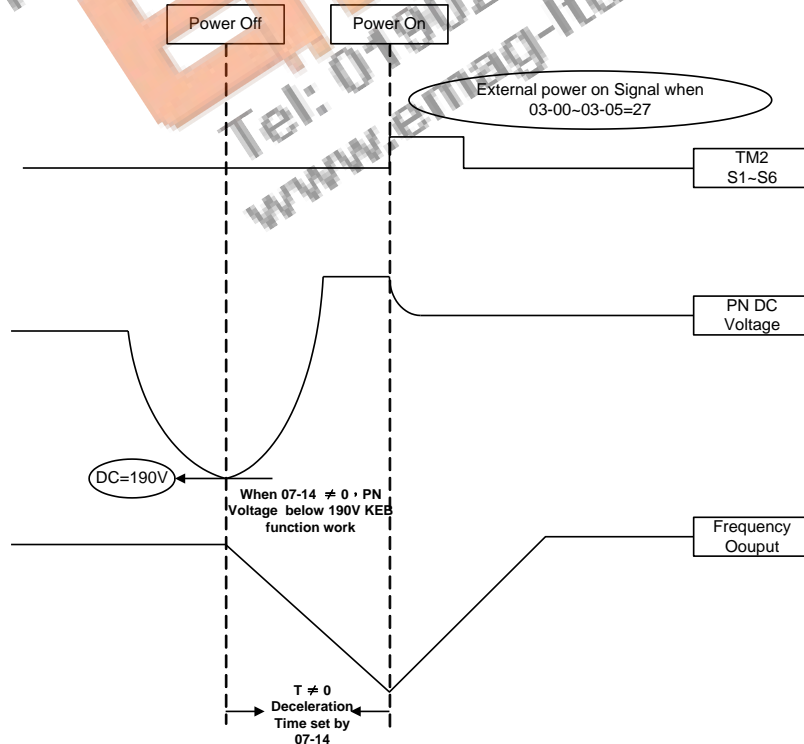

※ Note:

1. When **07-14≠0**, the momentary power loss and restart is disabled, the inverter will do KEB function.

2. When input power is turned off, CPU detects the DC bus Voltage and as soon as DC bus Voltage becomes lower than 190V (220V system) or 380V (440V system), then the KEB function is activated.
3. When KEB function is enabled, the inverter decelerate to zero by **07-14**, and the inverter stop
4. IF the power on signal enabled during the KEB function, the inverter accelerate to original frequency.

<b>07-15</b>	<b>DC injection Brake Mode</b>
<b>Range</b>	<b>【0】 Current Mode 【1】 Voltage Mode</b>
<b>07-16</b>	<b>DC Injection Brake Level (Voltage Mode)</b>
<b>Range</b>	<b>【0.0~10.0】 %</b>

**Note:** DC braking functions of voltage and current modes share two parameters of DC braking frequency (07-06) and DC braking time (07-08).

Parameters:

(1) 07-15 is used to select DC braking mode (voltage mode or current mode)

When 07-15=0, DC Injection Brake Level is determined by 07-07;

When 07-15=1, DC Injection Brake Level is determined by 07-16.

**Note:** 07-07 references on rated current. 07-16 references on 20% of V/f max output voltage.

(2) 07-16 is used to set the DC braking level in the voltage mode.

## 08- Protection function group

<b>08- 00</b>	<b>Trip Prevention Selection</b>
<b>Range</b>	<b>【xxxx0】 :Enable Trip Prevention During Acceleration</b> <b>【xxxx1】 :Disable Trip Prevention During Acceleration</b> <b>【xxx0x】 :Enable Trip Prevention During Deceleration</b> <b>【xxx1x】 :Disable Trip Prevention During Deceleration</b> <b>【xx0xx】 :Enable Trip Prevention in Run Mode</b> <b>【xx1xx】 :Disable Trip Prevention in Run Mode</b> <b>【x0xxx】 :Enable over voltage Prevention in Run Mode</b> <b>【x1xxx】 :Disable over voltage Prevention in Run Mode</b>

<b>08- 01</b>	<b>Trip Prevention Level During Acceleration</b>
<b>Range</b>	<b>【50 ~ 200】 %</b>

- Trip prevention adjustment level during acceleration to prevent over current (OC-A) trips.
- If trip prevention during acceleration is enabled and an over current occurs due to the load, then the acceleration is interrupted until the over current level is dropped below the setting in 08-01 then the acceleration is resumed.

<b>08- 02</b>	<b>Trip Prevention Level During Deceleration</b>
<b>Range</b>	<b>【50 ~ 200】 %</b>

- Trip prevention adjustment level during deceleration to prevent over Voltage (OV-C) trips.
- If trip prevention during deceleration is enabled and an over voltage occurs during stopping due to the load, then the deceleration is interrupted until the over voltage level is dropped below the setting in 08-02 then the deceleration is resumed.

<b>08- 03</b>	<b>Trip Prevention Level During Continuous Run Mode</b>
<b>Range</b>	<b>【50 ~ 200】 %</b>

- Trip prevention adjustment level during continuous Run to prevent over current (OC-C) trips.
- If trip prevention during continuous Run is enabled and an over current occurs due the load such as a sudden transient load, then the output frequency is reduced by decelerating to a lower speed until the over current level is dropped below the preset in 08-03, then the output frequency accelerates back to the normal running frequency.

<b>08- 04</b>	<b>Over Voltage Prevention Level During Run Mode</b>
<b>Range</b>	<b>【350.0VDC~390.0VDC】 (200V class) 【700.0VDC~780.0VDC】 (400V class)</b>

- Over voltage prevention level can be set by parameter 08-04 when necessary.
- When the DC bus voltage is higher than the level set in 08-04, the over voltage fault will occur

<b>08- 05</b>	<b>Electronic Motor Overload Protection Operation Mode (OL1)</b>
<b>Range</b>	<b>【0】 : Disable</b>

	<b>【1】 : Enable</b>
--	---------------------

<b>08- 06</b>	<b>Operation After Overload Protection is Activated</b>
<b>Range</b>	<b>【0】 :Coast-to-Stop After Overload Protection is Activated</b> <b>【1】 :Drive Will Not Trip when Overload Protection is Activated (OL1)</b>

- 08- 06 = **【0】** : On overload condition the inverter coast to stop as the thermal relay detects the overload and the display will flash OL1.To reset Press the 'Reset' key or use an external reset to continue to run.
- 08- 06 = **【1】** : On overload condition the inverter continues to run, display flash with OL1, until the current falls below the overload level.

<b>08- 07</b>	<b>OH Over Heat Protection</b>
<b>Range</b>	<b>【0】 :Auto (Depends on heat sink temp.)</b> <b>【1】 :Operate while in RUN mode</b> <b>【2】 :Always Run</b> <b>【3】 :Disabled</b>

- **08- 07= 【0】** : Cooling fan runs as the inverter detects temperature rise.
- **08- 07= 【1】** : Cooling fan runs while the inverter is running.
- **08- 07= 【2】** : Cooling fan runs continuously.
- **08- 07= 【3】** : Cooling fan is Disabled.

<b>08- 08</b>	<b>AVR function</b>
<b>Range</b>	<b>【0】 :AVR function enable</b> <b>【1】 :AVR function disable</b> <b>【2】 :AVR function disable for stop</b> <b>【3】 :AVR function disable for Deceleration</b> <b>【4】 :AVR function disabled for stop and Deceleration</b> <b>【5】 :when VDC&gt;360/740V , AVR function is disabled for stop and Deceleration</b>

- Automatic voltage regulator function provides a level of output voltage stability when there is input voltage instability. So when
- 08-08=0, Input voltage fluctuations will not effect the output voltage.
- 08-08=1. Input voltage fluctuations will cause fluctuations on output voltage.
- 08-08=2. AVR is disabled during stopping to avoid an increase in stopping time.
- 08-08=3. AVR is disabled **only** during deceleration from one speed to another speed. This will avoid longer than required deceleration time.
- 08-08=4 AVR function disabled for stop and deceleration.
- 08-08=5 When VDC>360V(200V class)or VDC>740V(400V class), AVR function is disabled for stop and deceleration.

<b>08- 09</b>	<b>Input Phase Loss Protection</b>
<b>Range</b>	<b>【0】 :Disabled</b> <b>【1】 :Enabled</b>

- When 08-09= **【1】** :On phase loss warring message PF is displayed..

<b>08- 10</b>	<b>Output phase lost protection</b>
<b>Range</b>	<b>【0】 :Disabled</b> <b>【1】 :Enabled</b>

- When 08-10= **【1】** : On output phase loss ,warning message LF is displayed...

<b>08- 11</b>	<b>Motor type selection:</b>
<b>Range</b>	<b>【0】 :Electronic relays protect standard motor</b> <b>【1】 : Electronic relays protect inverter duty motor</b>
<b>08- 12</b>	<b>Motor Overload Protection Curve Selection:</b>
<b>Range</b>	<b>【0】 :Constant Torque (OL =103 %) (150 % for 1 Minute)</b> <b>【1】 :Variable Torque (OL = 113 %)(123 % for 1 Minute)</b>

- When 08-11= **【0】** :Set 02-06 as the rated frequency of the motor.
- Motor overload protection level is according to the setting of 08-11 and 08-12, as follows:

OL1 level frequency (base on rated F)	08-11=0	08-11=0	08-11=1	08-11=1
	08-12=0	08-12=1	08-12=0	08-12=1
F<=33.3%	63%	63%	103%	113%
33.3%<F<90%	85%	88%		
F>=90%	103%	113%		

- When 08-12=**【0】**: Overload protection for motors used in general purpose applications, as long as the load demand is less than 103% of the rated current, the motor continues to run. If the load is larger than 150% rated current, the motor will run for 1 minute only. (curve1).
- When 08-12=**【1】**: Overload protection for motors used in HVAC applications(FAN, PUMP...so on).as long as the load demand is less than 113% of the rated current, the motor continues to run. If the load is larger than 123% rated current, the motor will run for 1 minute only (curve2).

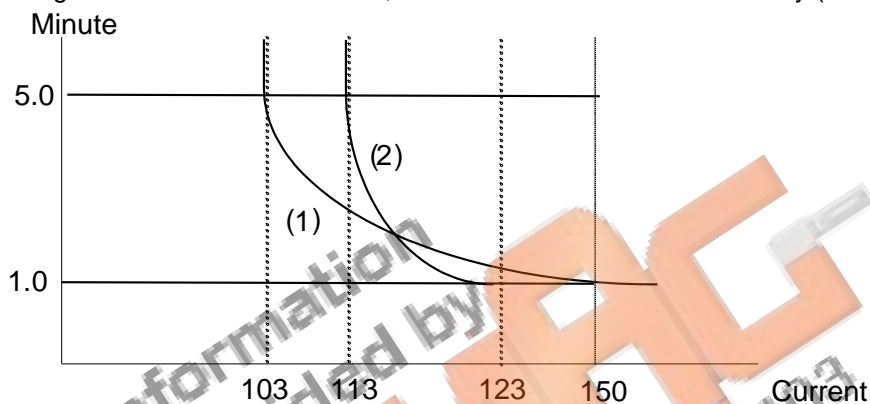

<b>08- 13</b>	<b>Over torque detection Control</b>
<b>Range</b>	<b>【0】 : Over-torque detection is not valid</b> <b>【1】 : Detected after the set frequency</b> <b>【2】 : Detect when running</b>
<b>08-14</b>	<b>Over torque protection action</b>
<b>Range</b>	<b>【0】 : Stop output after over-torque detection (Free-run stop)</b> <b>【1】 : Continue to run after over-torque detection (Display only OL3)</b>
<b>08- 15</b>	<b>Over Torque Detection Level</b>
<b>Range</b>	<b>【30 ~ 300】</b>
<b>08- 16</b>	<b>Over Torque Detection Time</b>
<b>Range</b>	<b>【0.0~25.0】</b>
<b>08- 17</b>	<b>Fire Mode</b>
<b>Range</b>	<b>【0】 : Disable</b> <b>【1】 : Enable</b>

- Over Torque is detected when the output torque level exceeds the level set in Parameter 08-15 ( Inverter rated torque is 100%) and if it is detected for a duration of time which is set in parameter 08-16.
- When 08-14= **【0】** : If there is over torque, the inverter coasts to stop and flashes OL3. It is necessary to press 'RESET' or signal reset from input terminal to continue to run.
- When 08-14= **【1】** : If there is over torque, the inverter can continue to run and flashes OL3 until the output torque is less than the 08-15 set value.
- Parameter 03-11/12(Multifunction output terminal) = 12, the output terminal signal will be set for over torque condition.
- ※ Note: Over torque detection will be enabled only when parameter 08-13 is set to options 1or 2.

**! warning:**

Selection of Fire Mode by setting parameter 08-17.

Use of this mode for any specific application must be considered carefully and all safety implications must be taken into account as all protection features of the inverter will be disabled and the unit will continue to operate until its possible destruction.

All liabilities for the use of this function will remain user's responsibility.

<b>08- 18</b>	<b>Ground Fault Detection</b>
<b>Range</b>	<b>【0】 : Disable</b> <b>【1】 : Enable</b>

ON detection of Ground fault if 08-18 = 1, fault message (GF) will be displayed..

\* **Note:** this function is only available for inverter Frames 3, 4.

### 09- Communication function setup

<b>09- 00</b>	<b>Assigned Communication Station Number</b>
<b>Range</b>	<b>【1 ~ 32】</b>

- 09-00 to sets the communication station number when there is more that one unit on the communication network. Up to 32 Slave units can be controlled from one master controller such as a PLC.

<b>09- 01</b>	<b>RTU code /ASCII code Selection</b>
<b>Range</b>	<b>【0】 :RTU</b> <b>【1】 :ASCII</b>
<b>09- 02</b>	<b>Baud Rate Setting (bps)</b>
<b>Range</b>	<b>【0】 :4800</b> <b>【1】 :9600</b> <b>【2】 :19200</b> <b>【3】 :38400</b>
<b>09- 03</b>	<b>Stop Bit Selection</b>
<b>Range</b>	<b>【0】 :1 stop bit</b> <b>【1】 :2 stop bits</b>
<b>09- 04</b>	<b>Parity Selection</b>
<b>Range</b>	<b>【0】 :No Parity</b> <b>【1】 :Even Parity</b> <b>【2】 :Odd Parity</b>
<b>09- 05</b>	<b>Data Format Selection</b>
<b>Range</b>	<b>【0】 :8 bit data</b> <b>【1】 :7 bit data</b>

- Set 09-01~09-05 to configure communication format before starting communication.

<b>09- 06</b>	<b>Communication time-out detection time</b>
<b>Range</b>	<b>【0.0~25.5】 s</b>
<b>09- 07</b>	<b>Communication time-out operation selection</b>
<b>Range</b>	<b>【0】 :Stop in deceleration time 1 and show COT after communication timeout</b> <b>【1】 :Stop in free run mode and show COT after communication timeout</b> <b>【2】 :Stop in deceleration time 2 and show COT after communication timeout</b> <b>【3】 :Keep running and show COT after communication timeout</b>

- Time-out detection time: 00.0~25.5sec; setting 00.0 sec: disable time-out function.

<b>09- 08</b>	<b>Comm. fault tolerance count.</b>
<b>Range</b>	<b>【1~20】</b>



- When number of communication errors  $\geq$  09-08 setting, keypad display shows ERR6.

<b>09-09</b>	<b>Wait time of inverter transmission</b>
<b>Range</b>	<b>【5-65】 ms</b>

Sets the inverter response delay time. This is the time between the controller message and the start of the inverter response message. Refer to figure. Set the controller receive time-out to a greater value than the wait time parameter (09-09).

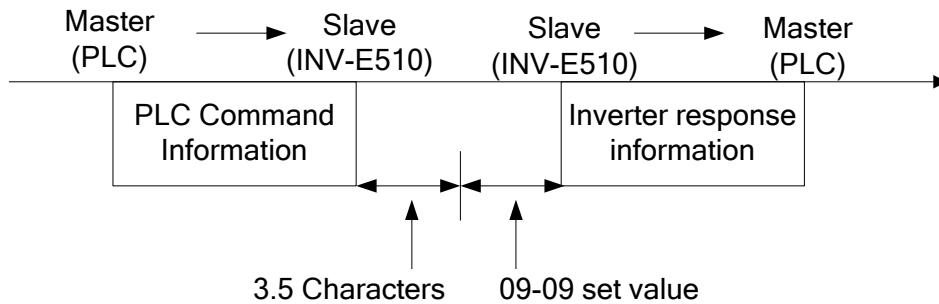

### 10-PID function Setup

#### PID block diagram

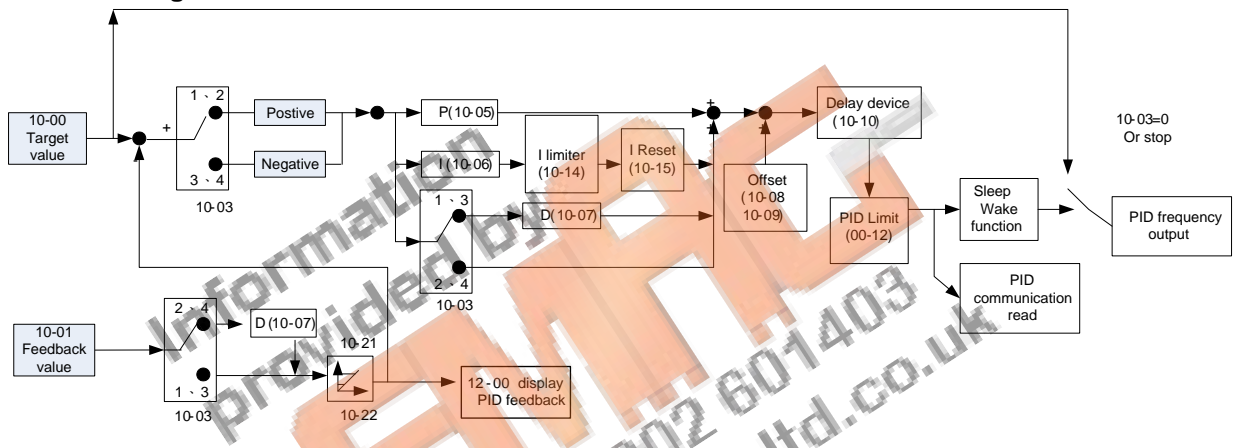

<b>10-00</b>	<b>PID target value selection</b>
<b>Range</b>	<b>【0】</b> :Potentiometer on Keypad <b>【1】</b> :External AI1 Analog Signal Input <b>【2】</b> :External AI2 Analog Signal Input <b>【3】</b> :Target Frequency set by Communication method. <b>【4】</b> :Set from keypad by parameter 10-02.

- 10-00 selections are only effective when frequency source selection is set to PID by parameters 00-05 / 00-06 = 6.

<b>10-01</b>	<b>PID feedback value selection</b>
<b>Range</b>	<b>【0】</b> :Potentiometer on Keypad <b>【1】</b> :External AI1 Analog Signal Input <b>【2】</b> :External AI2 Analog Signal Input <b>【3】</b> :Communication setting Frequency

※ **Note:** 10-00 and 10-01 can not be set to the same value.

<b>10-02</b>	<b>PID Keypad Input</b>
<b>Range</b>	<b>【0.0~100.0】 %</b>



<b>10- 03</b>	<b>PID Mode Selection</b>	
<b>Range</b>	<b>【0】 :PID Function disabled</b>	
	<b>【1】 :FWD Characteristic.</b>	<b>Deviation is D-controlled</b>
	<b>【2】 :FWD Characteristic.</b>	<b>Feedback is D-controlled</b>
	<b>【3】 :REV Characteristic.</b>	<b>Deviation is D-controlled</b>
	<b>【4】 :REV Characteristic.</b>	<b>Feedback is D-controlled</b>

➤ 10- 03 = **【1】**

Deviation (target/detected value) is derivative controlled in unit time set in parameter 10-07.

➤ 10- 03 = **【2】**

Feed back (detected value) is derivative controlled in unit time set in parameter 10- 07.

➤ 10- 03 = **【3】**

Deviation (target value –detected value) is derivative controlled in unit time set in parameter 10- 07. If the deviation is positive, the output frequency decreases, vice versa.

➤ 10- 03 = **【4】**

Feed back (detected value) is derivative controlled in unit time set in parameter 10- 07.

If the deviation is positive, the output frequency decreases, vice versa.

**Note:-**

For 10-03 = 1 or 2, If the deviation is positive, the output frequency increases and, vice versa.

For 10-03 = 3 or 4, If the deviation is positive, the output frequency decreases, vice versa.

<b>10- 04</b>	<b>Feedback Gain Coefficient</b>
<b>Range</b>	<b>【0.00 ~ 10.00】</b>

➤ 10-04 is the calibration gain. Deviation = (set point –feedback signal)×10-04

<b>10- 05</b>	<b>Proportional Gain</b>
<b>Range</b>	<b>【0.0 ~ 10.0】</b>

➤ 10- 05 : Proportion gain for P control.

<b>10- 06</b>	<b>Integral Time</b>
<b>Range</b>	<b>【0.0 ~ 100.0】 Sec</b>

➤ 10- 06: Integrate time for I control

<b>10- 07</b>	<b>Derivative Time</b>
<b>Range</b>	<b>【0.00 ~ 10.00】 Sec</b>

➤ 10- 07 : Differential time for D control

<b>10- 08</b>	<b>PID Offset</b>
<b>Range</b>	<b>【0】 : Positive Direction</b>
	<b>【1】 : Negative Direction</b>

<b>10- 09</b>	<b>PID Offset</b>
<b>Range</b>	<b>【0 ~ 109】 %</b>

➤ 10- 08 /10- 09: Calculated PID output is offset by 10-09 (the polarity of offset is according to10-08)

<b>10-10</b>	<b>PID Output Lag Filter Time</b>
<b>Range</b>	<b>【0.0 ~ 2.5】 Sec</b>

➤ 10-10: Update time for output frequency.

<b>10-11</b>	<b>Feedback Loss Detection Mode</b>
<b>Range</b>	<b>【0】 :Disable</b>
	<b>【1】 :Enable – Drive Continues to Operate After Feedback Loss</b>
	<b>【2】 :Enable – Drive “STOPS” After Feedback Loss</b>

➤ 10-11= **【0】** : Disable;

➤ 10-11= **【1】** : On feed back loss detection, continue running, and display 'PDER';

➤ 10-11= **【2】** : On feed back loss detection, stop, and display 'PDER'.

<b>10-12</b>	<b>Feedback Loss Detection Level</b>
<b>Range</b>	<b>【0 ~ 100】</b>

➤ 10-12 is the level for signal loss. Error = (Set point – Feedback value). When the error is larger than the loss level setting, the feedback signal is considered lost.

<b>10-13</b>	<b>Feedback Loss Detection Delay Time</b>
<b>Range</b>	<b>【0.0 ~25.5】 Sec</b>

- 10-13: The minimum time to consider the feedback signal loss is determined.

<b>10-14</b>	<b>Integration Limit Value</b>
<b>Range</b>	<b>【0 ~ 109】 %</b>

- 10-14: the Limiter to prevent the PID from saturating.

<b>10-15</b>	<b>Integral Value Resets to Zero when Feedback Signal Equals the Target Value</b>
<b>Range</b>	<b>【0】 : Disable 【1】 : After 1 Sec 【30】 : After 30 Sec ( Range:- 1 ~ 30Sec)</b>

- 10-15=0: As PID feedback value reaches the set point, the integrator will not be reset to 0.
- 10-15=1~30: As PID feedback value reaches the set point, reset to 0 in 1~30 seconds and inverter stops. The inverter will run again when the feedback value differs from the set point value.

<b>10-16</b>	<b>Allowable Integration Error Margin (Unit) (1 Unit = 1/8192)</b>
<b>Range</b>	<b>【0 ~ 100】 %</b>

- 10-16=0 ~ 100% unit value: Restart the tolerance after the integrator reset to 0.

<b>10-17</b>	<b>PID Sleep Frequency Level</b>
--------------	----------------------------------

<b>Range</b>	<b>【0.00~650.00】 Hz</b>
--------------	-------------------------

<b>10-18</b>	<b>PID Sleep Function Delay Time</b>
--------------	--------------------------------------

<b>Range</b>	<b>【0.0 ~25.5】 Sec</b>
--------------	------------------------

<b>10-19</b>	<b>PID Wake up Frequency Level</b>
--------------	------------------------------------

<b>Range</b>	<b>【0.00 ~ 650.00】 Hz</b>
--------------	---------------------------

<b>10-20</b>	<b>PID Wake Up Function Delay Time</b>
--------------	--

<b>Range</b>	<b>【0.0 ~ 25.5】 Sec</b>
--------------	-------------------------

- When PID output frequency is less than the sleep threshold frequency and exceeds the time of sleep delay, the inverter will decelerate to 0 and enters PID sleep mode.
- When PID output frequency is larger than the Wake up threshold frequency inverter will enter the PID mode again as shown in the timing diagram below.

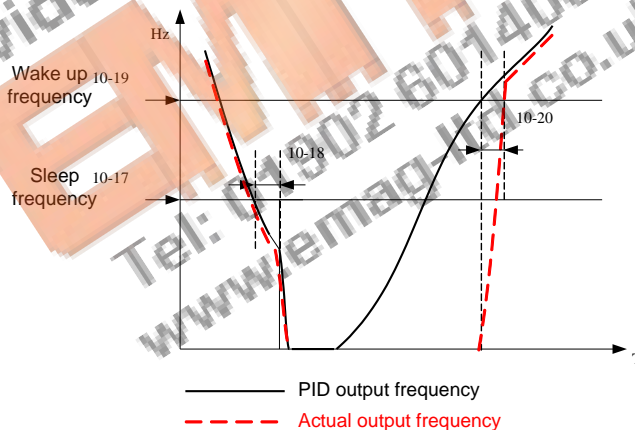

<b>10-21</b>	<b>Max PID Feedback Level.</b>
--------------	--------------------------------

<b>Range</b>	<b>【0 ~ 999】</b>
--------------	------------------

<b>10-22</b>	<b>Min PID Feedback Level.</b>
--------------	--------------------------------

<b>Range</b>	<b>【0 ~ 999】</b>
--------------	------------------

- Example: If 10-21=100 and 10-22=50 and the unit for the range from 0 to 999 will be defined with the parameters setting of 12-02, actual feedback value variation range, will be scaled to 50 and 100 only for display, as Shown below.

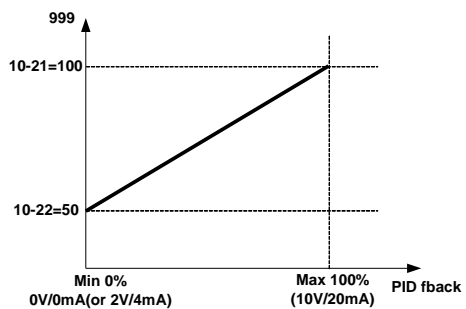

Information  
 provided by  
**EMAG**  
 Tel: 01902 601403  
[www.emag-ltd.co.uk](http://www.emag-ltd.co.uk)

## 11 Performance Control Functions

<b>11- 00</b>	<b>Prevention of Reverse operation</b>
<b>Range</b>	<b>【0】 :Reverse command is enabled</b> <b>【1】 :Reverse command is disabled</b>

- 11-00=1, the reverse command is disabled.

<b>11- 01</b>	<b>Carrier Frequency</b>
<b>Range</b>	<b>【1~16】 kHz</b>

- While IGBT-driven inverter can provide low-noise working environment, the high frequency devices have carrier frequency waveform cutting, it may interfere with external electronic device, even caused vibration when connected with motor, and then need to adjust the carrier frequency.

<b>11- 02</b>	<b>Carrier mode selection</b>
<b>Range</b>	<b>【0】 :Carrier mode0 3-phase PW M modulation</b> <b>【1】 :Carrier mode1 2-phase PW M modulation</b> <b>【2】 :Carrier mode2 2-phase randomized PW M modulation</b>

- Mode 0: 3-phase PWM Modulation Three Output transistors on at the same time (Full Duty).
- Mode 1: 2-phase PWM Modulation Two output transistors on at the same time (2/3 Duty).
- Mode 2: Random PWM Modulation This modulation method will use 3-phase PWM and 2-phase PWM modulation in a random mode.

Modes	Name	IGBT Duty	Heat Losses	Torque Performance	Waveform Distortion	Motor Noise
0	3-Phase PWM	100%	High	High	Low	Low
1	2-Phase PWM	66.6%	Low	Low	High	High
2	Randomized PWM	Between mode0 & mode1	Medium	Medium	Medium	Medium

<b>11- 03</b>	<b>Carrier Frequency Reduction by temperature rise</b>
<b>Range</b>	<b>【0】 :Disable</b> <b>【1】 :Enable</b>

- When inverter (heat sink) temperature rises above 80°C the Carrier Frequency is reduced by 4K.
- When the temperature falls below less than 70°C, Carrier Frequency is reset to default.
- Temperature can be displayed by setting parameter 12-00=04000.

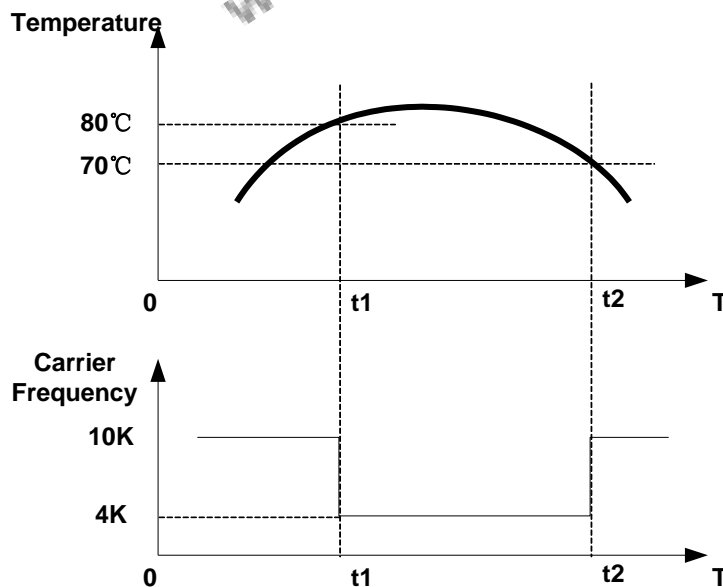

11- 04	S-Curve Acc 1
11- 05	S-Curve Acc 2
11- 06	S-Curve Dec 3
11- 07	S-Curve Dec 4
Range	<b>【0.0 ~ 4.0】 Sec</b>

- Use S Curve parameters where a smooth acceleration or deceleration action is required, this will prevent possible damage to driven machines by sudden acceleration/deceleration.

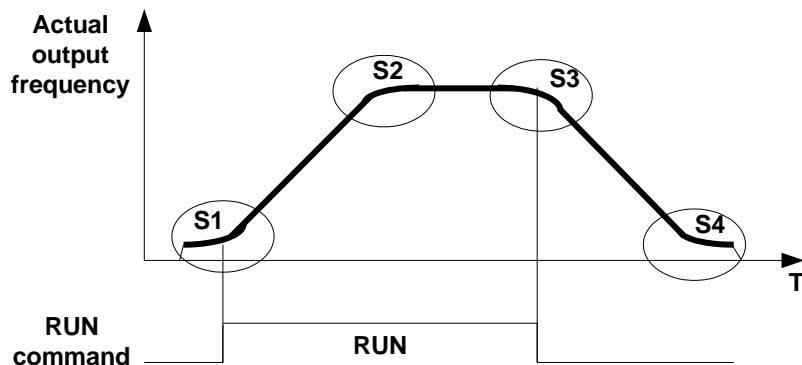

※ **Note:**

- Regardless of the stall prevention period, actual acceleration and deceleration time = preset acceleration / deceleration time + S curve time.
- Please set the required individual S curve times in the parameters (11-04~11-07)
- When S curve time (11-04~11-07) is set as 0, the S curve function is disabled.
- The calculation of S curve time is based on the Maximum output frequency of motor (01-02), Please refer to the parameter (00-14/00-15/00-16/00-17).

11- 08	Skip frequency 1
11- 09	Skip frequency 2
11-10	Skip frequency 3
Range	<b>【0.00 ~ 650.00】 Hz</b>
11-11	Skip frequency range ( $\pm$ frequency band)
Range	<b>【0.00 ~ 30.00】 Hz</b>

Skip frequency parameters can be used to avoid mechanical resonance in certain applications.

Example: 11-08=10.00(Hz); 11-09=20.00(Hz); 11-10=30.00(Hz); 11-11=2.00(Hz).

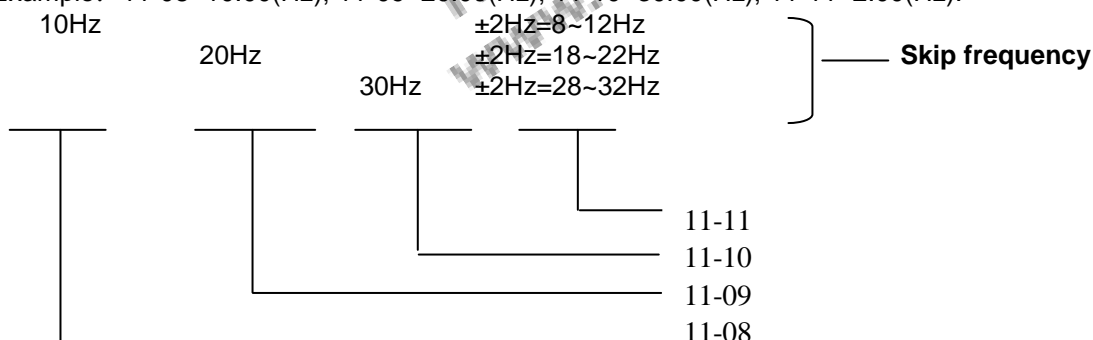

11- 12	V/F Energy Saving Gain (VF)
Range	<b>【0 ~ 100】 %</b>

11- 13	Regeneration Prevention Function
Range	<b>【0】 : Regeneration prevention function is disabled</b> <b>【1】 : Regeneration prevention function is enabled</b> <b>【2】 : Regeneration prevention function is enabled only during constant speed</b>

- Regeneration Prevention Function:  
During excessive energy regeneration, the Vpn (DC bus) voltage will Increase and lead to

OV (over voltage), to avoid over voltage due to regeneration the output frequency will be increased..  
Regeneration prevention function can be set according to the selections above.

Example: Regeneration prevention during acceleration.

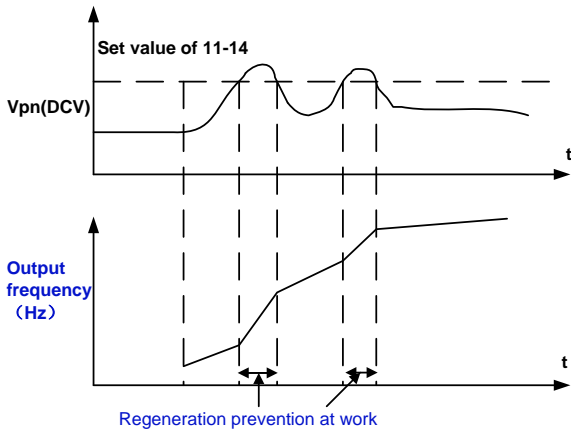

Example: Regeneration prevention during constant speed.

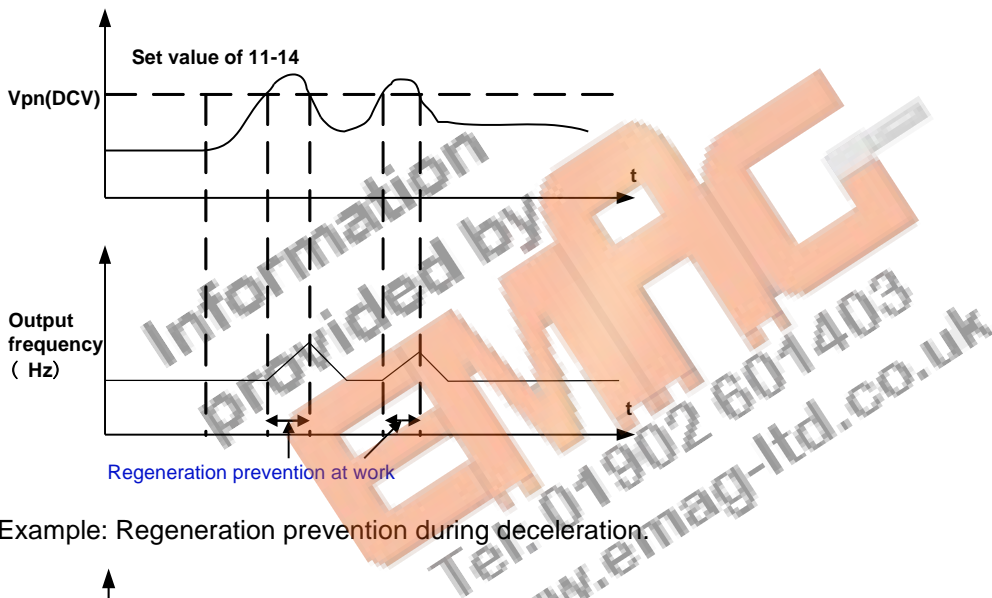

Example: Regeneration prevention during deceleration.

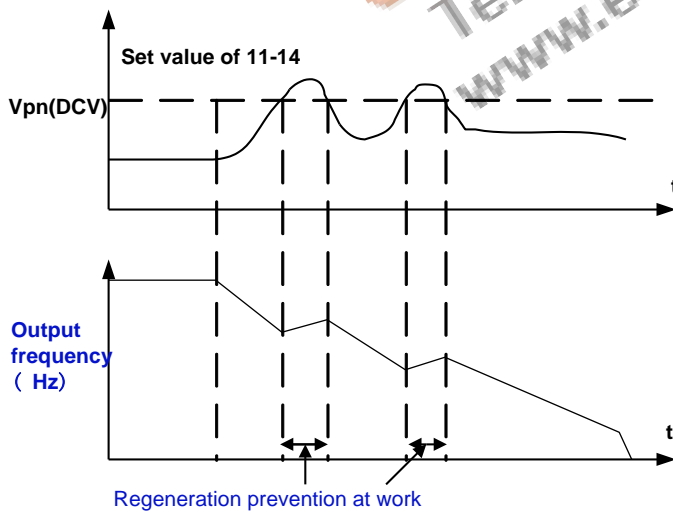



<b>11- 14</b>	<b>Regeneration Prevention Voltage Level</b>
<b>Range</b>	<b>【200V:300.0~400.0, 400V: 600.0~800.0】 V</b>

- Regeneration prevention voltage level: if the DC bus voltage level is set too low, then over-voltage protection will not be reached, but the actual deceleration time will be extended.

<b>11- 15</b>	<b>Regeneration Prevention Frequency Limit</b>
<b>Range</b>	<b>【0.00 ~ 15.00Hz】</b>

- Sets the regeneration **prevention** frequency limit.

<b>11- 16</b>	<b>Regeneration Prevention Voltage Gain</b>
<b>Range</b>	<b>【0~200】</b>

<b>11- 17</b>	<b>Regeneration Prevention Frequency Gain</b>
<b>Range</b>	<b>【0~200】</b>

- Regeneration avoidance function response can be improved by increasing 11-16/11-17. This will improve the response to voltage changes on the DC bus, but may cause output frequency instability. Set 11-16 as low as possible to reduce output frequency instability if this does not correct the instability then reduce the setting of parameter 11-17.
- Set 11-16 as low as possible to reduce the output frequency instability. If this does not correct the instability then reduce the setting of parameter 11-17, and re-adjust 11-16.

## 12 Monitor Function Group

<b>12- 00</b>	<b>Display Mode</b>
<b>Range</b>	<p>0 0 0 0 0</p> <p>MSD LSD</p> <p>00000~88888 Each digit can be set from 0 to 8 as listed below.</p> <p><b>【0】</b> :Disable display(frequency&amp; parameters)</p> <p><b>【1】</b> :output Current</p> <p><b>【2】</b> :output Voltage</p> <p><b>【3】</b> :DC voltage</p> <p><b>【4】</b> :Temperature</p> <p><b>【5】</b> :PID feedback</p> <p><b>【6】</b> :AI1</p> <p><b>【7】</b> :AI2</p> <p><b>【8】</b> :Count Status</p>

- MSD= Most significant digit. LSD= Least significant digit.

**Note:** MSD of parameter 12-00 sets the power on display; other digits set user selected displays.

<b>12- 01</b>	<b>PID Feedback Display format</b>
<b>Range</b>	<p><b>【0】</b> :Displayed in Integer (xxx)</p> <p><b>【1】</b> :One Decimal Place (xx.x)</p> <p><b>【2】</b> :Two Decimal Places (x.xx)</p>

<b>12- 02</b>	<b>PID Feedback Display Unit Setting</b>
<b>Range</b>	<p><b>【0】</b> :xxx--</p> <p><b>【1】</b> :xxxpb(pressure)</p> <p><b>【2】</b> :xxxfl(flow)</p>

<b>12- 03</b>	<b>Custom Units (Line Speed) Display Mode</b>
<b>Range</b>	<b>【0~65535】 Rpm</b>

- Set motor rated RPM in this parameter if required then the display will show this value when inverter output frequency reaches the motor name plate frequency. 50Hz or 60 Hz as appropriate.
- The line speed display is linearly proportional to the output frequency 0 to 50Hz or 0-60 Hz as

appropriate. Motor synchronous speed = 120 x Rated frequency/Number of poles.

<b>12- 04</b>	<b>Custom Units (Line Speed) Display Mode</b>
<b>Range</b>	<b>【0】 :Drive Output Frequency is Displayed</b> <b>【1】 :Line Speed is Displayed in Integer (xxxxx)</b> <b>【2】 :Line Speed is Displayed with One Decimal Place (xxxx.x)</b> <b>【3】 :Line Speed is Displayed with Two Decimal Places (xxx.xx)</b> <b>【4】 :Line Speed is Displayed with Three Decimal Places (xx.xxx)</b>

➤ **12- 04≠0**, line speed is displayed while the inverter is running or stopped.

<b>12- 05</b>	<b>Inputs and output Logic status display (S1 to S6) &amp; RY1~2</b>
<b>Range</b>	<b>Read only(Panel read only)</b>

➤ When any of S1 ~ S6 is turned on, corresponding segments on the digital display digits will be on.

➤ When relay output RY1/RY2 are on, the corresponding digit will be on as shown below.

Example 1: The following figure shows 12 - 05 display status,

when S1, S3, S5,S6 Inputs are ON and S2, S4, RY1 and RY2 are OFF.

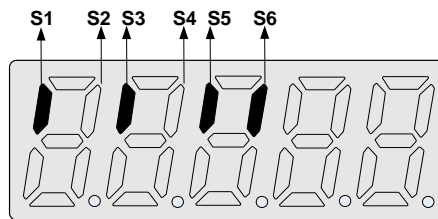

Example 2: The following figure shows 12 - 05 display status

when S2, S3, S4 inputs are ON and S1, S5,S 6 are OFF but RY1, RY2, PLC are ON.

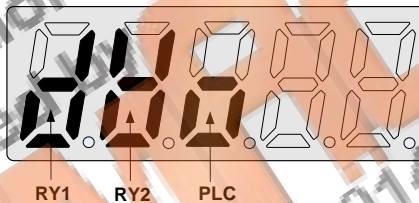

<b>12- 06</b>	<b>Alarm Selections for Inverter Components Life Expectancy</b>
<b>Range</b>	<b>xxxx0</b> : life alarm of inrush current suppression circuit is invalid
	<b>xxxx1</b> : life alarm of inrush current suppression circuit is valid
	<b>xxx0x</b> : life alarm of control circuit capacitors is invalid
	<b>xxx1x</b> : life alarm of control circuit capacitors is valid
	<b>xx0xx</b> : life alarm of main circuit capacitors is invalid
	<b>xx1xx</b> : life alarm of main circuit capacitors is valid

Example:set 12- 06=00111,if inrush current suppression circuit or control circuit capacitors or main circuit capacitors is damaged,display LIFE1,LIFE2,LIFE3 respectively. Alerts the user that inverter needs repair

<b>12- 08</b>	<b>Display of inrush current suppression circuit</b>
<b>Range</b>	<b>0~100</b>

➤ For every 1000 power on cycle, the percentage value will reduce by 1%. When this becomes lower than 30%, inverter displays "Life1".

<b>12- 09</b>	<b>Display of control circuit capacitors</b>
<b>Range</b>	<b>0~100</b>

➤ For every 80-hour operation, the percentage value will reduce by 1%. When this becomes lower than 5%, inverter displays "Life2".

<b>12- 11</b>	<b>Output current when Fault appeared</b>
<b>Range</b>	----
<b>12- 12</b>	<b>Output voltage when fault appeared</b>
<b>Range</b>	----
<b>12- 13</b>	<b>Output frequency when fault appeared</b>
<b>Range</b>	----
<b>12- 14</b>	<b>DC bus voltage when fault appeared</b>

<b>Range</b>	----
<b>12- 15</b>	<b>Frequency command when fault appeared</b>
<b>Range</b>	----

- In addition to the main circuit capacitors above, the theoretical value of life diagnosis are only for reference.

### 13 Inspection & Maintenance Functions

<b>13- 00</b>	<b>Drive Horsepower Code</b>
<b>Range</b>	----

Inverter Model:	13- 00 show	Inverter Model:	13- 00 show
E510-2P5-XXX	2P5	E510- 401-XXX	401
E510-201-XXX	201	E510- 402-XXX	402
E510-202-XXX	202	E510- 403-XXX	403
E510-203-XXX	203	E510- 405-XXX	405
E510-205-XXX	205	E510- 408-XXX	408
E510-208-XXX	208	E510- 410-XXX	410
E510-210-XXX	210	E510- 415-XXX	415
E510-215-XXX	215	E510- 420-XXX	420
E510-220-XXX	220	E510- 425-XXX	425

<b>13- 01</b>	<b>Software Version</b>
<b>Range</b>	----

<b>13- 02</b>	<b>Fault Log Display ( Latest 3 faults )</b>
<b>Range</b>	----

- Last three faults are stored in a stack and whenever there is a new fault the previous faults are pushed down the stack. So the fault stored in 2.xxx will be transferred to 3.xxx, and the one in 1.xxx to 2.xxx. The recent fault will be stored in the empty register 1.xxx.
- Use Up▲ and Down▼ keys to scroll between the fault registers.
- Pressing reset key when parameter 13-02 is displayed then all three fault registers will be cleared and the display for each register will change to 1. ---, 2. ---, 3. ---.
- E.g. fault log content is '1.OC-C'; this indicates the latest fault is OC-C, etc.

<b>13- 03</b>	<b>Accumulated Inverter Operation Time 1</b>
<b>Range</b>	<b>【0~23】 Hours</b>
<b>13- 04</b>	<b>Accumulated Inverter Operation Time 2</b>
<b>Range</b>	<b>【0~65535】 Days</b>
<b>13- 05</b>	<b>Accumulated Inverter Operation Time Mode</b>
<b>Range</b>	<b>【0】 :Power on time 【1】 :Operation time</b>

- When the operation time recorded in accumulator 1( Parameter 13-03) reaches 24 hours
- The recorded value in accumulator 2 parameter 13-04 changes to 1 day and the value in accumulator 1 is reset to 0000.

<b>13- 06</b>	<b>Parameter Lock</b>
<b>Range</b>	<b>【0】 :Enable all Functions 【1】 :Preset speeds 05- 01~05- 15 cannot be changed 【2】 :All Functions cannot be changed Except 05- 01~05- 16 【3】 :Disable All Function Except 13-06</b>

- When the 13-07=00000 (not set a password), you can adjust the parameters 05-01~ 05-016 from 13-06.

<b>13- 07</b>	<b>Parameter Lock Key Code</b>
<b>Range</b>	<b>【00000~65535】</b>

- When a parameter lock key number is entered in parameter 13-07. For any parameter modification the key number has to be entered.  
See following Parameter lock key setting example:-

- Setting Parameter lock key number example:

Step1:

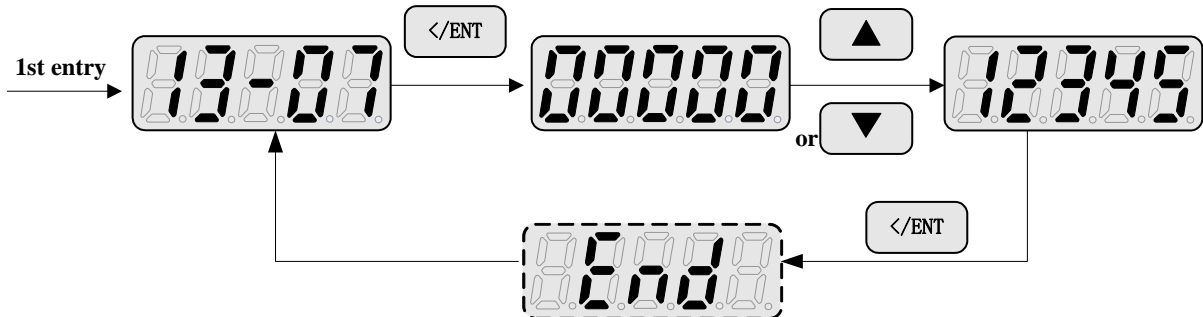

Step2:

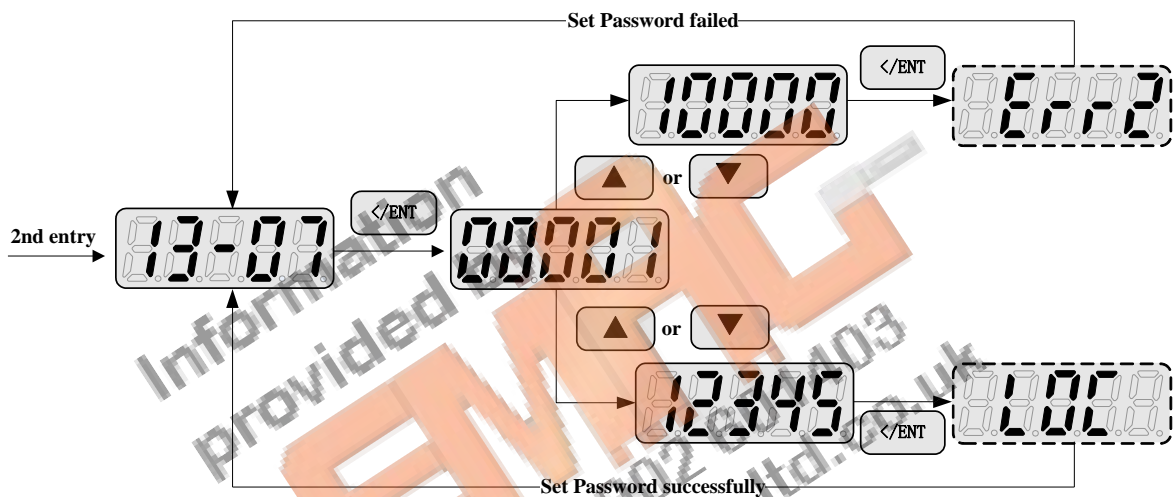

**Key code (password) unlock**

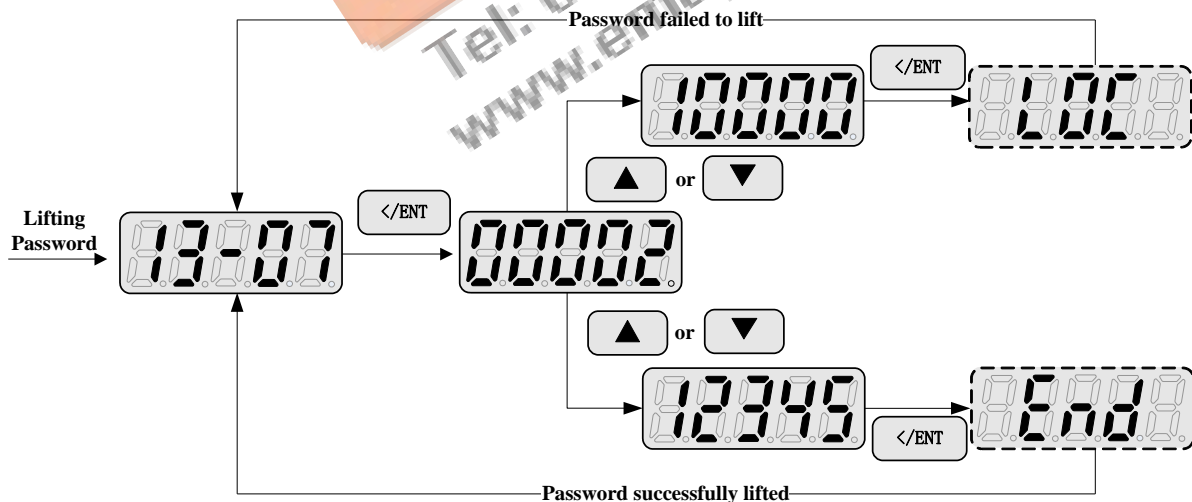

<b>13- 08</b>	<b>Reset Drive to Factory Settings</b>
<b>Range</b>	<b>【1150】 : Reset to factory setting. 50Hz system 【1160】 : Reset to factory setting. 60 Hz system. 【1112】 : RESET PLC</b>

- When a Parameter lock key number has been entered in parameter 13-07. This key number must be entered first before parameter 13-08 capable to be used.

## 14 PLC Setting function

14- 00	Setting value1 of T1
14- 01	Setting value1 of T1 (mode 7)
14- 02	Setting value1 of T2
14- 03	Setting value1 of T2 (mode 7)
14- 04	Setting value1 of T3
14- 05	Setting value1 of T3 (mode 7)
14- 06	Setting value1 of T4
14- 07	Setting value1 of T4 (mode 7)
14- 08	Setting value1 of T5
14- 09	Setting value1 of T5 (mode 7)
14- 10	Setting value1 of T6
14- 11	Setting value1 of T6 (mode 7)
14- 12	Setting value1 of T7
14- 13	Setting value1 of T7 (mode 7)
14- 14	Setting value1 of T8
14- 15	Setting value1 of T8 (mode 7)
<b>Range</b>	<b>【0-9999】</b>

➤ T1~T8 is 8 TIMER of built-in PLC.

14- 16	Setting value1 of C1
14- 17	Setting value1 of C2
14- 18	Setting value1 of C3
14- 19	Setting value1 of C4
14- 20	Setting value1 of C5
14- 21	Setting value1 of C6
14- 22	Setting value1 of C7
14- 23	Setting value1 of C8
<b>Range</b>	<b>【0-65535】</b>

➤ C1~C8 is 8 COUNTER of built-in PLC.

14- 24	Setting value1 of AS1
14- 25	Setting value2 of AS1
14- 26	Setting value3 of AS1
14- 27	Setting value1 of AS2
14- 28	Setting value2 of AS2
14- 29	Setting value3 of AS2
14- 30	Setting value1 of AS3
14- 31	Setting value2 of AS3
14- 32	Setting value3 of AS3
14- 33	Setting value1 of AS4
14- 34	Setting value2 of AS4
14- 35	Setting value3 of AS4
<b>Range</b>	<b>【0-65535】</b>

➤ AS1~AS4 is 4 Modified modules of built-in PLC.

14- 36	Setting value1 of MD1
14- 37	Setting value2 of MD1
14- 38	Setting value3 of MD1
14- 39	Setting value1 of MD2
14- 40	Setting value2 of MD2
14- 41	Setting value3 of MD2
14- 42	Setting value1 of MD3
14- 43	Setting value2 of MD3
14- 44	Setting value3 of MD3
14- 45	Setting value1 of MD4
14- 46	Setting value2 of MD4
14- 47	Setting value3 of MD4
<b>Range</b>	<b>【0-65535】</b>

- MD1~MD4 is 4 Multiplication modules of built-in PLC.

### 15 PLC Monitoring function

15- 00	Current value of T1
15- 01	Current value of T1(mode 7)
15- 02	Current value of T2
15- 03	Current value of T2(mode 7)
15- 04	Current value of T3
15- 05	Current value of T3(mode 7)
15- 06	Current value of T4
15- 07	Current value of T4(mode 7)
15- 08	Current value of T5
15- 09	Current value of T5(mode 7)
15- 10	Current value of T6
15- 11	Current value of T6(mode 7)
15- 12	Current value of T7
15- 13	Current value of T7(mode 7)
15- 14	Current value of T8
15- 15	Current value of T8(mode 7)
<b>Range</b>	<b>【0~9999】</b>

15-16	Current value of C1
15-17	Current value of C2
15-18	Current value of C3
15-19	Current value of C4
15-20	Current value of C5
15-21	Current value of C6
15-22	Current value of C7
15-23	Current value of C8
<b>Range</b>	<b>【0~65535】</b>

15-24	Current value of AS1
15-25	Current value of AS2
15-26	Current value of AS3
15-27	Current value of AS4
15-28	Current value of MD1
15-29	Current value of MD2
15-30	Current value of MD3
15-31	Current value of MD4
15-32	Current value of TD
<b>Range</b>	<b>【0~65535】</b>

- ※ **Note:** TD (15-32) displays the current value of the current PLC program execution time spent in units of  $\mu\text{s}$ .



## 4.4 Specification Description on Built-in PLC Function

PLC programs can be developed on PC (Windows base software) or PDA (WinCE base software) for download to E510.

E510 Inputs and outputs can be set for PLC functionality. Speed functions can be set using the built-in PLC functionality. .

PLC function is selected by setting inverter Run mode by parameter (00-00=3). Inputs can be set by parameters 03-00~03-05 = 24 (PLC Application).

### 4.4.1 Basic Instruction Set

	□	▲	▼	P	— —	—/—	NO / NC
Input Instruction					I	i	I1~I6 / i1~i6
Output Instruction	Q	Q	Q	Q	Q	q	Q1~Q2 / q1~q2
Auxiliary Instruction	M	M	M	M	M	m	M1~MF / m1~mF
Special Register							V1~V7
Counter Instruction	C				C	c	C1~C8 / c1~c8
Timer Instruction	T				T	t	T1~T8 / t1~t8
Analog Comparing Instruction	G				G	g	G1~G8 / g1~g8
Encoder Comparing Instruction	F				F	f	F1~F8 / f1~f8
ADD-DEC Instruction	AS						AS1~4
Mul-DIV Instruction	MD						MD1~4

Description for Special Register

V1: Setting Frequency	Range: 0.1~650.0Hz
V2: Operation Frequency	Range: 0.1~650.0Hz
V3: AI1 Input Value	Range: 0~1000
V4: AI2 Input Value	Range: 0~1000
V5: Keypad VR Input Value	Range: 0~1000
V6: Operation Current	Range: 0.1~999.9A
V7: Torque Value	Range: 0.1~200.0%

	Upper differential	Lower differential	Other Instruction Symbol
Differential Instruction	D	d	
SET Instruction			▲
RESET Instruction			▼
P Instruction			P

Open circuit (On status)	“ ”	
Short circuit (Off status)	“_”	

Connection symbol	Description
—	Connecting left and right Components
⊥	Connecting left, right and upper Components
⊕	Connecting left, right, upper and lower Components
⊓	Connecting left, right and lower Components

## 4.4.2 Function of Basic Instructions

### © Function D (d) Command

Sample 1: I1 – D —[ Q1

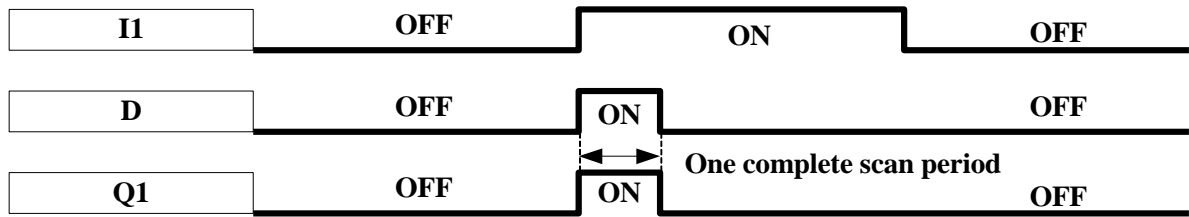

Sample 2: i1 – d —[Q1

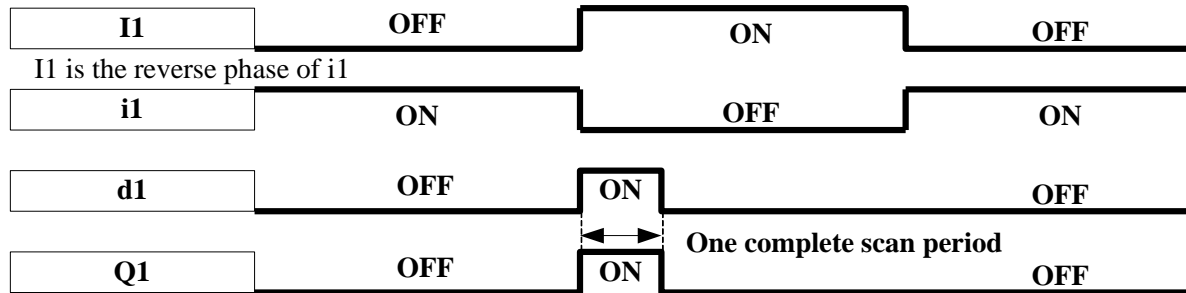

### ©© NORMAL ( - [ ] Output

I1 — [ Q1



### © SET ( ^ ) Output

I1 — ^ Q1



### © RESET ( v ) Output

I1 — v Q1

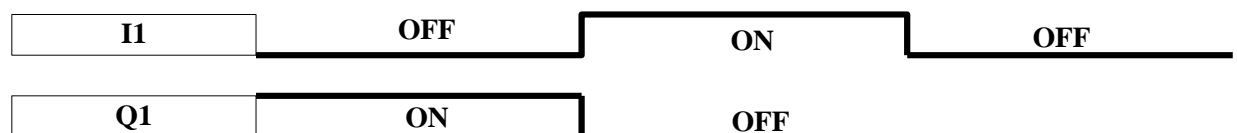

### © P Output

i1 — PQ1

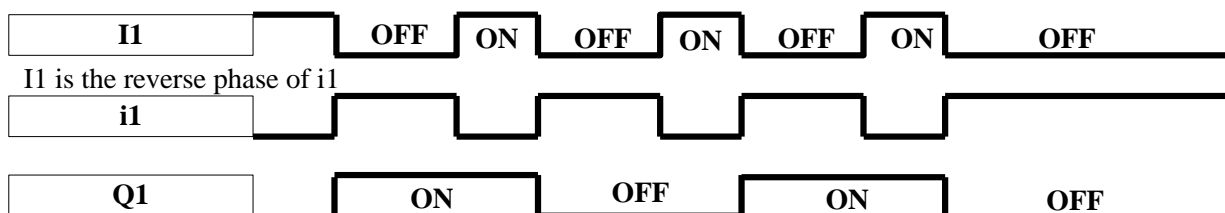

### 4.4.3 Application Instructions

#### 1. Counter

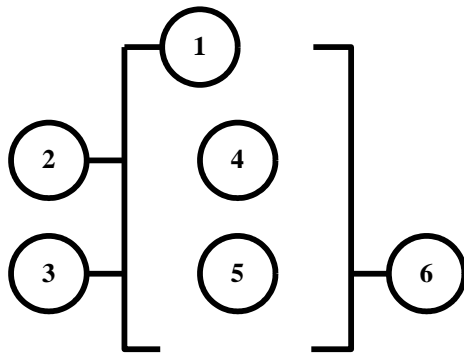

Symbol	Description
①	Counting Mode (1-4)
②	Use (I1 ~ f8) to set counting up or counting down
	OFF:counting up (0, 1, 2, 3, 4....) ON :counting down ( ...3, 2, 1, 0)
③	Use (I1 ~ F8) to RESET the counting value
	ON :the counter is initialized to zero andⓄOFF OFF: the counter continues to count
④	Present Counting Value
⑤	Target (Setting) Value(AS1~AS4,MD1~MD4,T1~T8,C1~C8,V1~V7,count)(0~65535)
⑥	Code of the counter (C1 ~ C4 total: 4 groups).

Mode 1:

The count value is locked to the set value, Off electricity didn't keep

Mode 2:

Count value unlocked, Off electricity didn't keep

Mode 3:

Count value locked, Off electricity keep

Mode 4:

Count value unlocked, Off electricity keep

#### (1) Counter Mode 1

① =1

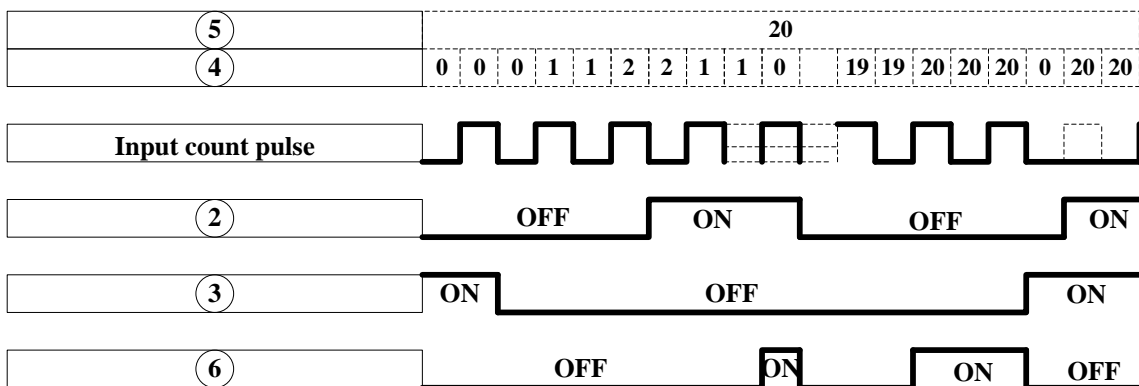

Sample:

**Input under the Ladder Program Mode**

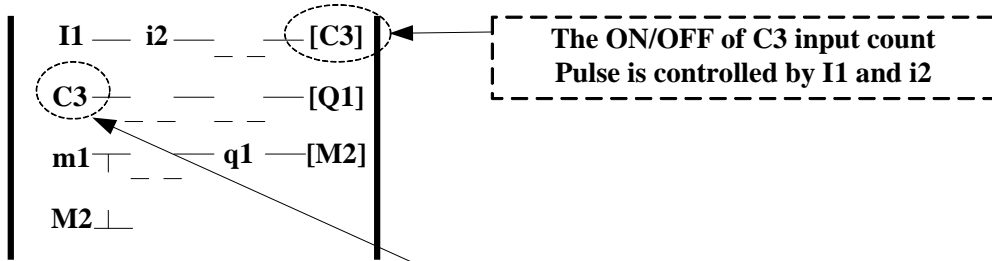

**Input under the function Program Mode**

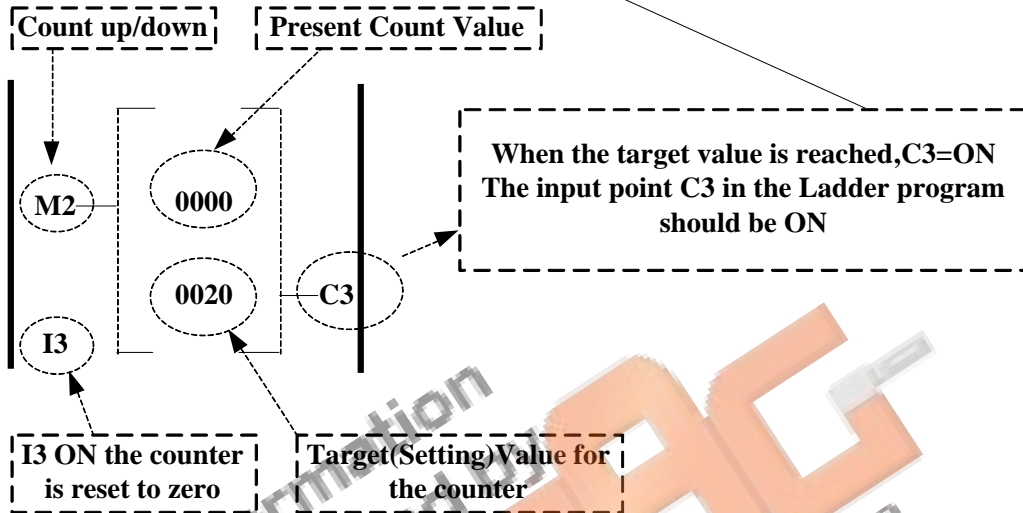

**(2) Counter Mode 2**

① =2

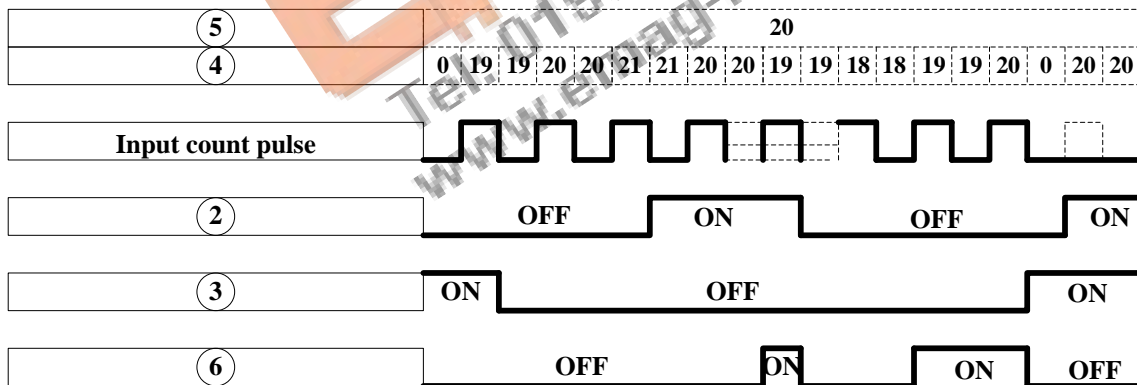

**Note:**

※ Under this Mode, the counting present value appeared will be greater than 20, unlike the Mode 1 in which the value is locked at 20.

(1) The counter Mode 3 is similar to the counter Mode 1 except that the former can save the value after the power is cut off and continue counting when the power is turned on at the next time

(2) The counter Mode 4 is similar to the counter Mode 2 except that the former can memory the recorded value after the power is cut off and continue counting when the power is turned on at the next time.

⑤	20												
④ Mode1&2	1	1	2	2					0	1	1	2	2
④ Mode3&4	1	1	2	2	3				3	4	4	5	5

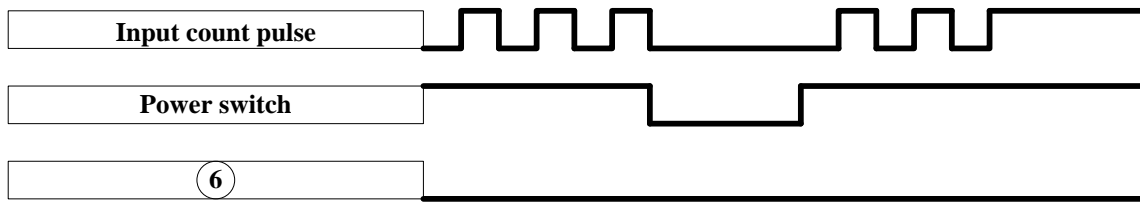

## 2. Timer

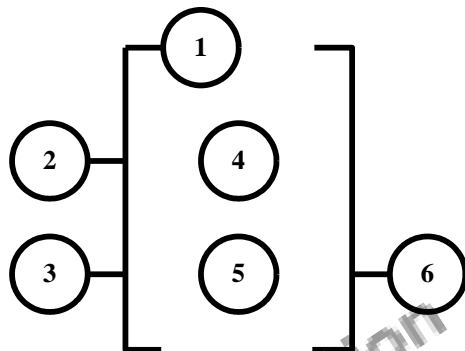

Symbol	Description
①	Timing Mode (1-7)
②	Timing unit: 1: 0.0 – 999.9 sec
	2: 0 – 9999 sec
	3: 0 – 9999 min
③	Use (I1 ~ I8) to RESET the timing value.
	ON: the counter is reset to zero and ⑥ OFF OFF: the counter continues to count
④	Present Timing Value
⑤	Target (setting) Timing Values(AS1~AS4,MD1~MD4,T1~T8, C1~C8,V1~V7,count)
⑥	The code of the Timer (T1 ~T8 total: 8 groups).

### (1) Timer Mode 1(ON-Delay Timer Mode1)

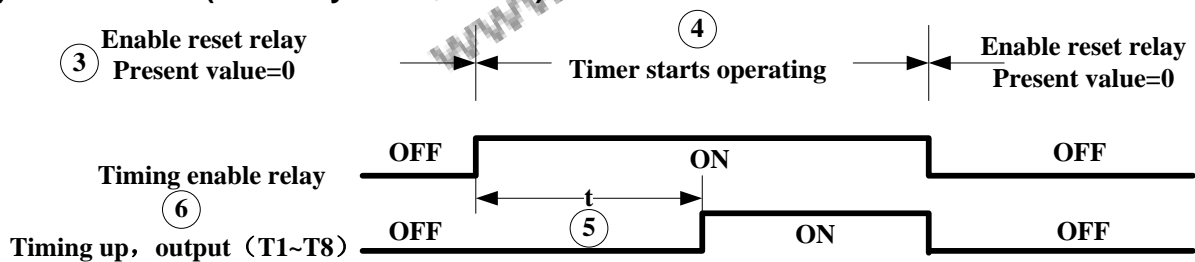

t=Target value set in the timer

**Sample:**

**Input under the Ladder Program Mode**

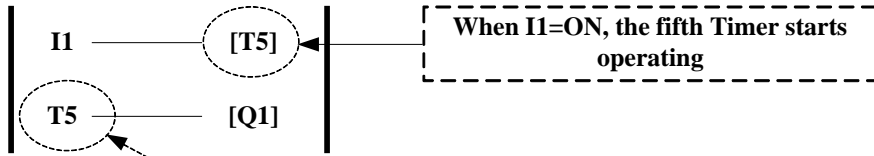

**Input under function Program Mode**

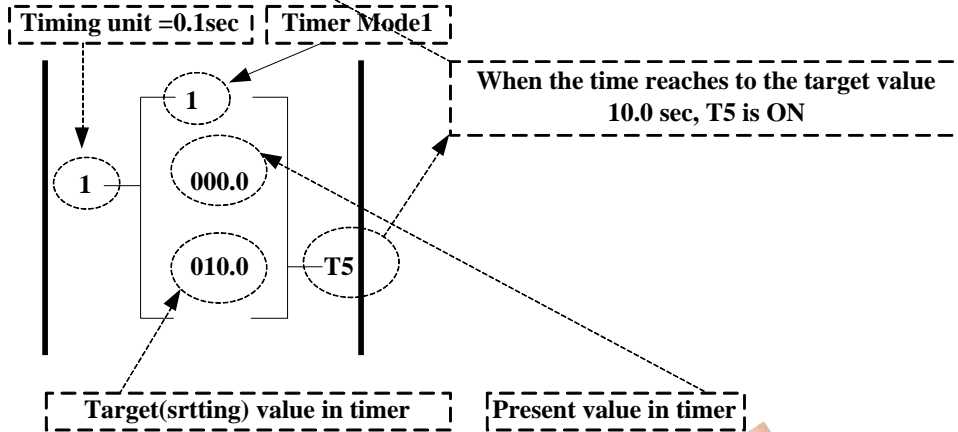

**(2) Timer Mode 2(ON-Delay Timer Mode2)**

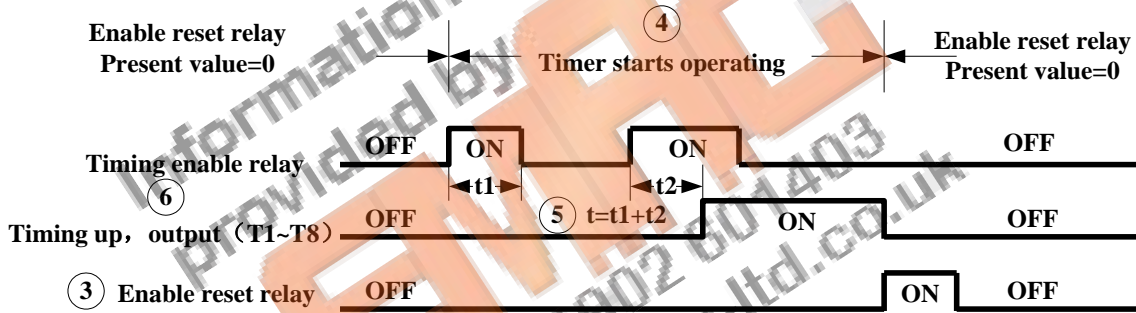

**(3) Timer Mode 3 (OFF-Delay Timer Mode1)**

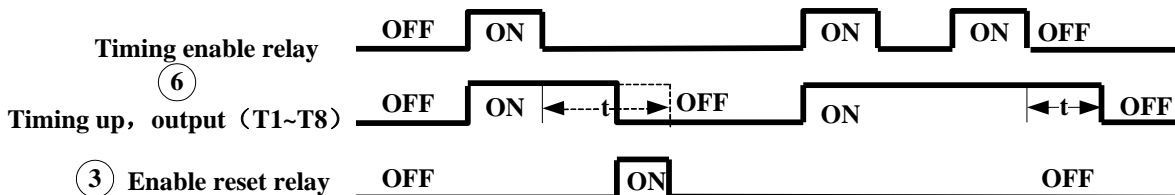
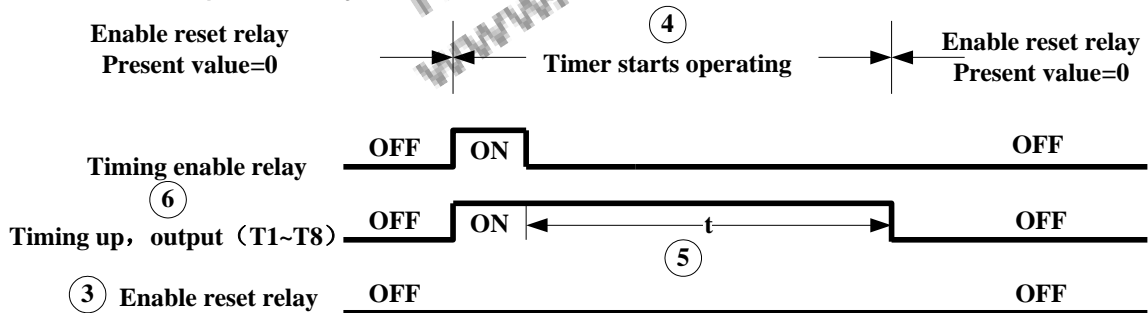

(4)



**(4) Timer Mode 4 (OFF-Delay Timer Mode 2)**

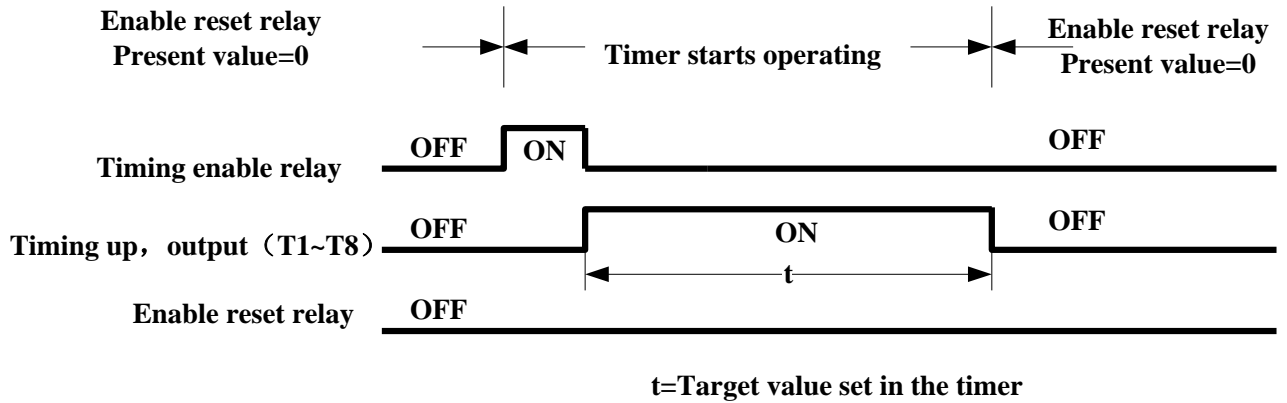

**(5) Timer Mode 5 (FLASH Timer Mode 1)**

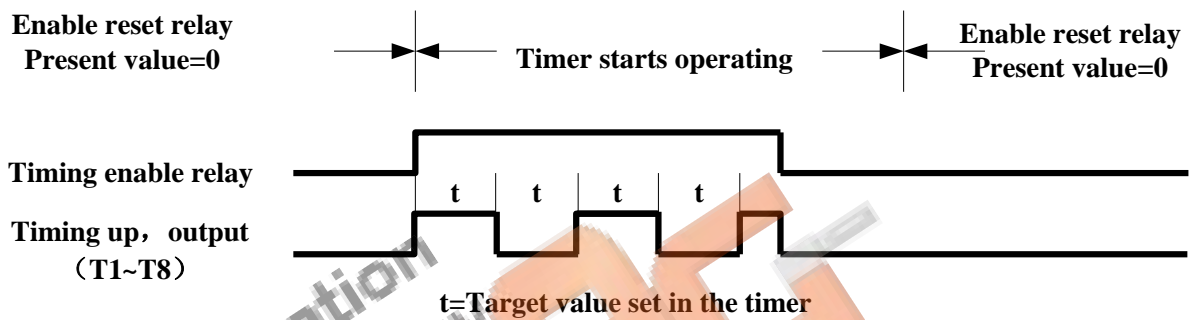

**(6) Timer Mode 6 (FLASH Timer Mode 2)**

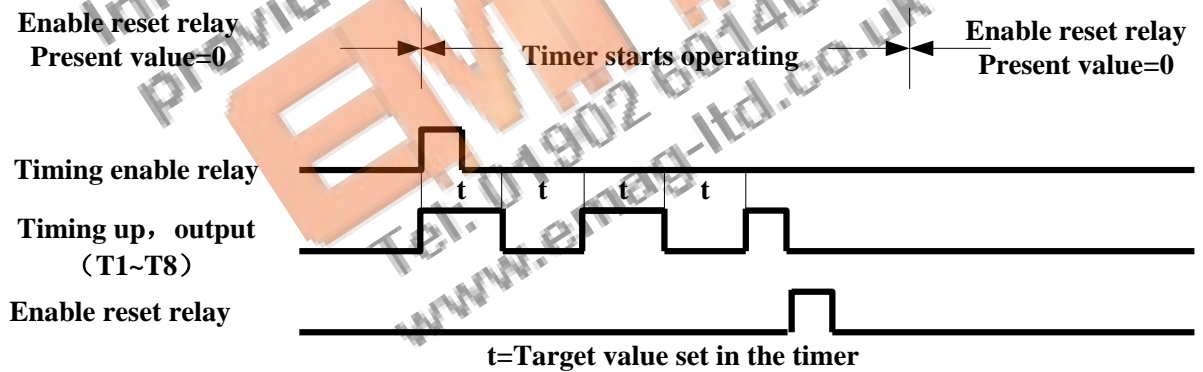

**(7) Timer Mode 7 (FLASH Timer Mode 3)**

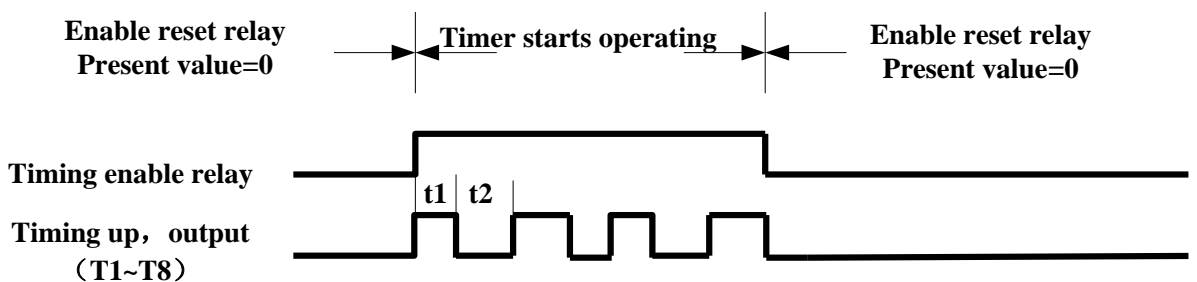

### 3. Analog comparator

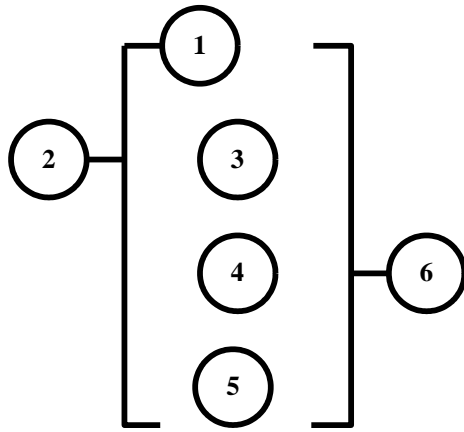

Symbol	Description
①	Analog comparison mode (1-3)
②	Selection of the input comparison value (AS1~AS4, MD1~MD4, T1~T8, C1~C8, V1~V7)
③	Setting reference comparison value (up limit)
④	Setting reference comparison value (Upper Limit) (AS1~AS4, MD1~MD4, T1~T8, C1~C8, V1~V7, count)
⑤	Setting reference comparison value (Lower Limit) (AS1~AS4, MD1~MD4, T1~T8, C1~C8, V1~V7, count)
⑥	Output terminals of analog comparator (G1~G4)

#### Analog Comparison Mode (1-3)

(1) Analog comparator mode 1 (③ ≤ ⑤, ⑥ ON)

##### Input under the Ladder Program Mode

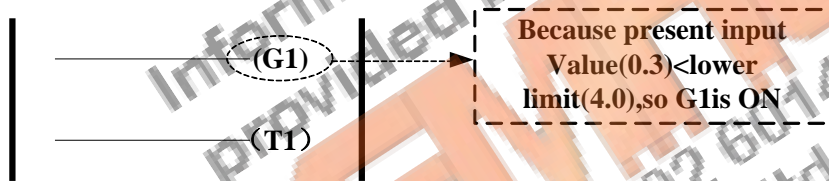

##### Input under the Function Program Mode

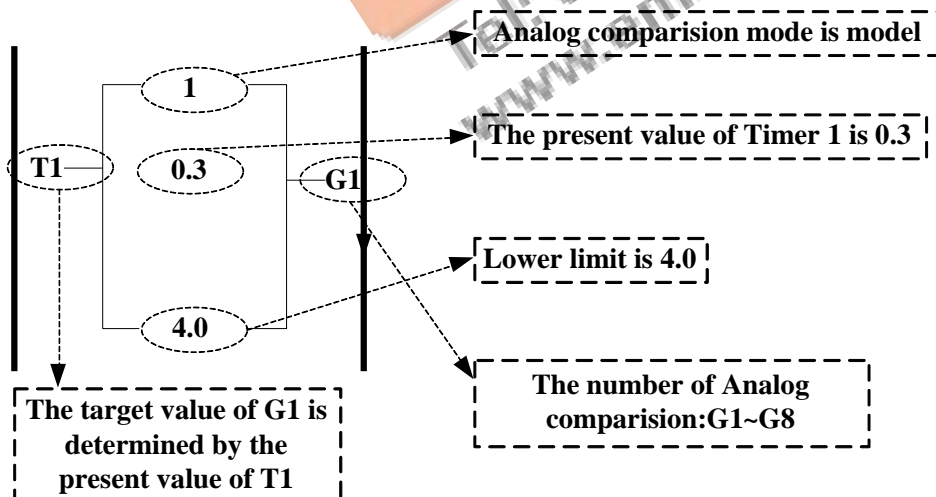

(2) Analog comparator mode 2 (③ ≥ ④, ⑥ ON)

(3) Analog comparator mode 3 (⑤ ≤ ③ ≤ ④, ⑥ ON)

## 4. Running Instruction

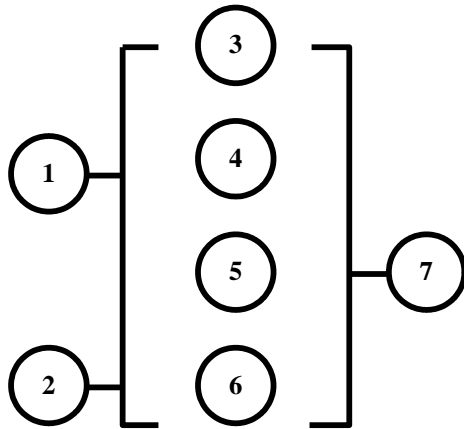

Symbol	Description
①	Running mode could be set via I1~f8 OFF:(FWD) ON:(REV)
②	Preset Speed could be set via I1~f8
	OFF:Operating at the frequency set on ③ ON:Operating at the frequency set on ④
③	Selected frequency for constant or V3, V4, V5
④	Selected Preset frequency for constant or V3, V4, V5
⑤	Acceleration Time (ACC Time)
⑥	Deceleration Time(DEC Time)
⑦	Instruction code of operation (F1~F8, Total: 8Groups)

Sample:

### Input under the Ladder Program Mode

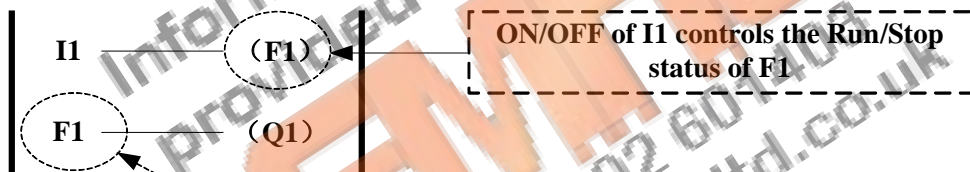

### Input under the Function Program Mode

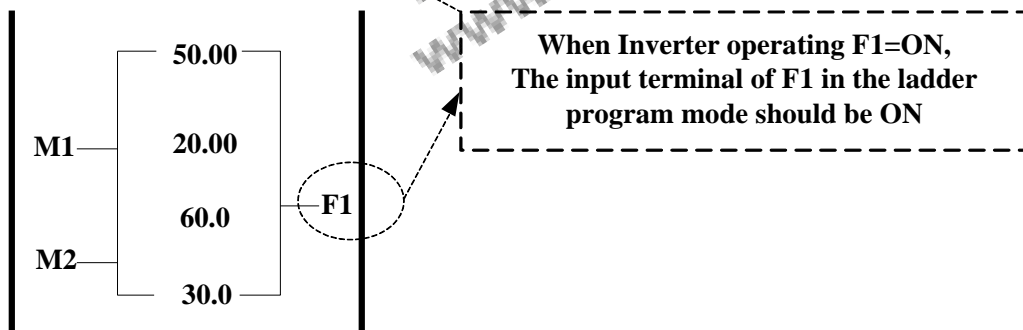

## 5. ACC- DEC module

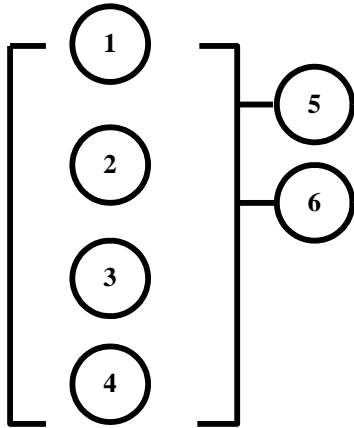

symbol	Description
①	Calculation results RESULT
②	addend V1(AS1~AS4,MD1~MD4,T1~T8,C1~C8,V1~V7, constant)
③	addend V2(AS1~AS4,MD1~MD4,T1~T8,C1~C8,V1~V7, constant)
④	filamentous V3(AS1~AS4,MD1~MD4,T1~T8,C1~C8,V1~V7, constant)
⑤	Error signal coil output (NOP /M1~MF)
⑥	Instruction code of ACC- DEC module

RESULT= V1+V2-V3

Sample:

**Input under the Ladder Program Mode**

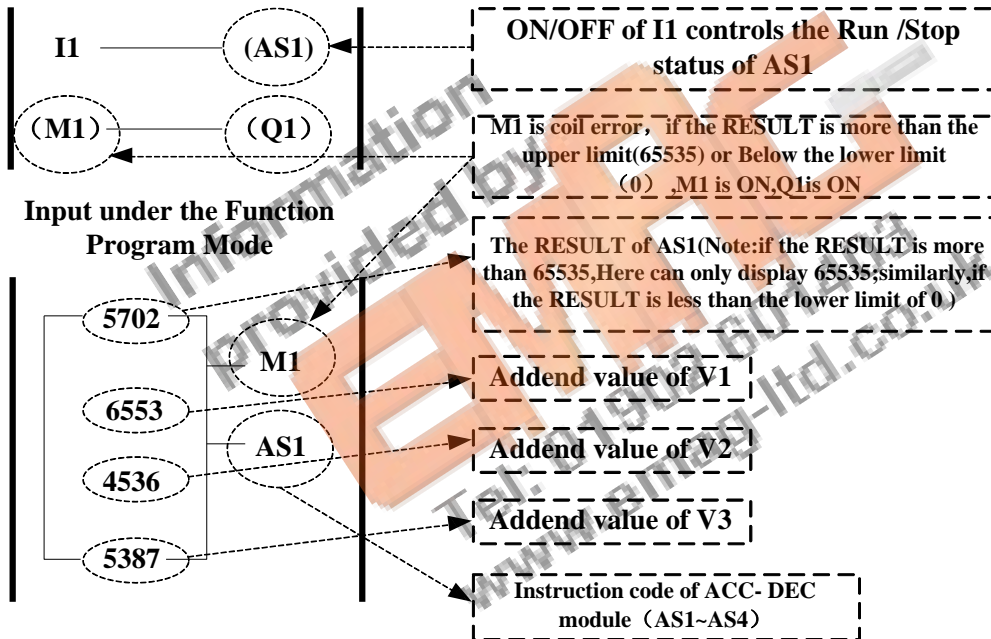

## 6. MUL- DIV module

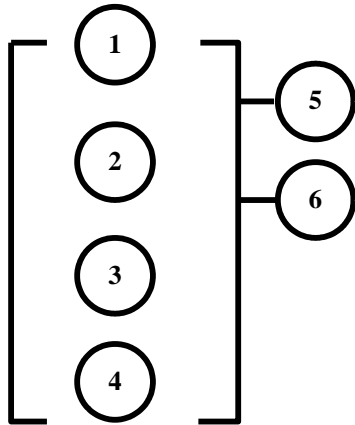

symbol	Description
①	Calculation results RESULT
②	multiplierA(AS1~AS4,MD1~MD4, T1~T8,C1~C8,V1~V7, constant)
③	multiplierB (AS1~AS4,MD1~MD4,T1~T8,C1~C8,V1~V7, constant)
④	divisor (AS1~AS4,MD1~MD4,T1~T8,C1~C8,V1~V7, constant)
⑤	Error signal coil output (NOP /M1~MF)
⑥	Instruction code of MUL- DIV module

$$\text{RESULT} = V1 * V2 / V3$$

Sample:

### Input under the Ladder Program Mode

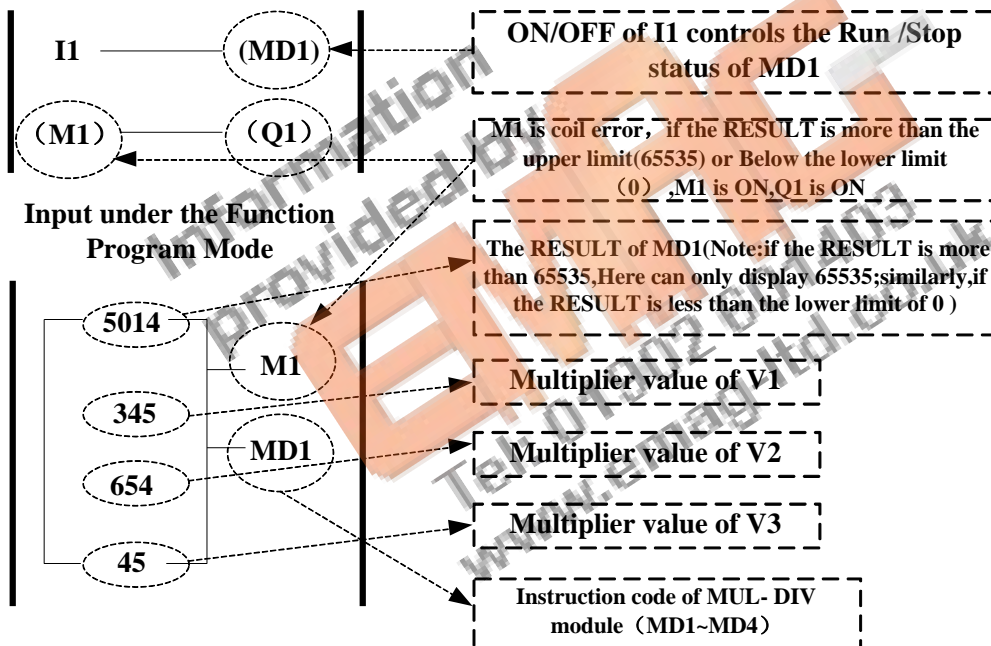

# Chapter 5 Troubleshooting and Maintenance

## 5.1 Error display and corrective action

### 5.1.1 Manual Reset and Auto-Reset

Faults which can not be recovered manually			
Display	Content	Cause	Corrective action
-OV-	Voltage too high when stopped	Detection circuit malfunction	Consult with the supplier
-OU-			
-LV-	Voltage too low when stopped	1. Power voltage too low 2. Pre-charge resistor or fuse burnt out. 3. Detection circuit malfunction	1. Check if the power voltage is correct 2. Replace the pre-charge resistor or the fuse 3. Consult with the supplier
-LU-			
-OH-	The inverter is overheated when stopped	1. Detection circuit malfunction 2. Ambient temperature too high or bad ventilation	Improve the ventilation conditions, if no result then replace the inverter
-OH-			
OH-C	The inverter is overheated during running	1. IGBT temperature is too high or bad ventilation 2. Temperature sensor error or circuit malfunctions	1. Reduce carrier frequency 2. Improve the ventilation conditions, if no result then replace the inverter
OH-C			
EPr	EEPROM problem	Faulty EEPROM	Consult with the supplier
EPr			
COt	Communication error	Communication disruption	Check the wiring
COt			
CtEr	Current Sensor detection error	Current sensor error or circuit malfunction	Consult with the supplier
CtEr			
Faults which can be recovered manually and automatically			
Display	Content	Cause	Corrective action
OC-A	Over-current at acceleration	1. Acceleration time too short 2. The capacity of the motor exceeds the capacity of the inverter 3. Short circuit between the motor coil and the case 4. Short circuit between motor wiring and ground 5. IGBT module damaged	1. Set a longer acceleration time 2. Replace inverter with one that has the same rating as that of the motor 3. Check the motor 4. Check the wiring 5. Consult with the supplier
OC-A			
OC-C	Over-current at fixed speed	1. Transient load change 2. Transient power change	1. Increase the capacity of the inverter 2. Install inductor on the power Supply input side
OC-C			
OC-d	Over-current at deceleration	The preset deceleration time is too short.	Set a longer deceleration time
OC-d			



Display	Content	Cause	Corrective action
OC-S	Over current at start	1. Short circuit between the motor coil and the case 2. Short circuit between motor coil and ground 3. the IGBT module damaged	1. Inspect the motor 2. Inspect the wiring 3. Consult with the supplier
OC-5			
OV-C	Excessive Voltage during operation/ deceleration	1. Deceleration time setting too short or excessive load inertia 2. Power voltage varies widely (fluctuates)	1. Set a longer deceleration time 2. Add a brake resistor or brake module 3. Add a reactor at the power input side
OU-C			
Err4	CPU Illegal interrupt	External noise	If it occurs too often, please consult with the supplier
Err4			
PF	Input phase Loss	Abnormal fluctuations in the main circuit voltage	1. Check the main circuit power supply wiring. 2. Check the power supply voltage
PF			
ud-C	Output under current detection	Output current < Output under current detection level	Set the level according to application
ud-C			
LF	Output phase loss	Loss of output voltage on any of the phases	1. Check output cable connection 2. Determine resistance between the lines 3. Check whether the terminals are loose
LF			
<b>Faults which can be recovered manually but not automatically</b>			
Display	Content	Cause	Corrective action
OC	Over-current during stop	Detection circuit malfunction	Consult with the supplier
OC			
OL1	Motor overload	loading too large	Consider increasing the Motor capacity
OL1			
OL2	Inverter overload	Excessive Load	Consider increasing the inverter capacity
OL2			
OL3	Over torque	1. Load too large 2. the setting of (8-15, 8-16) too small	1. Increase the inverter capacity 2. Set(8-15, 8-16) as needed
OL3			
LV-C	Voltage too low during operation	1. Power voltage too low 2. Power voltage varies widely (fluctuates)	1. Improve power quality 2. Consider adding a reactor at the power input side
LU-C			
OVSP	Motor rotating too fast	Rotation speed and the set speed value vary widely	1. Load may be too large 2. Check if the set speed is correct.
OVSP			
LIFE1	Inrush current suppression circuit life expectancy alarm	Inrush current suppression circuit is damaged	Consult with the supplier
LIFE1			

LIFE2 LIFE2	Control circuit capacitor life expectancy alarm	Control circuit capacitor is damaged	Consult with the supplier
LIFE3 LIFE3	Main Circuit Capacitor life expectancy alarm	Capacitor Main Circuit is damaged	Consult with the supplier
GF GF	Output side ground Fault	If ground fault detection is enabled by 08-18, then for any ground faults (short circuit to ground) the inverter output will switch off.	<ol style="list-style-type: none"> <li>1. Check the motor winding resistance for failures.</li> <li>2. Check the motor cable for ground short circuits</li> <li>3. If the above is correct, then consult with the supplier</li> </ol>

### 5.1.2 Keypad Operation Error Instruction

Display	Content	Cause	Corrective action
LOC LOC	<ol style="list-style-type: none"> <li>1. Parameter already locked</li> <li>2. Motor direction locked</li> <li>3. Parameter password(13 - 07) enabled</li> </ol>	<ol style="list-style-type: none"> <li>1. Attempt to modify frequency parameter while 13-06&gt;0.</li> <li>2. Attempt to reverse direction when 11- 00=1.</li> <li>3. Parameter (13 - 07) enabled, set the correct password will show LOC.</li> </ol>	<ol style="list-style-type: none"> <li>1. Adjust 13-06</li> <li>2. Adjust 11-00</li> </ol>
Err1 Err 1	Keypad operation error	<ol style="list-style-type: none"> <li>1. Press ▲ or ▼ while 00-05/00-06&gt;0 or running at preset speed.</li> <li>2. Attempt to modify the Parameter.Can not be modified during operation (refer to the parameter list).</li> </ol>	<ol style="list-style-type: none"> <li>1. The ▲ or▼ is available for modifying the parameter only when 00-05/00-06=0</li> <li>2. Modify the parameter in STOP mode.</li> </ol>
Err2 Err 2	Parameter setting error	<ol style="list-style-type: none"> <li>1. 00-13 is within the range of(11-08 ± 11-11) or (11-09 ± 11-11) or (11-10 ± 11-11)</li> <li>2. 00- 12≤00-13</li> <li>3. 00-05 = 00-06</li> </ol>	<ol style="list-style-type: none"> <li>1. Modify 11-08~11-10 or 11-11</li> <li>2. Set 00-12&gt;00-13</li> <li>3. Set 00-05 and 00-06 to different value</li> </ol>
Err5 Err 5	Modification of parameter is not available in communication	<ol style="list-style-type: none"> <li>1. Control command sent during communication.</li> <li>2. Attempt to modify the function 09-02 ~ 09-05 during communication</li> </ol>	<ol style="list-style-type: none"> <li>1. Issue enable command before communication</li> <li>2. Set parameters 09-02 ~ 09-05 function before communication</li> </ol>
Err6 Err 6	Communication failed	<ol style="list-style-type: none"> <li>1. Wiring error</li> <li>2. Communication parameter setting error.</li> <li>3. Incorrect communication protocol</li> </ol>	<ol style="list-style-type: none"> <li>1. Check hardware and wiring</li> <li>2. Check Functions (09-00~09- 05).</li> </ol>
Err7 Err 7	Parameter conflict	<ol style="list-style-type: none"> <li>1. Attempt to modify the function 13-00/13-08.</li> <li>2. Voltage and current detection circuit is abnormal.</li> </ol>	If reset is not possible, please consult with the supplier.

### 5.1.3 Special conditions

Display	Fault	Description
StP0 StP0	Zero speed at stop	Occurs when preset frequency <0.1Hz
StP1 StP1	Fail to start directly On power up.	If the inverter is set for external terminal control mode (00-02/00-03=1) and direct start is disabled (07-04=1) The inverter cannot be started and will flash STP1. The run input is active at power-up, refer to descriptions of (07-04).
StP2 StP2	Keypad Stop Operated when inverter in external Control mode.	If the Stop key is pressed while the inverter is set to external control mode (00-02/00-03=1) then 'STP2' flashes after stop. Release and re-activate the run contact to restart the inverter.
E.S. E.S.	External Rapid stop	When external rapid stop input is activated the inverter will decelerate to stop and the display will flash with E.S. message.
b.b. b.b.	External base block	When external base block input is activated the inverter stops immediately and then the display will flash with b.b. message.
PdEr PdEr	PID feedback loss	PID feedback loss is detected.
AtEr AtEr	Auto tuning error	1. Motor nameplate data Input errors. 2. Emergency stop is activated while auto tuning.
FlrE FlrE	Fire Mode	1. Software rev below 1.1, the fire mode is enabled when 08-17 = 1 2. Software ver 1.1 and above, the fire mode is enabled when 03-00~03-05 = 【28】 3. The display on the keypad indicates FlrE 4. Under fire mode function, the inverter will run at full speed

## 5.2 General troubleshooting

Status	Checking point	Remedy
<b>Motor runs in wrong direction</b>	Is the wiring for the output terminals correct?	Wiring must match U, V, and W terminals of the motor.
	Is the wiring for forward and reverse signals correct?	Check for correct wiring.
<b>The motor speed can not be regulated.</b>	Is the wiring for the analog frequency inputs correct?	Check for correct wiring.
	Is the setting of operation mode correct?	Check the Frequency Source set in parameters 00-05/00-06.
	Is the load too excessive?	Reduce the load.
<b>Motor running speed too high or too low</b>	Check the motor specifications (poles, voltage...) correct?	Confirm the motor specifications.
	Is the gear ratio correct?	Confirm the gear ratio.
	Is the setting of the highest output frequency correct?	Confirm the highest output frequency
<b>Motor speed varies unusually</b>	Is the load too excessive?	Reduce the load.
	Does the load vary excessively?	1. Minimize the variation of the load. 2. Consider increasing the capacities of the inverter and the motor.
	Is the input power erratic or is there a phase loss ?	1. Consider adding an AC reactor at the power input side if using single-phase power. 2. Check wiring if using three-phase power.
<b>Motor can not run</b>	Is the power connected to the correct L1(L), L2, and L3(N) terminals? is the charging indicator lit ?	1. Is the power applied ? 2. Turn the power OFF and then ON again. 3. Make sure the power voltage is correct. 4. Make sure screws are secured firmly.
	Is there voltage across the output terminals T1, T2, and T3?	Turn the power OFF and then ON again.
	Is overload causing the motor to stall?	Reduce the load so the motor will run.
	Are there any abnormalities in the inverter?	See error descriptions to check wiring and correct if necessary.
	Is there a forward or reverse run command ?	
	Has the analog frequency signal been input?	1. Is analog frequency input signal wiring correct? 2. Is voltage of frequency input correct?
	Is the operation mode setting correct?	Operate through the digital keypad

## 5.3 Troubleshooting of the Inverter

Refer to the error display and corrective action section 5.1.

## 5.4 Routine and periodic inspection

To ensure stable and safe operation, check and maintain the inverter at regular intervals.

Use the checklist below to carry out inspection.

Disconnect power after approximately 5 minutes to make sure no voltage is present on the output terminals before any inspection or maintenance.

Items	Details	Checking period		Methods	Criteria	Remedies
		Daily	1Year			
<b>Environment &amp; Ground connection</b>						
Ambient conditions at the installation	Confirm the temperature and humidity at the machine	☉		Measure with thermometer and hygrometer	Temperature: -10 – 40oC (14-120°F) Humidity: Below 95%RH	Improve the ambient or relocate the drive to a better area.
	Are there inflammable materials in the vicinity?	☉		Visual check	Keep area clear	
Installation Grounding	Any unusual vibration from the machine	☉		Visual, hearing check	Keep area clear	Secure screws
	Is the grounding resistance correct?		☉	Measure the resistance with a multi-tester	200Vclass: below 100Ω	Improve the grounding if needed.
<b>Terminals &amp; Wiring</b>						
Connection terminals	Any loose parts or terminals?		☉	Visual check Check with a screwdriver	Correct installation requirement	Secure terminals and remove rust
	Any damage to the base ?		☉			
	Any corroded Terminals?		☉			
Wiring	Any broken wires?		☉	Visual check	Correct wiring requirement	Rectify as necessary
	Any damage to the wire insulation?		☉			
<b>Voltage</b>						
Input power voltage	Is the voltage of the main circuit correct?	☉		Measure the voltage with a multi-tester	Voltage must conform with the spec.	Improve input voltage if necessary.
<b>Circuit boards and components</b>						
Printed circuit board	Any contamination or damage to printed circuit board?		☉	Visual check	Correct component condition	Clean or replace the circuit board
	Discolored, overheated, or burned parts		☉			
Capacitor	Any unusual odor or leakage	☉				
	Any physical damage or protrusion		☉			
Power component	Any dust or debris		☉			Clean components
	Check resistance between each terminals		☉	Measure with a multi-tester	No short circuit or broken circuit in three-phase output	Consult with the supplier



Peripheral device						
Rheostat	Whether rheostat wiring or connector are damaged		⊙	Visual check	No abnormalities	Replacement rheostat
Electromagnetic Contactor	Check contacts and connections for any abnormality.	⊙				Replacement Contactor
	Unusual vibration and noise	⊙		hearing check		
Reactor	Is there any abnormalities?	⊙		Visual check		Replacement Reactor
Cooling System						
Cooling fan	Unusual vibration and noise		⊙	Visual or hearing check	Correct cooling	Consult with the supplier
	Excessive dust or debris	⊙				Clean the fan
Heat sink	Excessive dust or debris	⊙		Visual check		Clean up debris or dust
Ventilation Path	Is the ventilation path blocked?	⊙				Clear the path

## 5.5 Maintenance

To ensure long-term reliability, follow the instructions below to perform regular inspection. Turn the power off and wait for a minimum of 5 minutes before inspection to avoid potential shock hazard from the charge stored in high-capacity capacitors.

### 1. Maintenance Check List

➤ Ensure that temperature and humidity around the inverters is as required in the instruction manual, installed away from any sources of heat and the correct ventilation is provided..
➤ For replacement of a failed or damaged inverter consult with the local supplier.
➤ Ensure that the installation area is free from dust and any other contamination.
➤ Check and ensure that the ground connections are secure and correct.
➤ Terminal screws must be tight, especially on the power input and output of the inverter.
➤ Do not perform any insulation test on the control circuit.

### 2. Insulation test Method

#### Single Phase

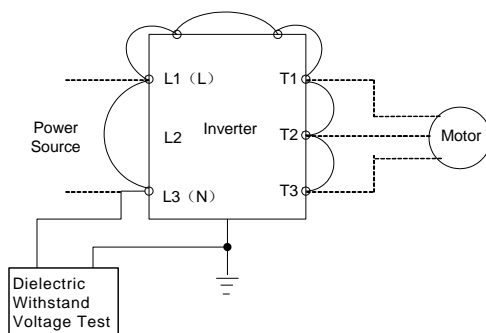

#### Three Phase

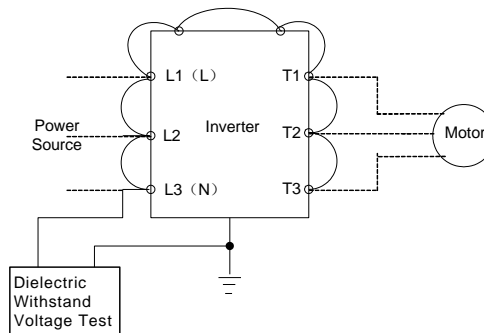



# Chapter 6 Peripherals Components

## 6.1 Reactor Specifications

Model: E510-□□□-XXX	Specification	
	Current (A)	Inductance (mH)
2P5	8.5	2.1
201	12	2.1
202	19.0	1.1
203	25.0	0.71
205	20	0.53
208	33.0	0.35
210	42.0	0.265
215	60	0.18
220	80	0.13

Model: E510-□□□-XXX	Specification	
	Current (A)	Inductance (mH)
401	4.5	8.4
402	6	4.2
403	7.5	3.6
405	12	2.2
408	17.0	1.42
410	23.0	1.06
415	31.0	0.7
420	40	0.53
425	50	0.42

## 6.2 Electromagnetic Contactor Circuit Breaker

Model: E510-□□□-XXX	Molded-case circuit breaker made by TECO	Magnetic contactor (MC) made by TECO
2P5	TO-50E 15A	CN-11
201/202	TO-50E 20A	
203/205	TO-50E 30A	
208	TO-50E 50A	CN-18
210	TO-100S 60A	CN-25
215	TO-100S 100A	CN-50
220	TO-100S 100A	CN-60
401/402/403/405	TO-50E 15A	CN-11
408	TO-50E 20A	CN-16
410	TO-50E 30A	CN-18
415	TO-50E 50A	CN-25
420	TO-100S 50A	CN-35
425	TO-100S 75A	CN-50

### 6.3 Fuse Specification

Model: E510-□□□-XXX	Fuse types
2P5/201	15A, 300VAC
202/203	30A, 300VAC
205	30A, 300VAC
208/210	60A, 300VAC
215/220	100A, 300VAC
401	5 A, 600VAC
402	10A, 600VAC
403	15A, 600VAC
405	20A, 600VAC
408/410	40A, 600VAC
415	70A, 600VAC

### 6.4 Fuse Specification (UL Model Recommended)

Model	Manufacture	Type	Rating
E510-2P5-H1XX	Bussmann	20CT	690V 20A
E510-201-H1XX	Bussmann	20CT	690V 20A
E510-202-H1XX	Bussmann	30FE	690V 30A
E510-203-H1XX	Bussmann	50FE	690V 50A
E510-2P5-H3XX	Bussmann	20CT	690V 20A
E510-201-H3XX	Bussmann	20CT	690V 20A
E510-202-H3XX	Bussmann	20CT	690V 20A
E510-203-H3XX	Bussmann	30FE	690V 30A
E510-205-H3XX	Bussmann	50FE	690V 50A
E510-208-H3XX	Bussmann	63FE	690V 63A
E510-210-H3XX	FERRAZ SHAWMUT	A50QS100-4	500V 100A
E510-215-H3XX	Bussmann or FERRAZ SHAWMUT	120FEE A50QS150-4	690V 120A 500V 150A
E510-220-H3XX	FERRAZ SHAWMUT	A50QS150-4	500V 150A
E510-401-H3XX	Bussmann	10CT	690V 10A
E510-402-H3XX	Bussmann	16CT	690V 16A
E510-403-H3XX	Bussmann	16CT	690V 16A
E510-405-H3XX	Bussmann	25ET	690V 25A
E510-408-H3XX	Bussmann	40FE	690V 40A
E510-410-H3XX	Bussmann	50FE	690V 50A
E510-415-H3XX	Bussmann	63FE	690V 63A
E510-420-H3XX	Bussmann	80FE	690V 80A
E510-425-H3XX	FERRAZ SHAWMUT	A50QS100-4	500V 100A

## 6.5 Brake Resistor

Model: E510-□□□-XXX	Horse (HP)	Motor Capacity (KW)	Specification		ED(%)	Brake Torque (%)	Minimum Resistance	
			(W)	(Ω)			(W)	(Ω)
2P5	0.5	0.4	80	200	10	214	210	70
201	1	0.75	80	200	10	117	210	70
202	2	1.5	150	100	10	117	210	70
203	3	2.2	200	80	10	112	210	70
205	5	3.7	390	40	10	117	500	30
208	7.5	5.5	500	30	10	123	600	25
210	10	7.5	780	20	10	117	1000	15
215	15	11	1200	13.6	10	100	1500	10
220	20	15	1200	13.6	10	100	1500	10
401	1	0.75	80	750	10	123	500	120
402	2	1.5	150	400	10	117	500	120
403	3	2.2	250	250	10	123	600	100
405	5	3.7	400	150	10	123	1000	60
408	7.5	5.5	500	130	10	123	1200	50
410	10	7.5	600	100	10	117	1200	50
415	15	11	1000	60	10	149	1200	50
420	20	15	1500	40	10	100	2400	25
425	25	18.5	2000	32	10	120	4000	15

※Note: Formula for brake resistor:  $W = (V_{pnb} * V_{pnb}) * ED\% / R_{min}$

1. W: braking resistor power (Watts)
2.  $V_{pnb}$ : braking voltage (220V=380VDC, 440V=760VDC)
3. ED%: braking effective period
4.  $R_{min}$ : braking resistor minimum value (ohms)

## 6.6 Input Noise filter

Frame	model	rated input	Noise filter model name	rated current (A)
1	E510-2P5-H	1 $\psi$ 200 ~ 240V 3 $\psi$ 200 ~ 240V	<b>E2F-2102</b> <b>FN3258-16-45</b>	10 16
1	E510-201-H	1 $\psi$ 200 ~ 240V 3 $\psi$ 200 ~ 240V	<b>E2F-2102</b> <b>FN3258-16-45</b>	10 16
2	E510-202-H	1 $\psi$ 200 ~ 240V 3 $\psi$ 200 ~ 240V	<b>FS6146-27-07</b> <b>FN3258-16-45</b>	27 16
2	E510-203-H	1 $\psi$ 200 ~ 240V 3 $\psi$ 200 ~ 240V	<b>FS6146-27-07</b> <b>FN3258-16-45</b>	27 16
1	E510-202-H3	3 $\psi$ 200 ~ 240V	<b>FN3258-16-45</b>	16
2	E510-205-H3	3 $\psi$ 200 ~ 240V	<b>FS20500-22-99</b>	22
3	E510-208-H3	3 $\psi$ 200 ~ 240V	<b>T-096.05001.00</b>	50
3	E510-210-H3	3 $\psi$ 200 ~ 240V	<b>T-096.05001.00</b>	50
4	E510-215-H3	3 $\psi$ 200 ~ 240V	<b>T-097.08004.00</b>	80
4	E510-220-H3	3 $\psi$ 200 ~ 240V	<b>T-097.08004.00</b>	80
1	E510-401-H3	3 $\psi$ 380 ~ 480V	<b>FN3258-16-45</b>	16
1	E510-402-H3	3 $\psi$ 380 ~ 480V	<b>FN3258-16-45</b>	16
2	E510-403-H3	3 $\psi$ 380 ~ 480V	<b>FN3258-16-45</b>	16
2	E510-405-H3	3 $\psi$ 380 ~ 480V	<b>FN3258-16-45</b>	16
3	E510-408-H3	3 $\psi$ 380 ~ 480V	<b>T-097.08004.00</b>	80
3	E510-410-H3	3 $\psi$ 380 ~ 480V	<b>T-097.08004.00</b>	80
3	E510-415-H3	3 $\psi$ 380 ~ 480V	<b>T-097.08004.00</b>	80
4	E510-420-H3	3 $\psi$ 380 ~ 480V	<b>FS42500-50-99</b>	80
4	E510-425-H3	3 $\psi$ 380 ~ 480V	<b>FS42500-50-99</b>	80

\*Note : The above models are not build-in filter.

## Appendix-1 Instructions for UL

### ◆ Safety Precautions

#### DANGER

##### Electrical Shock Hazard

**Do not connect or disconnect wiring while the power is on.**

Failure to comply will result in death or serious injury.

#### WARNING

##### Electrical Shock Hazard

**Do not operate equipment with covers removed.**

Failure to comply could result in death or serious injury.

The diagrams in this section may show drives without covers or safety shields to show details. Be sure to reinstall covers or shields before operating the drives and run the drives according to the instructions described in this manual.

**Always ground the motor-side grounding terminal.**

Improper equipment grounding could result in death or serious injury by contacting the motor case.

**Do not touch any terminals before the capacitors have fully discharged.**

Failure to comply could result in death or serious injury.

Before wiring terminals, disconnect all power to the equipment. The internal capacitor remains charged even after the power supply is turned off. After shutting off the power, wait for at least the amount of time specified on the drive before touching any components.

**Do not allow unqualified personnel to perform work on the drive.**

Failure to comply could result in death or serious injury.

Installation, maintenance, inspection, and servicing must be performed only by authorized personnel familiar with installation, adjustment, and maintenance of AC drives.

**Do not perform work on the drive while wearing loose clothing, jewelry, or lack of eye protection.**

Failure to comply could result in death or serious injury.

Remove all metal objects such as watches and rings, secure loose clothing, and wear eye protection before beginning work on the drive.

**Do not remove covers or touch circuit boards while the power is on.**

Failure to comply could result in death or serious injury.

##### Fire Hazard

**Tighten all terminal screws to the specified tightening torque.**

Loose electrical connections could result in death or serious injury by fire due to overheating of electrical connections.

**Do not use an improper voltage source.**

Failure to comply could result in death or serious injury by fire.

Verify that the rated voltage of the drive matches the voltage of the incoming power supply before applying power.

**Do not use improper combustible materials.**

Failure to comply could result in death or serious injury by fire.

Attach the drive to metal or other noncombustible material.

#### NOTICE

**Observe proper electrostatic discharge procedures (ESD) when handling the drive and circuit boards.**

Failure to comply may result in ESD damage to the drive circuitry.

**Never connect or disconnect the motor from the drive while the drive is outputting voltage.**

Improper equipment sequencing could result in damage to the drive.

**Do not use unshielded cable for control wiring.**

Failure to comply may cause electrical interference resulting in poor system performance. Use shielded twisted-pair wires and ground the shield to the ground terminal of the drive.

**NOTICE**

**Do not modify the drive circuitry.**

Failure to comply could result in damage to the drive and will void warranty.

Teco is not responsible for any modification of the product made by the user. This product must not be modified.

**Check all the wiring to ensure that all connections are correct after installing the drive and connecting any other devices.**

Failure to comply could result in damage to the drive.

◆ **UL Standards**

The UL/cUL mark applies to products in the United States and Canada and it means that UL has performed product testing and evaluation and determined that their stringent standards for product safety have been met. For a product to receive UL certification, all components inside that product must also receive UL certification.



◆ **UL Standards Compliance**

This drive is tested in accordance with UL standard UL508C and complies with UL requirements. To ensure continued compliance when using this drive in combination with other equipment, meet the following conditions:

■ **Installation Area**

Do not install the drive to an area greater than pollution severity 2 (UL standard).

■ **Main Circuit Terminal Wiring**

UL approval requires crimp terminals when wiring the drive's main circuit terminals. Use crimping tools as specified by the crimp terminal manufacturer. Teco recommends crimp terminals made by NICHIFU for the insulation cap.

The table below matches drives models with crimp terminals and insulation caps. Orders can be placed with a Teco representative or directly with the Teco sales department.

**Closed-Loop Crimp Terminal Size**

Drive Model E510	Wire Gauge mm <sup>2</sup> (AWG) (min)		Terminal	Crimp Terminal	Tool	Insulation Cap
	R/L1 · S/L2 · T/L3	U/T1 · V/T2 · W/T3	Screws	Model No.	Machine No.	Model No.
201	2.1 (14)		M3.5	R2-3.5	Nichifu NH 1 / 9	TIC 2
202	3.3 (12)		M4	R3.5-4	Nichifu NH 1 / 9	TIC 3.5
202-H3	2.1 (14)		M3.5	R2-3.5	Nichifu NH 1 / 9	TIC 2
205	5.3 (10)		M4	R5.5-4	Nichifu NH 1 / 9	TIC 5.5
210	8.4 (8)		M5	R8-5	Nichifu NH 1 / 9	TIC 8
220	21.2 (4)		M5	R22-5	Nichifu NOP 150H	TIC 22
402	2.1 (14)		M3.5	R2-3.5	Nichifu NH 1 / 9	TIC 2
405	2.1 (14)		M4	R2-3.5	Nichifu NH 1 / 9	TIC 2
415	8.4 (8)		M5	R8-5	Nichifu NH 1 / 9	TIC 8
425	8.4 (8)		M5	R8-5	Nichifu NH 1 / 9	TIC 8



## Recommended Input Fuse Selection

Drive Model E510	Fuse Type	
	Manufacturer: Bussmann / FERRAZ SHAWMUT	
	Model	Fuse Ampere Rating (A)
	200 V Class Single / Three-Phase Drives	
2P5-HXXX	Bussmann 20CT	690V 20A
201-HXXX	Bussmann 20CT	690V 20A
202-HXXX	Bussmann 35FE	690V 35A
203-HXXX	Bussmann 50FE	690V 50A
2P5-H3XX	Bussmann 20CT	690V 20A
201-H3XX	Bussmann 20CT	690V 20A
202-H3XX	Bussmann 20CT	690V 20A
203-H3XX	Bussmann 30FE	690V 30A
205-XXXX	Bussmann 50FE	690V 50A
208-XXXX	Bussmann 63FE	690V 63A
210-XXXX	FERRAZ SHAWMUT A50QS100-4	500V 100A
215-XXXX	Bussmann 120FEE / FERRAZ A50QS150-4	690V 120A / 500V 150A
220-XXXX	FERRAZ SHAWMUT A50QS150-4	500V 150A

Drive Model E510	Fuse Type	
	Manufacturer: Bussmann / FERRAZ SHAWMUT	
	Model	Fuse Ampere Rating (A)
	400 V Class Three-Phase Drives	
401-XXXX	Bussmann 10CT	690V 10A
402-XXXX	Bussmann 16CT	690V 16A
403-XXXX	Bussmann 16CT	690V 16A
405-XXXX	Bussmann 25ET	690V 25A
408-XXXX	Bussmann 40FE	690V 40A
410-XXXX	Bussmann 50FE	690V 50A
415-XXXX	Bussmann 63FE	690V 63A
420-XXXX	Bussmann 80FE	690V 80A
425-XXXX	FERRAZ SHAWMUT A50QS100-4	500V 100A

#### ◆ Motor Overtemperature Protection

Motor overtemperature protection shall be provided in the end use application.

#### ■ Field Wiring Terminals

All input and output field wiring terminals not located within the motor circuit shall be marked to indicate the proper connections that are to be made to each terminal and indicate that copper conductors, rated 75°C are to be used.

#### ■ Drive Short-Circuit Rating

This drive has undergone the UL short-circuit test, which certifies that during a short circuit in the power supply the current flow will not rise above value. Please see electrical ratings for maximum voltage and table below for current.

- The MCCB and breaker protection and fuse ratings (refer to the preceding table) shall be equal to or greater than the short-circuit tolerance of the power supply being used.
- Suitable for use on a circuit capable of delivering not more than ( A ) RMS symmetrical amperes for ( Hp ) Hp in 240 / 480 V class drives motor overload protection.

Horse Power ( Hp )	Current ( A )	Voltage ( V )
1 - 50	5,000	240 / 480

◆ **Drive Motor Overload Protection**

Set parameter 02-01 (motor rated current) to the appropriate value to enable motor overload protection. The internal motor overload protection is UL listed and in accordance with the NEC and CEC.

■ **02-01 Motor Rated Current**

Setting Range: Model Dependent  
 Factory Default: Model Dependent

The motor rated current parameter (02-01) protects the motor and allows for proper vector control when using open loop vector or flux vector control methods (00-00 = 1). The motor protection parameter 08-05 is set as factory default. Set 02-01 to the full load amps (FLA) stamped on the nameplate of the motor.

The operator must enter the rated current of the motor (02-01) in the menu during auto-tuning.

■ **Motor Overload Protection Selection**

The drive has an electronic overload protection function (OL1) based on time, output current, and output frequency, which protects the motor from overheating. The electronic thermal overload function is UL-recognized, so it does not require an external thermal overload relay for single motor operation.

This parameter selects the motor overload curve used according to the type of motor applied.

**Overload Protection Settings**

Setting	Description
08-05=0	Disabled
08-05=1	Enabled
08-12=0	Constant Torque (OL = 103 %) (150 % for 1 Minute)
08-12=1	Variable Torque (OL = 113 %)(123 % for 1 Minute)
08-11=0	Standard Motor protection
08-11=1	Inverter duty motor protection

Sets the motor overload protection function in 08 group according to the applicable motor.

Setting 08-05 = 0. Disables the motor overload protection function when two or more motors are connected to a single inverter. Use an alternative method to provide separate overload protection for each motor such as connecting a thermal overload relay to the power line of each motor.

Setting 08-12 = 0. To protect the general mechanical load, as long as the load is less than 103% rated current, the motor continue to run. The load is larger than 150% rated current, the motor will run for 1 minute. (Refer to following curve (1)).

Setting 08-12 = 1. To protect HVAC load(FANPUMP...so on)as long as the load is less than 113% rated current, the motor continue to run. The load is larger than 123% rated current, the motor will run for 1 minute.

Setting 08-11 = 0. For motors without a forced cooling fan (general purpose standard motor), the heat dissipation capability is lower when in low speed operation.

Setting 08-11 = 1. For motors with a forced cooling fan (inverter duty or V/F motor), the heat dissipation capability is not dependent upon the rotating speed.

To protect the motor from overload by using electronic overload protection, be sure to set parameter 02-01 according to the rated current value shown on the motor nameplate.

Refer to the following "Motor Overload Protection Time" for the standard motor overload protection curve example : Setting 08-12 = 0.

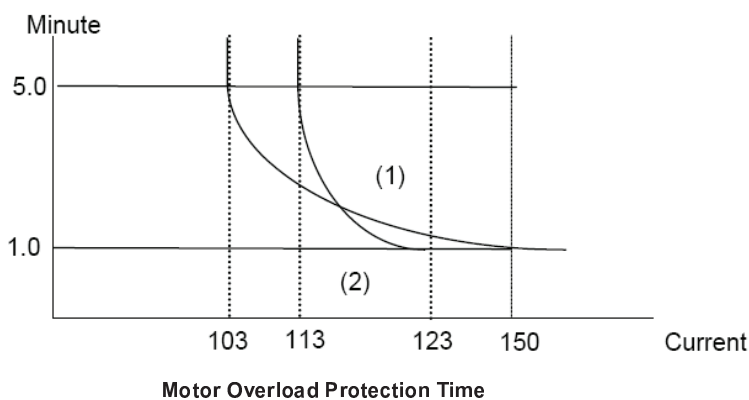

The heat sinking function will not be as effective when the motor run at low speed. So the thermal relay action level will decline at the same time. (The curve 1 will change to curve 2).

■ **08-06 Motor Overload Operation Selection**

Setting	Description
0	Coast-to-Stop After Overload Protection is Activated
1	Drive Will Not Trip when Overload Protection is Activated (OL1)

## Appendix 2: E510 parameter setting list

Customer				Inverter Model			
Site Location				Contact Phone			
Address							
Parameter code	Setting content	Parameter code	Setting content	Parameter code	Setting content	Parameter code	Setting content
00-00		02-08		04-03		05-27	
00-01		02-09		04-04		05-28	
00-02		02-10		04-05		05-29	
00-03		02-11		04-06		05-30	
00-04		02-12		04-07		05-31	
00-05		02-13		04-08		05-32	
00-06		02-14		04-09		05-33	
00-07		02-15		04-10		05-34	
00-08		02-16		04-11		05-35	
00-09		03-00		04-12		05-36	
00-10		03-01		04-13		05-37	
00-11		03-02		04-14		05-38	
00-12		03-03		04-15		05-39	
00-13		03-04		04-16		05-40	
00-14		03-05		05-00		05-41	
00-15		03-06		05-01		05-42	
00-16		03-07		05-02		05-43	
00-17		03-08		05-03		05-44	
00-18		03-09		05-04		05-45	
00-19		03-10		05-05		05-46	
00-20		03-11		05-06		05-47	
01-00		03-12		05-07		05-48	
01-01		03-13		05-08		06-00	
01-02		03-14		05-09		06-01	
01-03		03-15		05-10		06-02	
01-04		03-16		05-11		06-03	
01-05		03-17		05-12		06-04	
01-06		03-18		05-13		06-05	
01-07		03-19		05-14		06-06	
01-08		03-20		05-15		06-07	
01-09		03-21		05-16		06-08	
01-10		03-22		05-17		06-09	
01-11		03-23		05-18		06-10	
01-12		03-24		05-19		06-11	
02-00		03-25		05-20		06-12	
02-01		03-26		05-21		06-13	
02-02		03-27		05-22		06-14	
02-04		03-28		05-23		06-15	
02-05		04-00		05-24		06-16	
02-06		04-01		05-25		06-17	
02-07		04-02		05-26		06-18	

Parameter code	Setting content	Parameter code	Setting content	Parameter code	Setting content	Parameter code	Setting content
06-19		08-03		10-22		14-05	
06-20		08-04		11-00		14-06	
06-21		08-05		11-01		14-07	
06-22		08-06		11-02		14-08	
06-23		08-07		11-03		14-09	
06-24		08-08		11-04		14-10	
06-25		08-09		11-05		14-11	
06-26		08-10		11-06		14-12	
06-27		08-11		11-07		14-13	
06-28		08-12		11-08		14-14	
06-29		08-13		11-09		14-15	
06-30		08-14		11-11		14-16	
06-31		08-15		11-12		14-17	
06-32		08-16		11-13		14-18	
06-34		08-17		11-14		14-19	
06-35		08-18		11-15		14-20	
06-36		09-00		11-16		14-21	
06-37		09-01		11-17		14-22	
06-38		09-02		12-00		14-23	
06-39		09-03		12-01		14-24	
06-40		09-04		12-02		14-25	
06-41		09-05		12-03		14-26	
06-42		09-06		12-04		14-27	
06-43		09-07		12-05		14-28	
06-44		09-08		12-06		14-29	
06-45		09-09		12-07		14-30	
06-46		10-00		12-08		14-31	
06-47		10-01		12-09		14-32	
07-00		10-02		12-10		14-33	
07-01		10-03		12-11		14-34	
07-02		10-04		12-12		14-35	
07-03		10-05		12-13		14-36	
07-04		10-06		12-14		14-37	
07-05		10-07		12-15		14-38	
07-06		10-08		13-00		14-39	
07-07		10-09		13-01		14-40	
07-08		10-10		13-02		14-41	
07-09		10-11		13-03		14-42	
07-10		10-12		13-04		14-43	
07-11		10-13		13-05		14-44	
07-12		10-14		13-06		14-45	
07-13		10-15		13-07		14-46	
07-14		10-16		13-08		14-47	
07-15		10-17		14-00		15-00	
07-16		10-18		14-01		15-01	
08-00		10-19		14-02		15-02	
08-01		10-20		14-03		15-03	
08-02		10-21		14-04		15-04	

Parameter code	Setting content	Parameter code	Setting content	Parameter code	Setting content	Parameter code	Setting content
15-05		15-17		15-29			
15-06		15-18		15-30			
15-07		15-19		15-31			
15-08		15-20		15-32			
15-09		15-21					
15-10		15-22					
15-11		15-23					
15-12		15-24					
15-13		15-25					
15-14		15-26					
15-15		15-27					
15-16		15-28					

Information  
provided by  
**EMAG**  
Tel: 01902 601403  
[www.emag-ltd.co.uk](http://www.emag-ltd.co.uk)

# Appendix 3: E510 MODBUS Communication protocol

## 1. Communication Data Frame

E510 series inverter can be controlled by a PC or other controller with the Communication protocol, Modbus ASCII Mode & Mode RTU, RS485 or RS232. Frame length maximum 80 bytes.

### 1.1 Hardware installation

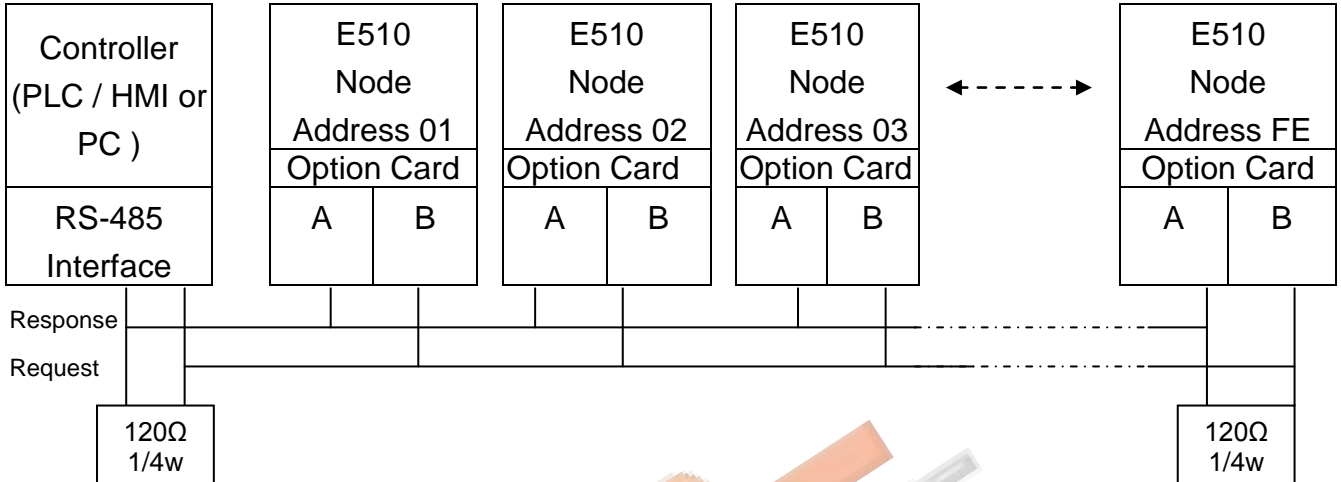

\*\* The network is terminated at each end with an external terminating resistor (120Ω, 1/4w)\*\*

### 1.2 Data format ASCII MODE

STX(3AH)	Start bit = 3AH
Address Hi	Communication Address(Station):
Address Lo	2-digit ASCII Code
Function Hi	Function Code (command):
Function Lo	2-digit ASCII Code
Command Start Address	command Start byte: 4-digit ASCII Code
Command Start Address	
Command Start Address	
Command Start Address	
Data length	The length of the command: 4-digit ASCII Code
Data length	
Data length	
Data length	
LRC Check Hi	LRC Check Code: 2-digit ASCII Code
LRC Check Lo	
END Hi	End Byte :
END Lo	



MASTER(PLC etc.) send request to SLAVE, whereas response to MASTER.

The signal receiving is illustrated here.

The data length is varied with the command(Function).

SLAVE Address
Function Code
DATA
CRC CHECK
Signal Interval

\*\* The interval should be maintained at 10ms between command signal and request.

### 1.3 Node (Address)

00H : Broadcast to all the drivers

01H : to the No.01 Drivers

0FH : to the No.15 Drivers

10H : to the No.16 Drivers

and so on...., Max to 32(20H)

### 1.4 Function Code

03H : Read the register contents

06H : write a WORD to register

08H : Loop test

10H : write several data to register(complex number register write)

## 2.CMS (Checksum and time-out definition)

### 2.1 LRC CHECK

ex: ADDRESS           01H  
 FUNCTION           03H  
 COMMAND            01H  
                       00H  
 DATA LENGTH       0AH

-----  
 0FH-----true complement

Checksum        =     F1H  
 CS(H)           =     46H (ASCII)  
 CS(L)           =     31H (ASCII)

**2.2 CRC CHECK:**CRC Check Code is calculated from SLAVE Address to end of the data. The

calculation method is illustrated as follow:

- (1). Load a 16-bit register with FFFF hex (all's1).Call this the CRC register.
- (2). Exclusive OR the first 8-bit byte of the message with the low-order byte of the 16-bit CRC register, putting the result in the CRC register.
- (3). Shift the CRC register one bit to the right (toward the LSB), Zero-filling the MSB, Extract and examines the LSB.

(4). (If the LSB was 0): Repeat Steps(3)(another shift). (If the LSB was 1): Exclusive OR the CRC register with the polynomial value A001 hex (1010 0000 0000 0001), putting the result in the CRC register.

(5). Repeat Steps (3) and (4) until 8 shifts been performed. When this is done, a complete 8-bit byteWill be processed .

(6). Repeat Steps (2) through (5) for next 8-bit byte of the message, Continue doing this until all bytes have been processed. The final content of the CRC register is the CRC value. Placing the CRC into the message: When the 16-bit CRC (2 8-bit bytes) is transmitted in the message, the Low-order byte will be transmitted first, followed by the high-order byte, For example, if the CRC value is 1241 hex, the CRC-16 Upper put the 41h, the CRC-16 Lower put the 12h.

- **CRC calculation application program**

```
UWORD ch_sum ( UBYTE long , UBYTE *rxdbuff )
{
    BYTE i = 0;
    UWORD wkg = 0xFFFF;
    while ( long-- )
    {
        wkg ^= rxdbuff++;
        for ( i = 0 ; i < 8; i++ )
        {
            if ( wkg & 0x0001 )
            {
                wkg = ( wkg >> 1 ) ^ 0xa001;
            }
            else
            {
                wkg = wkg >> 1;
            }
        }
    }
    return( wkg );
}
```

### 3. Error code

ASCII Mode

STX	‘.’
Address	‘0’
	‘1’
Function	‘8’
	‘6’
Exception code	‘5’
	‘1’
LRC Check	‘2’
	‘8’
END	‘CR’
	‘LF’

RTU Mode

SLAVE Address		02H
Function		83H
Exception code		52H
CRC-16	High	C0H
	Low	CDH

Under communication linking, the driver responses the Exception Code and send Function Code AND 80H to main system if there is error happened.

Error Code	Description
51	Function Code Error
52	Address Error
53	Data Amount Error
54	DATA Over Range
55	Writing Mode Error

## 4 Inverter Control

### 4.1 Command Data (Readable and Writable)

Register No.	Bit	Content
2500H	Reserved	
2501H	Operation Signal	
	0	Operation Command    1 : Run    0 : Stop
	1	Reverse Command    1 : Reverse    0 : Forward
	2	Abnormal    1 : EFO
	3	Fault Reset    1 : Reset
	4	Jog Forward Command    1 : Jog Forward
	5	Jog Reverse Command    1 : Jog Reverse
	6	Multi-function CommandS1    1 : "ON"    0 : "OFF"
	7	Multi-function CommandS2    1 : "ON"    0 : "OFF"
	8	Multi-function CommandS3    1 : "ON"    0 : "OFF"
	9	Multi-function CommandS4    1 : "ON"    0 : "OFF"
	A	Multi-function CommandS5    1 : "ON"    0 : "OFF"
	B	Multi-function CommandS6    1 : "ON"    0 : "OFF"
	C	Relay R1    1 : "ON"    0 : "OFF"
D	Relay R2    1 : "ON"    0 : "OFF"	
	E~F	Reserved
2502H	Frequency Command	
2503~251FH	Reserved	

Note: Write in zero for Not used BIT, do not write in data for the reserved register.

### 4.2 Monitor Data (Only for reading)

Register No.	Bit	Content
2520H	State Signal	
	0	Operation state    1 : Run    0 : Stop
	1	Direction state    1 : Reverse    0 : Forward
	2	Inverter operation prepare state    1:ready    0 : unready
	3	Abnormal    1 : Abnormal
	4	DATA setting error    1 : Error
		5-F

Register No.	Content		
2521H	<b>abnormity</b>		
	00	The inverter is normal	20 Over current during decelerating)( OC-D )
	01	Inverter over heat)( OH )	21 (OC_S)
	02	Over current at stop)( OC )	22 Reserved
	03	Under voltage( LV )	23 Under voltage during running( LV-C )
	04	Over voltage)( OV )	24 Over voltage at constant speed( OV-C )
	05	Reserved	25 Inverter over heat during running( OH-C )
	06	External BB( bb )	26 stop at 0 Hz( STP0 )
	07	( CTER )	27 Direct start disable)( STP1 )
	08	( PDER )	28 Control panel emergency stop( STP2 )
	09	(EPR)	29 Keypad operation error)( Err1 )
	10	(ATER)	30 Parameter setting error( Err2 )
	11	( OL3 )	31 (Err4)
	12	Inverter over load( OL2 )	32 Communication failure) ( Err5 )
	13	Motor load(OL1)	33 Communication failure( Err6 )
	14	(EFO)	34 ( Err7 )
	15	External bb E.S )	35 (Err8)
	16	( LOC )	36 Reserved
	17	Reserved	37 Reserved
	18	Over voltage at constant speed ( OC-C )	38 (EPR1)
	19	Over current during accelerating)( OC-A )	39 (EPR2)
40	Inverter over speed( OVSP )		
2522H	<b>Sequence input status</b>		
	0	Terminal S1	1 :“ON” 0:“OFF”
	1	Terminal S2	1 :“ON” 0:“OFF”
	2	Terminal S3	1 :“ON” 0:“OFF”
	3	Terminal S4	1 :“ON” 0:“OFF”
	4	Terminal S5	1 :“ON” 0:“OFF”
	5	Terminal S6	1 :“ON” 0:“OFF”
	<b>Contact output</b>		
	6	Relay R1	1 :“ON” 0:“OFF”
	7	Relay R2	1 :“ON” 0:“OFF”
	9~F	Reserved	

Register No.	Content
2523H	frequency command(100/1Hz)
2524H	Output frequency (100/1Hz)
2525H	Output voltage command (10/1V)
2526H	DC voltage command (1/1V)
2527H	Output current (10/1A)
2528H	Temperature
2529H	Output torque
252AH	PID feedback (100% / fmax , 10/1% )
252BH	PID input (100% / fmax, 10/1%)
252CH	TM2 AVI input value (1000 / 10V) *1
252DH	TM2 ACI input value (1000 / 10V) *1
252EH--252FH	reserved

Information  
provided by  
**EMAG**  
Tel: 01902 601403  
[www.emag-ltd.co.uk](http://www.emag-ltd.co.uk)



#### 4.3 Read the data in the holding register [03H]

Master unit reads the contents of the holding register with the continuous number for the specified quantity.

- Note: 1. Limit number of read data, RTU: 37, ASCII: 17.  
 2. Can only Continuous read the address of the same Group  
 3. Read data Quantity ≥ 1.

(Example) Read the SLAVE station No: 01, E510 drive's frequency command.

#### ASCII Mode

Instruction Message		Response Message (Normal)		Response (Fault)	
3AH	STX	3AH	STX	3AH	STX
30H	Node Address	30H	Node Address	30H	Node Address
31H		31H		31H	
30H	Function Code	30H	Function Code	38H	Function Code
33H		33H		33H	
41H	Start Address	30H	DATA Number	35H	Error Code
30H		32H		32H	
32H		31H	First holding register	?	LRC CHECK
33H		37H		?	
30H	Quantity	37H	LRC CHECK	0DH	END
30H		30H		0AH	
30H		?			
31H		?			
?	LRC CHECK	0DH	END		
?		0AH			
0DH	END				
0AH					

#### RTU Mode

Instruction Message			Response Message (Normal)			Response (Fault)		
Node Address		01H	Node Address		01H	Node Address		01H
Function Code		03H	Function Code		03H	Function Code		83H
Start Address	High	A0H	DATA Number		02H	Error Code		52H
	Low	23H	First holding register	High	07H	CRC-16	High	C0H
Quantity	High	00H		Low	D0H		Low	CDH
	CRC-16	High	57H	CRC-16	High	BBH		
Low		C0H	Low		E8H			

#### 4.4 LOOP BACK testing [08H]

The function code checks communication between MASTER and SLAVE.

The instruction message is returned as a response message without being changed.

Any value can be used for test codes or data.

#### ASCII Mode

Instruction Message		Response Message (Normal)		Response(Fault)	
3AH	STX	3AH	STX	3AH	STX
30H	Node Address	30H	Node Address	30H	Node Address
31H		31H		31H	
30H	Function Code	30H	Function Code	38H	Function Code
38H		38H		38H	
30H	Test Code	30H	Test Code	32H	Error Code
30H		30H		30H	
30H		30H		37H	LRC CHEC
30H		30H		35H	
41H	DATA	41H	DATA	0DH	END
35H		35H		0AH	
33H		33H			
37H		37H			
31H	LRC CHECK	31H	LRC CHECK		
42H		42H			
0DH	END	0DH	END		
0AH		0AH			

#### RTU Mode

Instruction Message			Response Message (Normal)			Response(Fault)		
Node Address		01H	Node Address		01H	Node Address		01H
Function Code		08H	Function Code		08H	Function Code		88H
Test Code	High	00H	Test Code	High	00H	Error Code		20H
	Low	00H		Test Code	Low	00H	CRC-16	High
DATA	High	A5H	DATA		High	A5H		CRC-16
	Low	37H		DATA	Low	37H		
CRC-16	High	DAH	CRC-16		High	DAH		
	Low	8DH		CRC-16	Low	8DH		

#### 4.5 Write holding register [06H]

Specified data are written into the several specified holding registers from the Specified respectively.

(Example)Set SLAVE station No:01, writeE510 drive frequency reference 60.0HZ.

#### ASCII Mode

Instruction Message		Response Message (Normal)		Response (Fault)	
3AH	STX	3AH	STX	3AH	STX
30H	Node Address	30H	Node Address	30H	Node Address
31H		31H		31H	
30H	Function Code	30H	Function Code	38H	Function Code
36H		36H		36H	
41H	Start Address	41H	Start Address	35H	Error Code
30H		30H		32H	
30H		30H		?	LRC CHECK
32H		32H		?	
31H	DATA	31H	DATA	0DH	END
37H		37H		0AH	
37H		37H			
30H		30H			
?		LRC CHECK		?	LRC CHECK
?	?				
0DH	END	0DH	END		
0AH		0AH			

#### RTU Mode

Instruction Message			Response Message (Normal)			Response (Fault)		
Node Address		01H	Node Address		01H	Node Address		01H
Function Code		06H	Function Code		06H	Function Code		86H
Start Address	High	A0H	Start Address	High	A0H	Error Code		52H
	Low	02H		DATA	Low	02H	CRC-16	High
DATA	High	17H	DATA		High	17H		CRC-16
	Low	70H		CRC-16	Low	70H		
CRC-16	High	04H	CRC-16		High	04H		
	Low	1EH		CRC-16	Low	1EH		

#### 4.6 Write in several holding registers [10H]

Specified data are written into the several specified holding registers from the Specified number, respectively.

- Note: 1. Limit number of read data, RTU: 35, ASCII:15.  
 2. Can only Continuous read the address of the same Group.  
 3. Read data Quantity≥1.

(Example)Set SLAVE station No:01, E510 drive as forward run at frequency reference 60.0HZ.

#### ASCII Mode

Instruction Message		Response Message (Normal)		Response(Fault)	
3AH	STX	3AH	STX	3AH	STX
30H	Node Address	30H	Node Address	30H	Node Address
31H		31H		31H	
31H	Function Code	31H	Function Code	39H	Function Code
30H		30H		30H	
41H	Start Address	41H	Start Address	35H	Error Code
30H		30H		32H	
30H		30H		?	LRC CHECK
31H		31H		?	
30H	Quantity	30H	Quantity	0DH	END
30H		30H		0AH	
30H		30H			
32H		32H			
30H	DATA Number *	?	LRC CHECK		
34H		?			
30H	First DATA	0DH	END		
30H		0AH			
30H					
31H					
31H	Next DATA				
37H					
37H					
30H					
?	LRC CHECK				
?					
0DH	END				
0AH					

### RTU Mode

#### Instruction Message

Node Address		01H
Function Code		10H
Start Address	High	A0H
	Low	01H
Quantity	High	00H
	Low	02H
DATA Number *		04H
First DATA	High	00H
	Low	01H
Next DATA	High	17H
	Low	70H
CRC-16	High	95H
	Low	B0H

#### Response Message (Normal)

Node Address		01H
Function Code		10H
Start Address	High	A0H
	Low	01H
Quantity	High	00H
	Low	02H
CRC-16	High	32H
	Low	08H

#### Response(Fault)

Node Address		01H
Function Code		90H
Error Code		52H
CRC-16	High	CDH
	Low	FDH

\* DATA Numbers are the actual number timers 2

Information provided by  
**EMAG**  
 Tel: 01902 601403  
 www.emag-ltd.co.uk

## 5. Comparison list between parameter and register

Note:

Parameter register No.: GGnnH, "GG" means Group number , "nn" means Parameter number

for example: the address of Pr 08-03 is 0803H. the address of Pr 10-11 is 0A0BH

Register No.	Function	Register No.	Function	Register No.	Function
<b>Group00</b>		<b>Group01</b>		<b>Group02</b>	
0000H	00-00	0100H	01-00	0200H	02-00
0001H	00-01	0101H	01-01	0201H	02-01
0002H	00-02	0102H	01-02	0202H	02-02
0003H	00-03	0103H	01-03	0203H	02-03
0004H	00-04	0104H	01-04	0204H	02-04
0005H	00-05	0105H	01-05	0205H	02-05
0006H	00-06	0106H	01-06	0206H	02-06
0007H	00-07	0107H	01-07	0207H	02-07
0008H	00-08	0108H	01-08	Reserved	02-08
0009H	00-09	0109H	01-09	Reserved	02-09
000AH	00-10	010AH	01-10	Reserved	02-10
000BH	00-11	010BH	01-11	Reserved	02-11
000CH	00-12	010CH	01-12	Reserved	02-12
000DH	00-13			Reserved	02-13
000EH	00-14			020DH	02-14
000FH	00-15			020EH	02-15
0010H	00-16			0210H	02-16
0011H	00-17				
0012H	00-18				
0013H	00-19				
0014H	00-20				



Register No.	Function	Register No.	Function	Register No.	Function
<b>Group03</b>		<b>Group04</b>		<b>Group05</b>	
0300H	03-00	0400H	04-00	0500H	05-00
0301H	03-01	0401H	04-01	0501H	05-01
0302H	03-02	0402H	04-02	0502H	05-02
0303H	03-03	0403H	04-03	0503H	05-03
0304H	03-04	0404H	04-04	0504H	05-04
0305H	03-05	0405H	04-05	0505H	05-05
0306H	03-06	0406H	04-06	0506H	05-06
0307H	03-07	0407H	04-07	0507H	05-07
0308H	03-08	0408H	04-08	0508H	05-08
0309H	03-09	0409H	04-09	0509H	05-09
030AH	03-10	040AH	04-10	050AH	05-10
030BH	03-11	040BH	04-11	050BH	05-11
030CH	03-12	040CH	04-12	050CH	05-12
030DH	03-13	040DH	04-13	050DH	05-13
030EH	03-14	040EH	04-14	050EH	05-14
030FH	03-15	040FH	04-15	050FH	05-15
0310H	03-16			0510H	05-16
0311H	03-17			0511H	05-17
0312H	03-18			0512H	05-18
0313H	03-19			0513H	05-19
0314H	03-20			0514H	05-20
0315H	03-21			0515H	05-21
0316H	03-22			0516H	05-22
0317H	03-23			0517H	05-23
0318H	03-24			0518H	05-24
0319H	03-25			0519H	05-25
031AH	03-26			051AH	05-26
				051BH	05-27
				051CH	05-28
				051DH	05-29
				051EH	05-30
				051FH	05-31
				0520H	05-32
				0521H	05-33
				0522H	05-34
				0523H	05-35
				0524H	05-36

Register No.	Function	Register No.	Function	Register No.	Function
<b>Group03</b>		<b>Group04</b>		<b>Group05</b>	
				0525H	05-37
				0526H	05-38
				0527H	05-39
				0528H	05-40
				0529H	05-41
				052AH	05-42
				052BH	05-43
				052CH	05-44
				052DH	05-45
				052EH	05-46
				052FH	05-47
				0530H	05-48

Register No.	Function	Register No.	Function	Register No.	Function
<b>Group06</b>		<b>Group07</b>		<b>Group08</b>	
0600H	06-00	0700H	07-00	0800H	08-00
0601H	06-01	0701H	07-01	0801H	08-01
0602H	06-02	0702H	07-02	0802H	08-02
0603H	06-03	0703H	07-03	0803H	08-03
0604H	06-04	0704H	07-04	0804H	08-04
0605H	06-05	0705H	07-05	0805H	08-05
0606H	06-06	0706H	07-06	0806H	08-06
0607H	06-07	0707H	07-07	0807H	08-07
0608H	06-08	0708H	07-08	0808H	08-08
0609H	06-09	0709H	07-09	0809H	08-09
060AH	06-10	070AH	07-10	080AH	08-10
060BH	06-11	070BH	07-11	080BH	08-11
060CH	06-12	070CH	07-12	080CH	08-12
060DH	06-13	070DH	07-13	080DH	08-13
060EH	06-14	070EH	07-14	080EH	08-14
060FH	06-15			080FH	08-15
0610H	06-16			0810H	08-16
0611H	06-17			0811H	08-17
0612H	06-18			0812H	08-18
0613H	06-19				
0614H	06-20				

Register No.	Function	Register No.	Function	Register No.	Function
<b>Group06</b>		<b>Group07</b>		<b>Group08</b>	
0615H	06-21				
0616H	06-22				
0617H	06-23				
0618H	06-24				
0619H	06-25				
061AH	06-26				
061BH	06-27				
061CH	06-28				
061DH	06-29				
061EH	06-30				
061FH	06-31				
0620H	06-32				
0621H	06-33				
0622H	06-34				
0623H	06-35				
0624H	06-36				
0625H	06-37				
0626H	06-38				
0627H	06-39				
0628H	06-40				
0629H	06-41				
062AH	06-42				
062BH	06-43				
062CH	06-44				
062DH	06-45				
062EH	06-46				
062FH	06-47				

Information provided by  
  
 Tel: 01902 601403  
 www.emag-ltd.co.uk

Register No.	Function	Register No.	Function	Register No.	Function
<b>Group09</b>		<b>Group10</b>		<b>Group11</b>	
0900H	09-00	0A00H	10-00	0B00H	11-00
0901H	09-01	0A01H	10-01	0B01H	11-01
0902H	09-02	0A02H	10-02	0B02H	11-02
0903H	09-03	0A03H	10-03	0B03H	11-03
0904H	09-04	0A04H	10-04	0B04H	11-04
0905H	09-05	0A05H	10-05	0B05H	11-05
0906H	09-06	0A06H	10-06	0B06H	11-06
0907H	09-07	0A07H	10-07	0B07H	11-07
0908H	09-08	0A08H	10-08	0B08H	11-08
0909H	09-09	0A09H	10-09	0B09H	11-09
		0A0AH	10-10	0B0AH	11-10
		0A0BH	10-11	0B0BH	11-11
		0A0CH	10-12	0B0CH	11-12
		0A0DH	10-13	0B0DH	11-13
		0A0EH	10-14	0B0EH	11-14
		0A0FH	10-15	0B0FH	11-15
		0A10H	10-16	0B10H	11-16
		0A11H	10-17	0B11H	11-17
		0A12H	10-18		
		0A13H	10-19		
		0A14H	10-20		
		0A15H	10-21		
		0A16H	10-22		

Register No.	Function	Register No.	Function	Register No.	Function
<b>Group12</b>		<b>Group13</b>		<b>Group15 *Note</b>	
0C00H	12-00	0D00H	13-00	0E20H	15-32
0C01H	12-01	0D01H	13-01		
0C02H	12-02	0D02H	13-02		
0C03H	12-03	0D03H	13-03		
0C04H	12-04	0D04H	13-04		
0C05H	12-05	0D05H	13-05		
0C06H	12-06	0D06H	13-06		
0C07H	12-07	0D07H	13-07		
0C08H	12-08	0D08H	13-08		
0C09H	12-09				
0C0AH	12-10				
0C0BH	12-11				
0C0CH	12-12				
0C0DH	12-13				
0C0EH	12-14				
0C0FH	12-15				

\*Note: The communication address of Group 14~15 can be found in "E510 PLC communication protocol", except 15-32.

Information provided by  
**EMAG**  
 Tel: 01902 601400  
 www.emag-ltd.co.uk

# Appendix4: PLC Communication Protocol

## E510 PLC MEMORY MAP

Ladder Code(0-20 Line)	A000h~A031h	50words
Ladder Code(21-40 Line)	A032h~A063h	50words
Ladder Code(41-60 Line)	A064h~A095h	50words
Ladder Code(61-80 Line)	A096h~A0C7h	50words
Timer Code	A200h~A227h	40words
Counter Code	A228h~A247h	32words
Analog Code	A248h~A25Fh	24words
Operation control instruction	A260h~A28Fh	48words
Add Subtract code	A290h~A2A3h	20words
Multiple Division code	A2A4h~A2B7h	20words
Timer mode7 Set Value data type selection	A2B8h	1word

The final output detection(judgement for ladder)

Reserved	A400h
Reserved	
Input Bit (S1~S6)	A401h
Reserved	
Timer Bit (T1~T8)	A402h
Reserved	
Counter Bit (C1~C8)	A403h
Reserved	
Auxiliary relay (M1~M8)	A404h
Auxiliary relay (M9~M15)	
Operation control (F1~F8)	A405h
Reserved	
Analog Bit (G1~G8)	A406h
Encoder bit (H1~H4)	
Output Bit (Q1~Q2)	A407h
Reserved	
Compile machine Code	A408h~A457h

Note:

Bit7	Bit6	Bit5	Bit4	Bit3	Bit2	Bit1	Bit0
8	7	6	5	4	3	2	1



Trigger detection (judgement forFunction)

Encoder Bit	A458h
Analog Bit	
Timer Bit (Current state)	A459h
Timer Bit (Last state)	
Counter Bit (Current state)	A45Ah
Counter Bit (Last state)	
Operation Control Bit	A45Bh
AS Bit	
MD Bit	A45Ch

**PLC Operation instruction**

RUN&STOP	A600h
Clear all memory	A601h

Cipher Address	170Ah
----------------	-------

**Ladder Component Arrangement mode**

**X1---X12 : Contact Component**

**Y1---Y4 : Coil Component**

**V1---V12 : Vertical line**

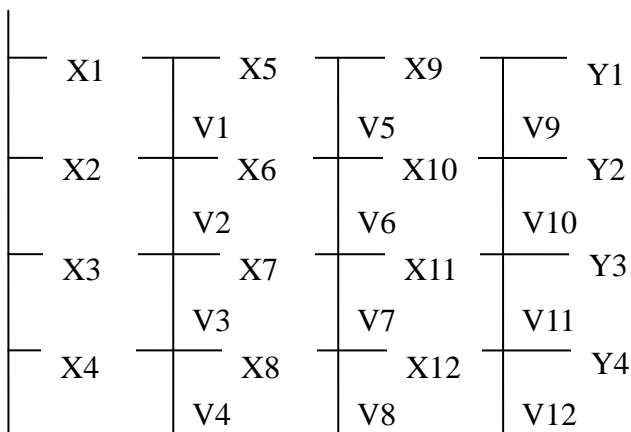

## Code in the EEPROM/RAM Arrangement

### A. Ladder Part ( Note: L =Low byte , H = High byte )

Page	Address	Location	Code								
			H	C3	C2	C1	C0	N3	N2	N1	N0
1	A000h	X1	H	C3	C2	C1	C0	N3	N2	N1	N0
		X2	L	C3	C2	C1	C0	N3	N2	N1	N0
	A001h	X3	H	C3	C2	C1	C0	N3	N2	N1	N0
		X4	L	C3	C2	C1	C0	N3	N2	N1	N0
	A002h	X5	H	C3	C2	C1	C0	N3	N2	N1	N0
		X6	L	C3	C2	C1	C0	N3	N2	N1	N0
	A003h	X7	H	C3	C2	C1	C0	N3	N2	N1	N0
		X8	L	C3	C2	C1	C0	N3	N2	N1	N0
	A004h	X9	H	C3	C2	C1	C0	N3	N2	N1	N0
		X10	L	C3	C2	C1	C0	N3	N2	N1	N0
	A005h	X11	H	C3	C2	C1	C0	N3	N2	N1	N0
		X12	L	C3	C2	C1	C0	N3	N2	N1	N0
	A006h	Y1	H	C3	C2	C1	C0	N3	N2	N1	N0
		Y2	L	C3	C2	C1	C0	N3	N2	N1	N0
	A007h	Y3	H	C3	C2	C1	C0	N3	N2	N1	N0
		Y4	L	C3	C2	C1	C0	N3	N2	N1	N0
	A008h	V1~V4	H	V4	V3	V2	V1	0	0	0	0
		V5~V8	L	V8	V7	V6	V5	0	0	0	0
	A009h	V9~V12	H	V12	V11	V10	V9	0	0	0	0
		Reserved	L	0	0	0	0	0	0	0	0

Page	Address	Location
2	A00Ah	X1
		X2
	A00Bh	X3
		X4
	A00Ch	X5
		X6
	A00Dh	X7
		X8
	A00Eh	X9
		X10
	A00Fh	X11
		X12
	A010h	Y1
		Y2
	A011h	Y3
		Y4
	A012h	V1~V4
		V5~V8
A013h	V9~V12	
	Reserved	

Page	Address	Location
3	A014h	X1
		X2
	A015h	X3
		X4
	A016h	X5
		X6
	A017h	X7
		X8
	A018h	X9
		X10
	A019h	X11
		X12
	A01Ah	Y1
		Y2
	A01Bh	Y3
		Y4
	A01Ch	V1~V4
		V5~V8
A01Dh	V9~V12	
	Reserved	

Page	Address	Location
4	A01Eh	X1
		X2
	A01Fh	X3
		X4
	A020h	X5
		X6
	A021h	X7
		X8
	A022h	X9
		X10
	A023h	X11
		X12
	A024h	Y1
		Y2
	A025h	Y3
		Y4
	A026h	V1~V4
		V5~V8
A027h	V9~V12	
	Reserved	

Page	Address	Location
5	A028h	X1
		X2
	A029h	X3
		X4
	A02Ah	X5
		X6
	A02Bh	X7
		X8
	A02Ch	X9
		X10
	A02Dh	X11
		X12
	A02Eh	Y1
		Y2
	A02Fh	Y3
		Y4
	A030h	V1~V4
		V5~V8
A031h	V9~V12	
	Reserved	

Page	Address	Location	Code								
6	A032h	X1	( Byte )	C3	C2	C1	C0	N3	N2	N1	N0
		X2	( Byte )	C3	C2	C1	C0	N3	N2	N1	N0
	A033h	X3	( Byte )	C3	C2	C1	C0	N3	N2	N1	N0
		X4	( Byte )	C3	C2	C1	C0	N3	N2	N1	N0
	A034h	X5	( Byte )	C3	C2	C1	C0	N3	N2	N1	N0
		X6	( Byte )	C3	C2	C1	C0	N3	N2	N1	N0
	A035h	X7	( Byte )	C3	C2	C1	C0	N3	N2	N1	N0
		X8	( Byte )	C3	C2	C1	C0	N3	N2	N1	N0
	A036h	X9	( Byte )	C3	C2	C1	C0	N3	N2	N1	N0
		X10	( Byte )	C3	C2	C1	C0	N3	N2	N1	N0
	A037h	X11	( Byte )	C3	C2	C1	C0	N3	N2	N1	N0
		X12	( Byte )	C3	C2	C1	C0	N3	N2	N1	N0
	A038h	Y1	( Byte )	C3	C2	C1	C0	N3	N2	N1	N0
		Y2	( Byte )	C3	C2	C1	C0	N3	N2	N1	N0
	A039h	Y3	( Byte )	C3	C2	C1	C0	N3	N2	N1	N0
		Y4	( Byte )	C3	C2	C1	C0	N3	N2	N1	N0
	A03Ah	V1~ V4		V4	V3	V2	V1	0	0	0	0
		V5~ V8		V8	V7	V6	V5	0	0	0	0
	A03Bh	V9~V12		V12	V11	V10	V9	0	0	0	0
		Reserved		0	0	0	0	0	0	0	0

Page	Address	Location
7	A03Ch	X1
		X2
	A03Dh	X3
		X4
	A03Eh	X5
		X6
	A03Fh	X7
		X8
	A040h	X9
		X10
	A041h	X11
		X12
	A042h	Y1
		Y2
	A043h	Y3
		Y4
	A044h	V1~V4
		V5~V8
	A045h	V9~V12
		Reserved

Page	Address	Location
8	A046h	X1
		X2
	A047h	X3
		X4
	A048h	X5
		X6
	A049h	X7
		X8
	A04Ah	X9
		X10
	A04Bh	X11
		X12
	A04Ch	Y1
		Y2
	A04Dh	Y3
		Y4
	A04Eh	V1~V4
		V5~V8
	A04Fh	V9~V12
		Reserved

Page	Address	Location
9	A050h	X1
		X2
	A051h	X3
		X4
	A052h	X5
		X6
	A053h	X7
		X8
	A054h	X9
		X10
	A055h	X11
		X12
	A056h	Y1
		Y2
	A057h	Y3
		Y4
	A058h	V1~V4
		V5~V8
	A059h	V9~V12
		Reserved

Page	Address	Location
10	A05Ah	X1
		X2
	A05Bh	X3
		X4
	A05Ch	X5
		X6
	A05Dh	X7
		X8
	A05Eh	X9
		X10
	A05Fh	X11
		X12
	A060h	Y1
		Y2
	A061h	Y3
		Y4
	A062h	V1~V4
		V5~V8
	A063h	V9~V12
		Reserved

Page	Start address	Length (word)
10	A064	10
11	A06E	10
12	A078	10
13	A082	10
14	A08C	10
15	A096	10
16	A0A0	10
17	A0AA	10
18	A0B4	10
19	A0BE	10
20	A0C8	10

Information  
provided by  
**EMAG**  
Tel: 01902 601403  
[www.emag-ltd.co.uk](http://www.emag-ltd.co.uk)



## B. FUNCTION BLOCK

### 1. Timer (10Byte)----- A200h~A227h(8groups)

Mode7 Set value data types Flag P2

A2B8h	0	0	0	0	0	0	0	0	0	T8	T7	T6	T5	T4	T3	T2	T1
-------	---	---	---	---	---	---	---	---	---	----	----	----	----	----	----	----	----

Timer1	A200h~A204h	Timer5	A214h~A218h
Timer2	A205h~A209h	Timer6	A219h~A21Dh
Timer3	A20Ah~A20Eh	Timer7	A21Eh~A222h
Timer4	A20Fh~A213h	Timer8	A223h~A227h

### 2. Counter (8Byte)----- A228h~A247h(8groups)

Counter1	A228h~A22Bh	Counter5	A238h~A23Bh
Counter2	A22Ch~A22Fh	Counter6	A23Ch~A23Fh
Counter3	A230h~A233h	Counter7	A240h~A243h
Counter4	A234h~A237h	Counter8	A244h~A247h

### 3. Analog Compare (6Byte)----- A248h~A25Fh(8groups)

Analog1	A248h~A24Ah	Analog5	A254h~A256h
Analog2	A24Bh~A24Dh	Analog6	A257h~A259h
Analog3	A24Eh~A250h	Analog7	A25Ah~A25Ch
Analog4	A251h~A253h	Analog8	A25Dh~A25Fh

**4. Operation Control Instruction (12Byte)----- A260h~A28Fh(8groups)**

Control1	A260h~A265h		Control5	A278h~A27Dh
Control2	A266h~A26Bh		Control6	A27Eh~A283h
Control3	A26Ch~A271h		Control7	A284h~A289h
Control4	A272h~A277h		Control8	A28Ah~A28Fh

**5. Add-Subtract (10bytes) -----A290h~A2A3h(4groups)**

Add-Subtract1	A290h~A294h
Add-Subtract2	A295h~A299h
Add-Subtract3	A29Ah~A29Eh
Add-Subtract4	A29Fh~A2A3h

**6. Multiply-Divide (10bytes) A2A4h~A2B7h (4groups)**

Multiply-Divide1	A2A4h~A2A8h
Multiply-Divide2	A2A9h~A2ADh
Multiply-Divide3	A2AEh~A2B2h
Multiply-Divide4	A2B3h~A2B7h

## 7. PLC RUN→A600h~ CLEAR MEMORY→A601h

RUN&STOP-----	X	X	X	X	X	X	X
CLEAR PLC MEMORY--	X	X	X	X	X	X	RS
	X	X	X	X	X	X	X
	X	X	X	X	X	X	C

### RS : PLC Operation instruction(Bit 0)

0: PLC stop  
1: PLC Run

### C : PLC ALL MEMORY CLEAR(Bit 0)

0: Disable  
1: Enable

Information  
provided by  
**EMAG**  
Tel: 01902 601403  
[www.emag-ltd.co.uk](http://www.emag-ltd.co.uk)

# Appendix 5: JN5-CM-USB instruction manual

## 1. Model number and specification

### 1.1 Model number and function instruction

JN5-CM-USB is a RS232 USB type converted to RS485 communication format. It is used for communication control between PC and inverter.

### 1.2 Dimensions of JN5-CM-USB

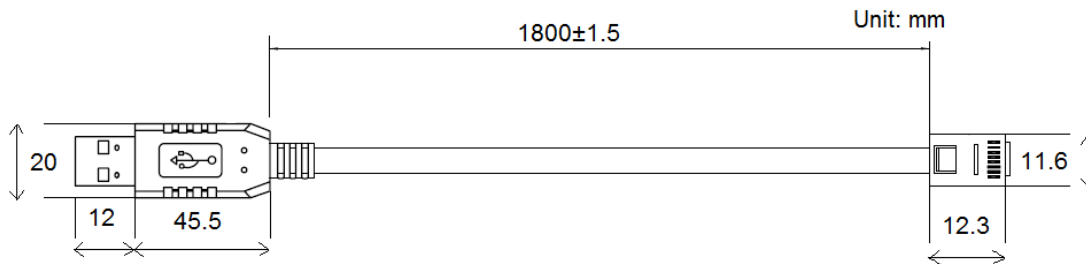

### 1.3 Connection between inverter and computer.

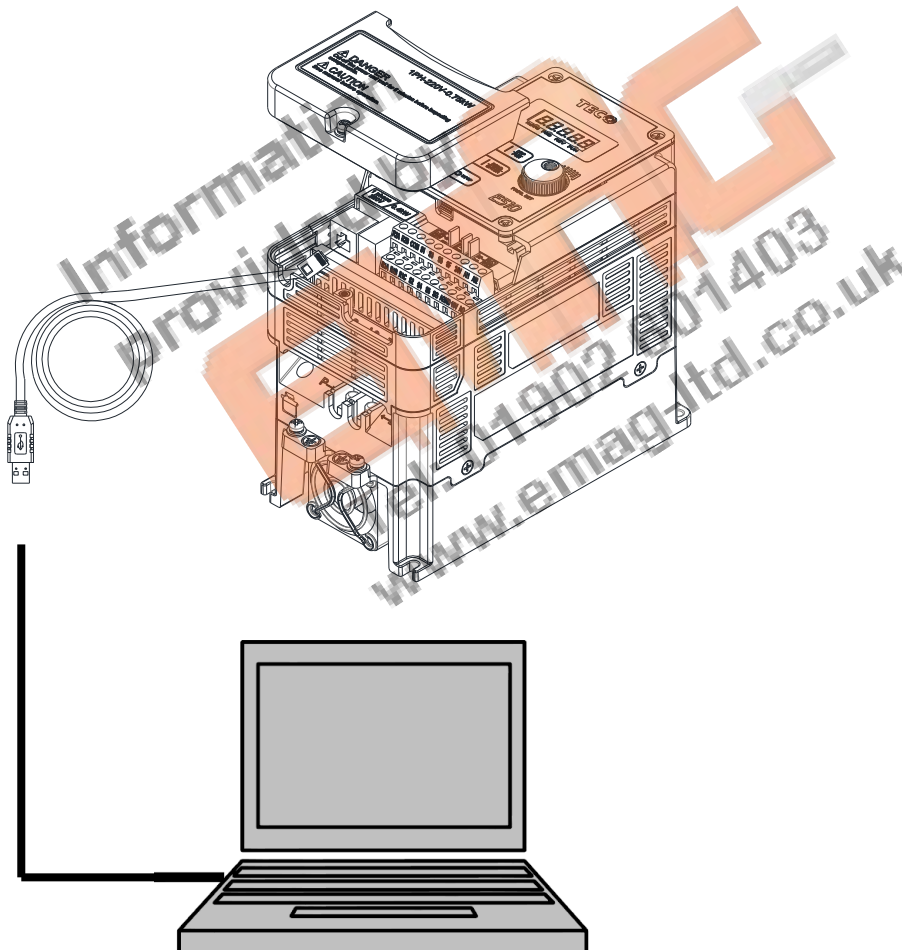

## 2. USB Interface Cable Pin Definition

### 2.1 RS232/USB at PC side.

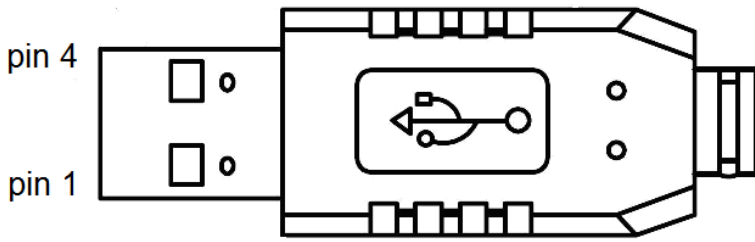

RS485/RJ45 connector at inverter side.

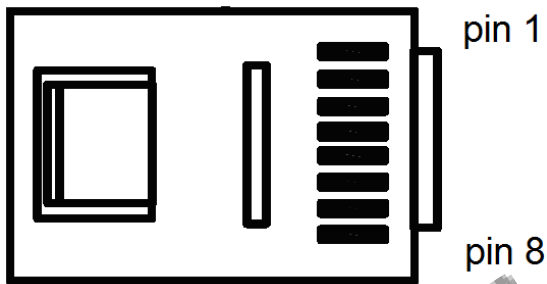

### 2.2 RS485/RJ45 Pin Definition.

Pin No.	Pin 1	Pin 2	Pin 3	Pin 4	Pin 5	Pin 6	Pin 7	Pin 8
Define	A	B	NC	NC	NC	NC	VCC	GND

Note:

1. A/B phase signal (Pin1&Pin2) is differential mode data signal of RS485.
2. VCC&GND is the +5Vdc power supply provided by inverter internal power source.

## 3. Notice

- 3-1. Please turn off the power before you connect the cable..
- 3-2. Once inverter is powered off during communication. PC software will show “communication error”.
- 3-3. If there is any error during communication, please check the wiring connection and restart the pc software.

## Appendix 6: 510 series accessories manual

Accessories	Model	Function	Notes
Keypad Extension cable	JN5-CB-01M	Keypad extension cable for 510 series	1m
	JN5-CB-02M		2m
	JN5-CB-03M		3m
	JN5-CB-05M		5m
NEMA Kits	JN5-NK-E01	Mechanical device consisting of anti-dust cover on the upper part and wiring box on the bottom to meet NEMA 1	Only for frame1
	JN5-NK-E02		Only for frame2
	JN5-NK-E03		Only for frame3
	JN5-NK-E04		Only for frame4
Copy module	JN5-CU	<ul style="list-style-type: none"> <li>① Duplicating parameters setting from one inverter to another inverter</li> <li>② As a remote keypad to be used</li> <li>③ Using RJ45 line to connect inverter</li> </ul>	
Communication modules	JN5-CM-PDP	For connection of Profibus-DP communication protocol	For 510 series
	JN5-CM-TCP-IP	For connection of TCP-IP communication protocol	
	JN5-CM-DNET	For connection of DeviceNet communication protocol	
	JN5-CM-CAN	For connection of CANopen communication protocol	
RJ45 to USB connection cable	JN5-CM-USB	Using the TECO exclusive PC-software line	1.8m
	JN6-CM-USB-3		3m